

Reference Diode

General Description

The LM136-2.5/LM236-2.5 and LM336-2.5 integrated circuits are precision 2.5V shunt regulator diodes. These monolithic IC voltage references operate as a low-temperature-coefficient 2.5V zener with 0.2Ω dynamic impedance. A third terminal on the LM136-2.5 allows the reference voltage and temperature coefficient to be trimmed easily.

The LM136-2.5 series is useful as a precision 2.5V low voltage reference for digital voltmeters, power supplies or op amp circuitry. The 2.5V make it convenient to obtain a stable reference from 5V logic supplies. Further, since the LM136-2.5 operates as a shunt regulator, it can be used as either a positive or negative voltage reference.

The LM136-2.5 is rated for operation over -55°C to +125°C while the LM236-2.5 is rated over a -25°C to +85°C temperature range.

The LM336-2.5 is rated for operation over a 0°C to +70°C temperature range. See the connection diagrams for available packages.

Features

- Low temperature coefficient
- Wide operating current of 400 μA to 10 mA
- 0.2Ω dynamic impedance
- ±1% initial tolerance available
- Guaranteed temperature stability
- Easily trimmed for minimum temperature drift
- Fast turn-on

Connection Diagrams

TO-92
Plastic Package

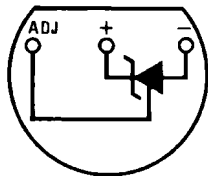

571508

Bottom View
Order Number LM336Z-2.5 or LM336BZ-2.5
See NS Package Number Z03A

TO-46
Metal Can Package

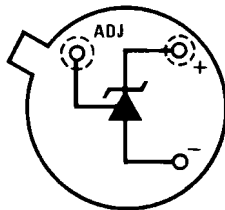

571520

Bottom View
Order Number LM136H-2.5,
LM136H-2.5/883, LM236H-2.5,
or LM236AH-2.5
See NS Package Number H03H

SO Package

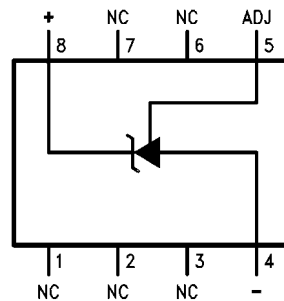

571512

Top View
Order Number LM236M-2.5,
LM236AM-2.5, LM336M-2.5
or LM336BM-2.5
See NS Package Number M08A

Typical Applications

2.5V Reference

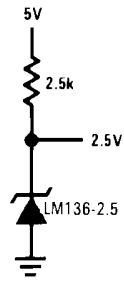

571509

2.5V Reference with Minimum Temperature Coefficient

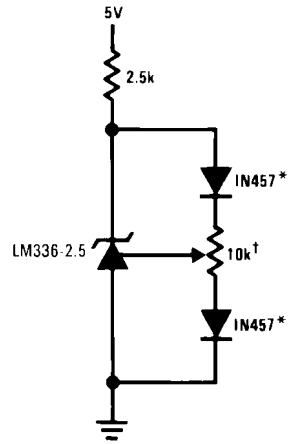

571510

†Adjust to 2.490V

*Any silicon signal diode

Wide Input Range Reference

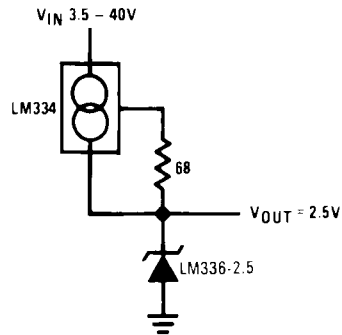

571511

Absolute Maximum Ratings (Note 1)

If Military/Aerospace specified devices are required, please contact the National Semiconductor Sales Office/Distributors for availability and specifications.

Reverse Current	15 mA
Forward Current	10 mA
Storage Temperature	-60°C to +150°C
Operating Temperature Range (Note 2)	
LM136	-55°C to +150°C
LM236	-25°C to +85°C

LM336 0°C to +70°C

Soldering Information

TO-92 Package (10 sec.)	260°C
TO-46 Package (10 sec.)	300°C
SO Package	
Vapor Phase (60 sec.)	215°C
Infrared (15 sec.)	220°C

See AN-450 "Surface Mounting Methods and Their Effect on Product Reliability" (Appendix D) for other methods of soldering surface mount devices.

Electrical Characteristics (Note 3)

Parameter	Conditions	LM136A-2.5/LM236A-2.5			LM336B-2.5			Units
		LM136-2.5/LM236-2.5			LM336-2.5			
		Min	Typ	Max	Min	Typ	Max	
Reverse Breakdown Voltage	$T_A=25^\circ\text{C}$, $I_R=1\text{ mA}$							
	LM136, LM236, LM336	2.440	2.490	2.540	2.390	2.490	2.590	V
	LM136A, LM236A, LM336B	2.465	2.490	2.515	2.440	2.490	2.540	V
Reverse Breakdown Change With Current	$T_A=25^\circ\text{C}$, $400\ \mu\text{A}\leq I_R\leq 10\text{ mA}$		2.6	6		2.6	10	mV
Reverse Dynamic Impedance	$T_A=25^\circ\text{C}$, $I_R=1\text{ mA}$, $f=100\text{ Hz}$		0.2	0.6		0.2	1	Ω
Temperature Stability (Note 4)	V_R Adjusted to 2.490V $I_R=1\text{ mA}$, <i>Figure 2</i> $0^\circ\text{C}\leq T_A\leq 70^\circ\text{C}$ (LM336)					1.8	6	mV
	$-25^\circ\text{C}\leq T_A\leq +85^\circ\text{C}$ (LM236H, LM236Z)		3.5	9				mV
	$-25^\circ\text{C}\leq T_A\leq +85^\circ\text{C}$ (LM236M)		7.5	18				mV
	$-55^\circ\text{C}\leq T_A\leq +125^\circ\text{C}$ (LM136)		12	18				mV
Reverse Breakdown Change With Current	$400\ \mu\text{A}\leq I_R\leq 10\text{ mA}$		3	10		3	12	mV
Reverse Dynamic Impedance	$I_R=1\text{ mA}$		0.4	1		0.4	1.4	Ω
Long Term Stability	$T_A=25^\circ\text{C}\pm 0.1^\circ\text{C}$, $I_R=1\text{ mA}$, $t=1000\text{ hrs}$		20			20		ppm

Note 1: Absolute Maximum Ratings indicate limits beyond which damage to the device may occur. Electrical specifications do not apply when operating the device beyond its specified operating conditions.

Note 2: For elevated temperature operation, T_j max is:

LM136	150°C
LM236	125°C
LM336	100°C

Thermal Resistance	TO-92	TO-46	SO-8
θ_{ja} (Junction to Ambient)	180°C/W (0.4 leads) 170°C/W (0.125 lead)	440°C/W	165°C/W
θ_{jc} (Junction to Case)	n/a	80°C/W	n/a

Note 3: Unless otherwise specified, the LM136-2.5 is specified from $-55^{\circ}\text{C} \leq T_A \leq +125^{\circ}\text{C}$, the LM236-2.5 from $-25^{\circ}\text{C} \leq T_A \leq +85^{\circ}\text{C}$ and the LM336-2.5 from $0^{\circ}\text{C} \leq T_A \leq +70^{\circ}\text{C}$.

Note 4: Temperature stability for the LM336 and LM236 family is guaranteed by design. Design limits are guaranteed (but not 100% production tested) over the indicated temperature and supply voltage ranges. These limits are not used to calculate outgoing quality levels. Stability is defined as the maximum change in V_{ref} from 25°C to T_A (min) or T_A (max).

Typical Performance Characteristics

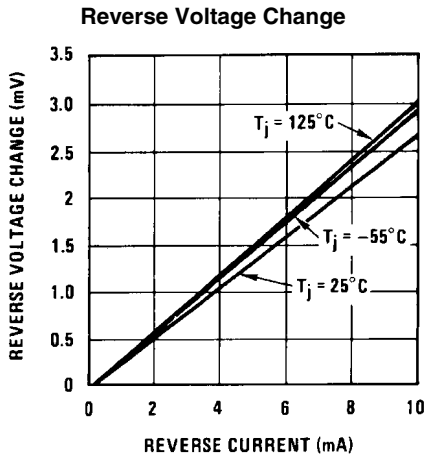

571521

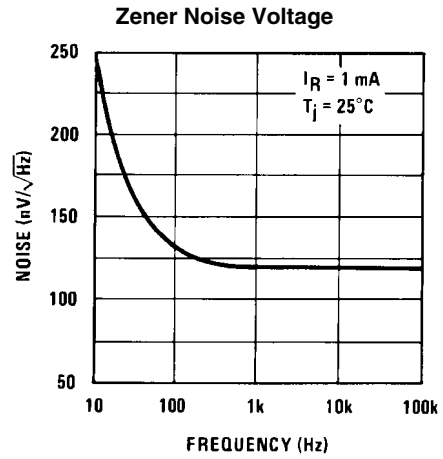

571522

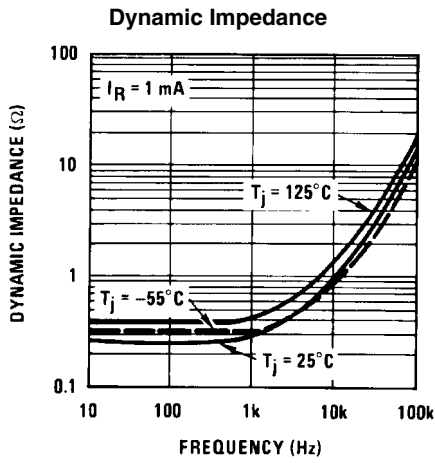

571523

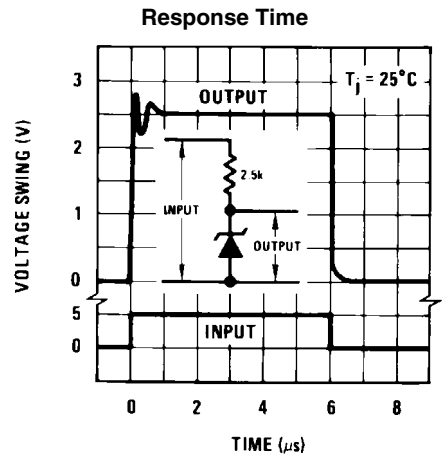

571524

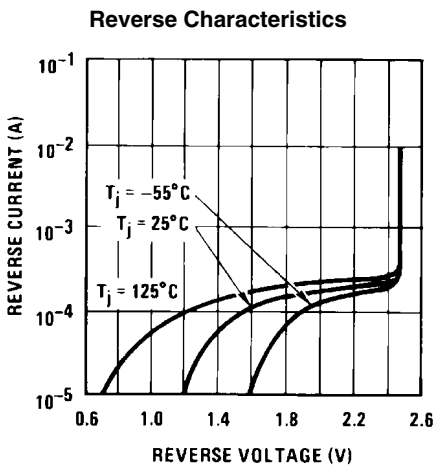

571525

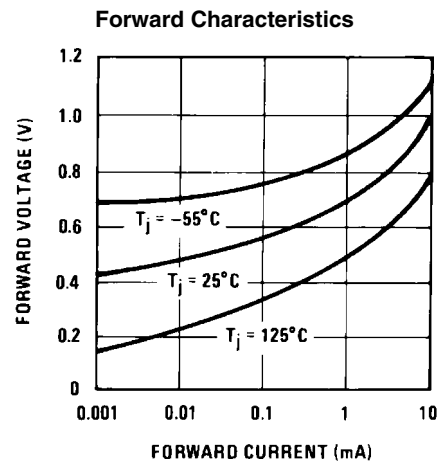

571526

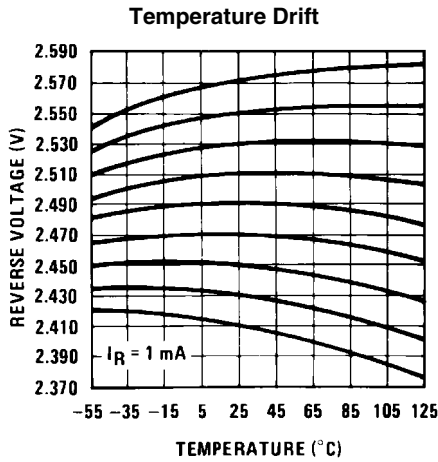

571527

Application Hints

The LM136 series voltage references are much easier to use than ordinary zener diodes. Their low impedance and wide operating current range simplify biasing in almost any circuit. Further, either the breakdown voltage or the temperature coefficient can be adjusted to optimize circuit performance.

Figure 1 shows an LM136 with a 10k potentiometer for adjusting the reverse breakdown voltage. With the addition of R1 the breakdown voltage can be adjusted without affecting the temperature coefficient of the device. The adjustment range is usually sufficient to adjust for both the initial device tolerance and inaccuracies in buffer circuitry.

If minimum temperature coefficient is desired, two diodes can be added in series with the adjustment potentiometer as shown in Figure 2. When the device is adjusted to 2.490V the temperature coefficient is minimized. Almost any silicon signal diode can be used for this purpose such as a 1N914, 1N4148 or a 1N457. For proper temperature compensation the diodes should be in the same thermal environment as the LM136. It is usually sufficient to mount the diodes near the LM136 on the printed circuit board. The absolute resistance of R1 is not critical and any value from 2k to 20k will work.

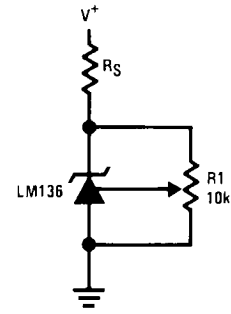

571528

FIGURE 1. LM136 With Pot for Adjustment of Breakdown Voltage (Trim Range = ±120 mV typical)

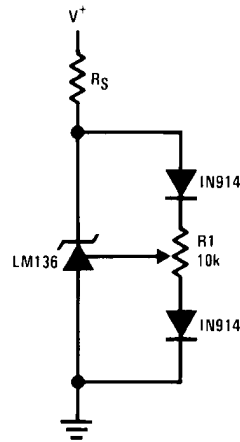

571529

FIGURE 2. Temperature Coefficient Adjustment (Trim Range = ±70 mV typical)

Low Cost 2 Amp Switching Regulator†

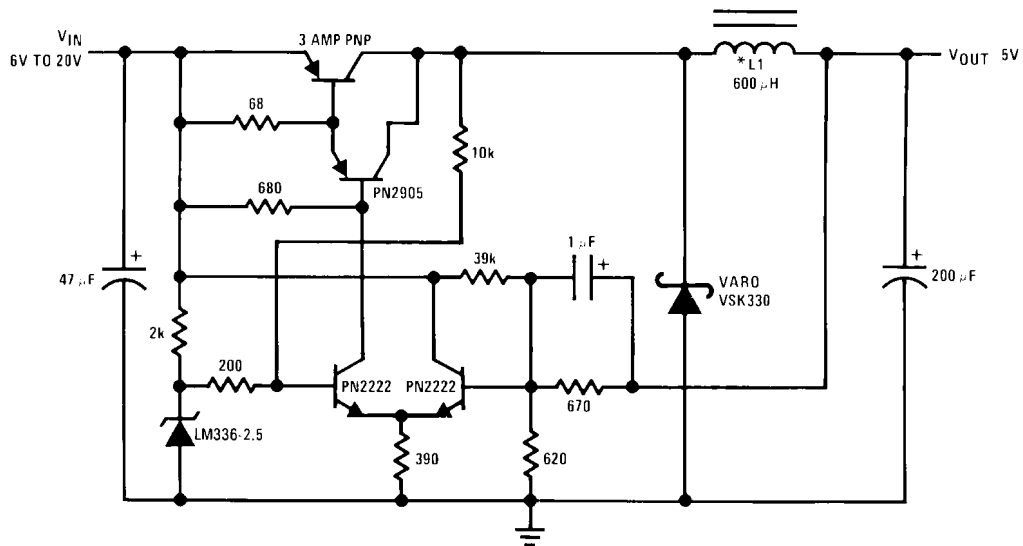

571505

*L1 60 turns #16 wire on Arnold Core A-254168-2

†Efficiency ≈ 80%

Precision Power Regulator with Low Temperature Coefficient

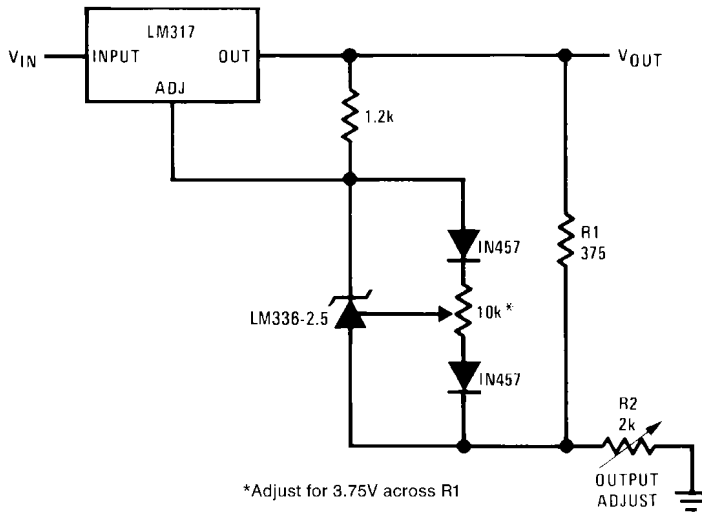

5V Crowbar

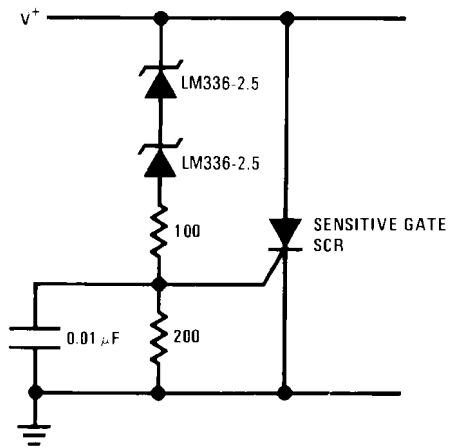

Trimmed 2.5V Reference with Temperature Coefficient Independent of Breakdown Voltage

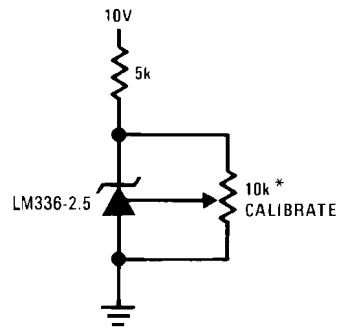

*Does not affect temperature coefficient

571514

Adjustable Shunt Regulator

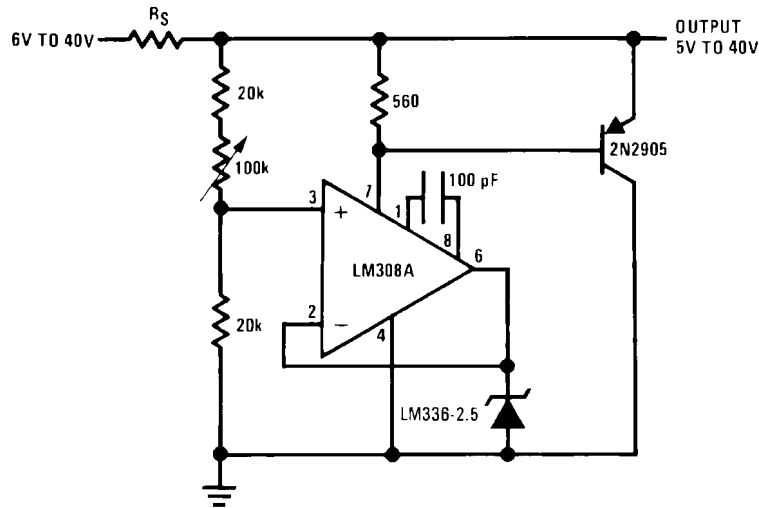

571506

Linear Ohmmeter

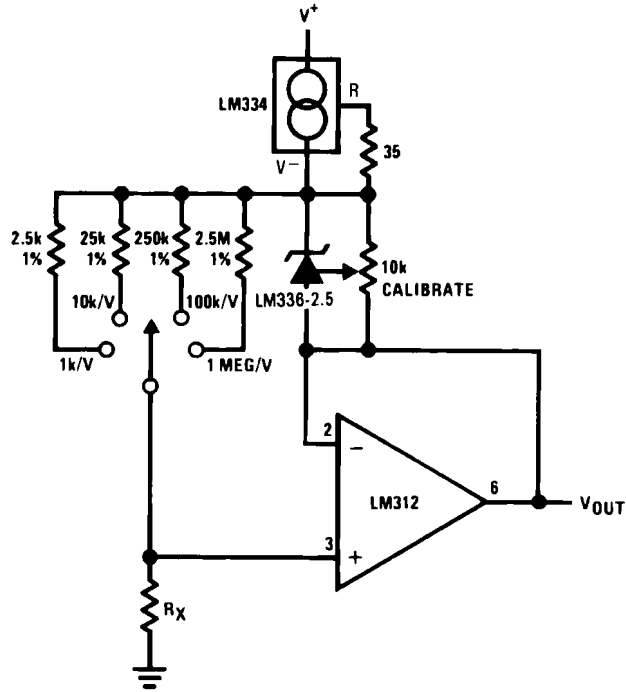

571516

Op Amp with Output Clamped

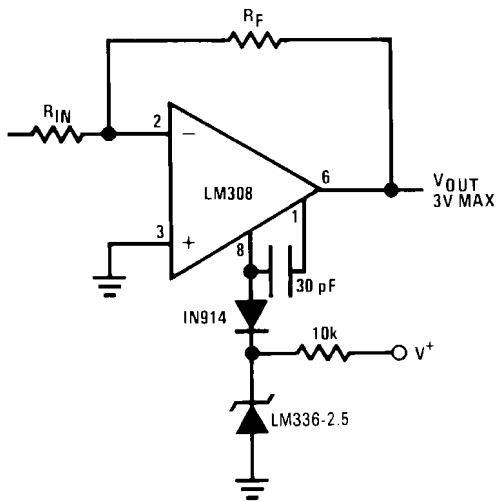

571517

Bipolar Output Reference

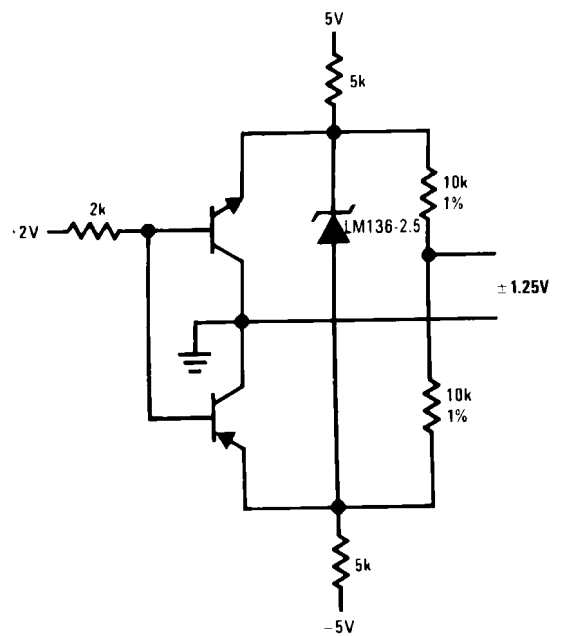

571518

2.5V Square Wave Calibrator

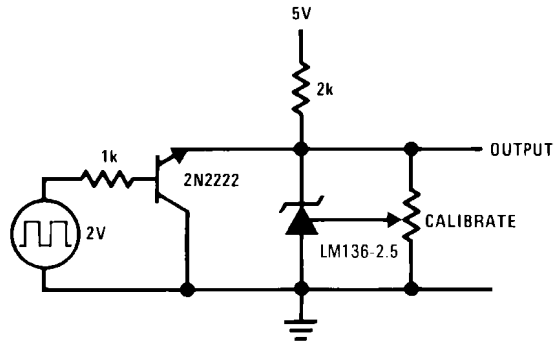

571519

5V Buffered Reference

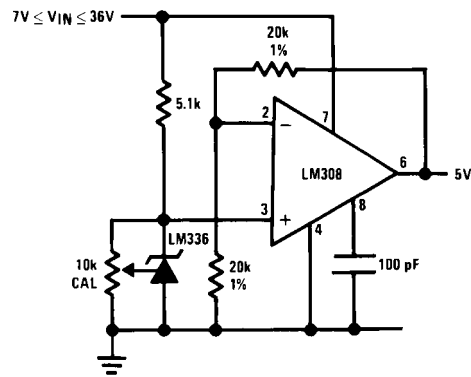

571530

Low Noise Buffered Reference

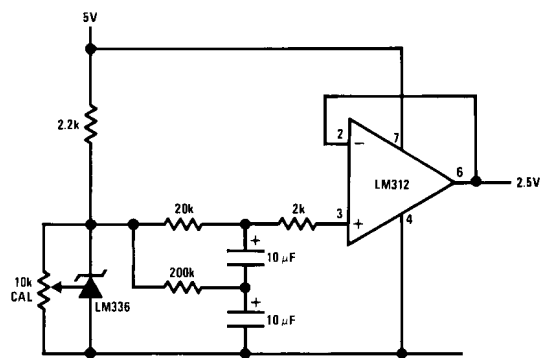

571531

Schematic Diagram

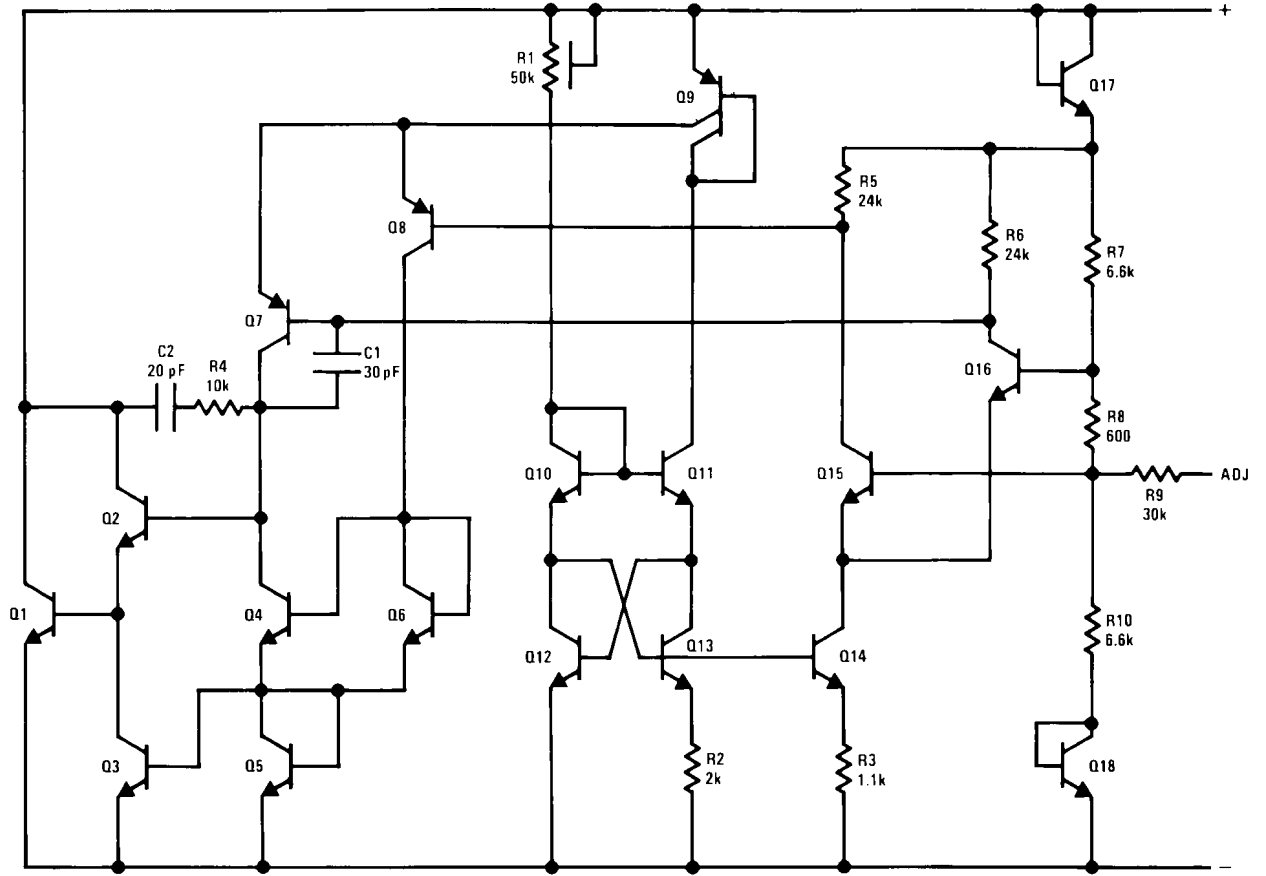

571501

Physical Dimensions inches (millimeters) unless otherwise noted

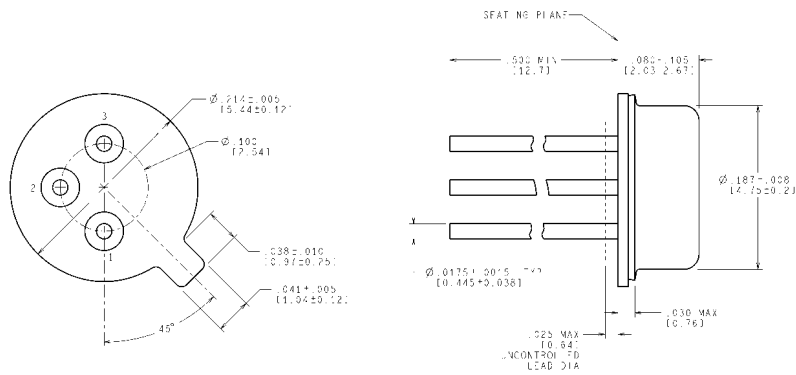

CONTROLLING DIMENSION IS INCH
VALUES IN [] ARE IN MILLIMETERS

H03H (Rev F)

Order Number LM136H-2.5, LM136H-2.5/883, LM236H-2.5, LM136AH-2.5, LM136AH-2.5/883 or LM236AH-2.5
NS Package Number H03H

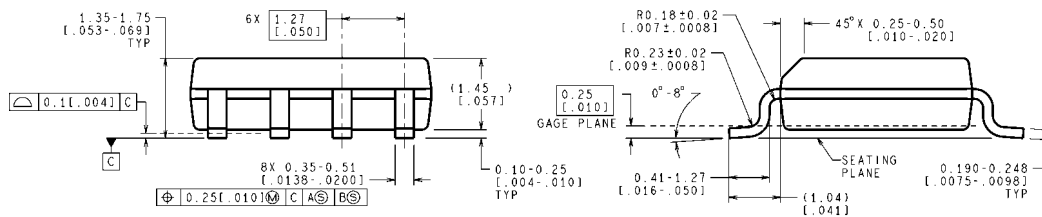
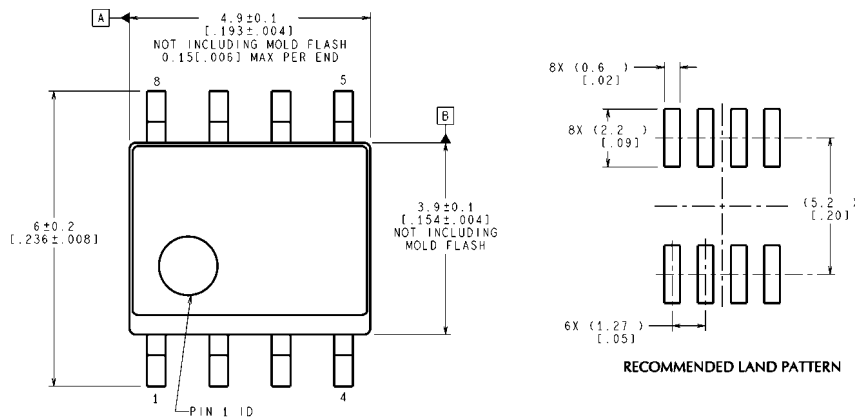

CONTROLLING DIMENSION IS MILLIMETER
VALUES IN [] ARE INCHES
DIMENSIONS IN () FOR REFERENCE ONLY

M08A (Rev L)

Small Outline (SO) Package (M)
Order Number LM236M-2.5, LM236AM-2.5, LM336M-2.5 or LM336BM-2.5
NS Package Number M08A

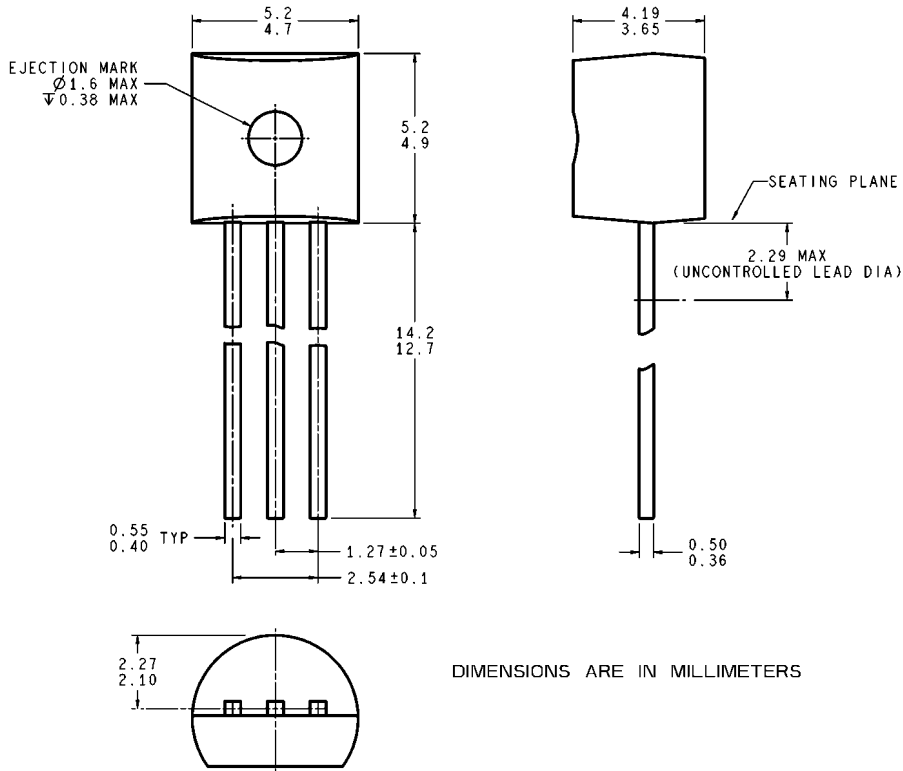

DIMENSIONS ARE IN MILLIMETERS

Z03A (Rev G)

TO-92 Plastic Package (Z)
Order Number LM336Z-2.5 or LM336BZ-2.5
NS Package Number Z03A

Notes

LM136-2.5/LM236-2.5/LM336-2.5V

Notes

For more National Semiconductor product information and proven design tools, visit the following Web sites at:

Products		Design Support	
Amplifiers	www.national.com/amplifiers	WEBENCH® Tools	www.national.com/webench
Audio	www.national.com/audio	App Notes	www.national.com/appnotes
Clock and Timing	www.national.com/timing	Reference Designs	www.national.com/refdesigns
Data Converters	www.national.com/adc	Samples	www.national.com/samples
Interface	www.national.com/interface	Eval Boards	www.national.com/evalboards
LVDS	www.national.com/lvds	Packaging	www.national.com/packaging
Power Management	www.national.com/power	Green Compliance	www.national.com/quality/green
Switching Regulators	www.national.com/switchers	Distributors	www.national.com/contacts
LDOs	www.national.com/ldo	Quality and Reliability	www.national.com/quality
LED Lighting	www.national.com/led	Feedback/Support	www.national.com/feedback
Voltage Reference	www.national.com/vref	Design Made Easy	www.national.com/easy
PowerWise® Solutions	www.national.com/powerwise	Solutions	www.national.com/solutions
Serial Digital Interface (SDI)	www.national.com/sdi	Mil/Aero	www.national.com/milaero
Temperature Sensors	www.national.com/tempsensors	SolarMagic™	www.national.com/solarmagic
Wireless (PLL/VCO)	www.national.com/wireless	Analog University®	www.national.com/AU

THE CONTENTS OF THIS DOCUMENT ARE PROVIDED IN CONNECTION WITH NATIONAL SEMICONDUCTOR CORPORATION ("NATIONAL") PRODUCTS. NATIONAL MAKES NO REPRESENTATIONS OR WARRANTIES WITH RESPECT TO THE ACCURACY OR COMPLETENESS OF THE CONTENTS OF THIS PUBLICATION AND RESERVES THE RIGHT TO MAKE CHANGES TO SPECIFICATIONS AND PRODUCT DESCRIPTIONS AT ANY TIME WITHOUT NOTICE. NO LICENSE, WHETHER EXPRESS, IMPLIED, ARISING BY ESTOPPEL OR OTHERWISE, TO ANY INTELLECTUAL PROPERTY RIGHTS IS GRANTED BY THIS DOCUMENT.

TESTING AND OTHER QUALITY CONTROLS ARE USED TO THE EXTENT NATIONAL DEEMS NECESSARY TO SUPPORT NATIONAL'S PRODUCT WARRANTY. EXCEPT WHERE MANDATED BY GOVERNMENT REQUIREMENTS, TESTING OF ALL PARAMETERS OF EACH PRODUCT IS NOT NECESSARILY PERFORMED. NATIONAL ASSUMES NO LIABILITY FOR APPLICATIONS ASSISTANCE OR BUYER PRODUCT DESIGN. BUYERS ARE RESPONSIBLE FOR THEIR PRODUCTS AND APPLICATIONS USING NATIONAL COMPONENTS. PRIOR TO USING OR DISTRIBUTING ANY PRODUCTS THAT INCLUDE NATIONAL COMPONENTS, BUYERS SHOULD PROVIDE ADEQUATE DESIGN, TESTING AND OPERATING SAFEGUARDS.

EXCEPT AS PROVIDED IN NATIONAL'S TERMS AND CONDITIONS OF SALE FOR SUCH PRODUCTS, NATIONAL ASSUMES NO LIABILITY WHATSOEVER, AND NATIONAL DISCLAIMS ANY EXPRESS OR IMPLIED WARRANTY RELATING TO THE SALE AND/OR USE OF NATIONAL PRODUCTS INCLUDING LIABILITY OR WARRANTIES RELATING TO FITNESS FOR A PARTICULAR PURPOSE, MERCHANTABILITY, OR INFRINGEMENT OF ANY PATENT, COPYRIGHT OR OTHER INTELLECTUAL PROPERTY RIGHT.

LIFE SUPPORT POLICY

NATIONAL'S PRODUCTS ARE NOT AUTHORIZED FOR USE AS CRITICAL COMPONENTS IN LIFE SUPPORT DEVICES OR SYSTEMS WITHOUT THE EXPRESS PRIOR WRITTEN APPROVAL OF THE CHIEF EXECUTIVE OFFICER AND GENERAL COUNSEL OF NATIONAL SEMICONDUCTOR CORPORATION. As used herein:

Life support devices or systems are devices which (a) are intended for surgical implant into the body, or (b) support or sustain life and whose failure to perform when properly used in accordance with instructions for use provided in the labeling can be reasonably expected to result in a significant injury to the user. A critical component is any component in a life support device or system whose failure to perform can be reasonably expected to cause the failure of the life support device or system or to affect its safety or effectiveness.

National Semiconductor and the National Semiconductor logo are registered trademarks of National Semiconductor Corporation. All other brand or product names may be trademarks or registered trademarks of their respective holders.

Copyright© 2009 National Semiconductor Corporation

For the most current product information visit us at www.national.com



**National Semiconductor
Americas Technical
Support Center**
Email: support@nsc.com
Tel: 1-800-272-9959

**National Semiconductor Europe
Technical Support Center**
Email: europe.support@nsc.com

**National Semiconductor Asia
Pacific Technical Support Center**
Email: ap.support@nsc.com

**National Semiconductor Japan
Technical Support Center**
Email: jpn.feedback@nsc.com