

LIGHTING CONNECTORS

OPERATING INFORMATION

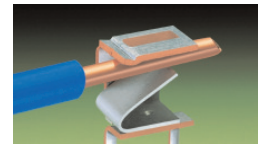

224 Series Lighting connectors - for solid, stranded and flexible conductors

ALL the connectors on this sheet are designed to HELP REDUCE ON SITE WIRING TIME by as much as 50%

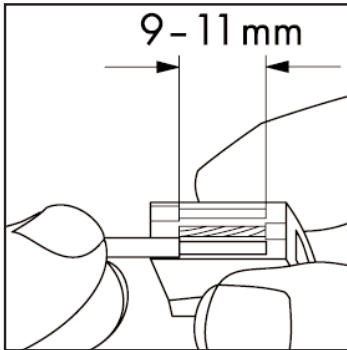

Strip both the conductors 9 - 11mm

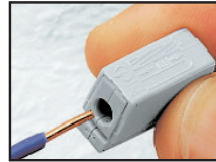

Push the supply cable (SOLID) into the BACK of the connector

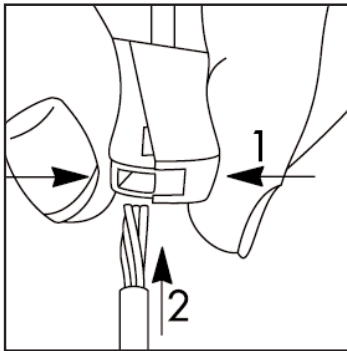
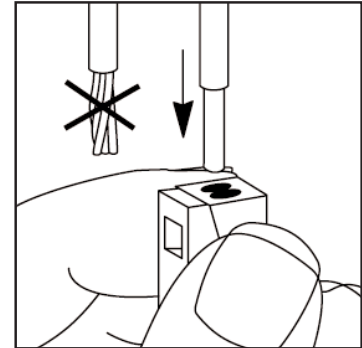

Squeeze the FRONT of the connector to OPEN the Cage Clamp and insert the load cable (FLEXIBLE) then release to CLOSE

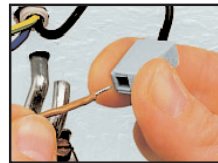

Testing is still possible using the integral points

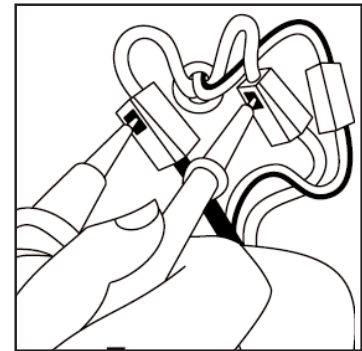

RESULT: a safe, touchproof connection, made without the use of insulation tape or screwdriver or by twisting wires together. This connector is so easy to use the only thing needed is the pre-stripped conductor!



224-101

2 Conductor connector
Supply side 1.0 - 2.5mm² solid
Load side 0.5 - 2.5mm² solid or flexible
400V/4kV/2 - 24A

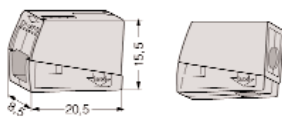

224-112

3 Conductor connector
Supply side 2 x 1.0 - 2.5mm² solid
Load side 0.5 - 2.5mm² solid or flexible
400V/4kV/2 - 24A

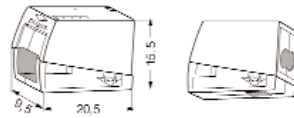

224-201

2 Conductor connector
Supply side 0.5 - 2.5mm² solid or flexible
Load side 0.5 - 2.5mm² solid or flexible
400V/4kV/2 - 24A

