



Assembly Tooling and Accessories

Tooling

■ XG4 / XG2 - Flat Cable Sockets and Bus Connectors

IDC Press

XY2B-0002

IDC Press Tool (Attachments sold separately)

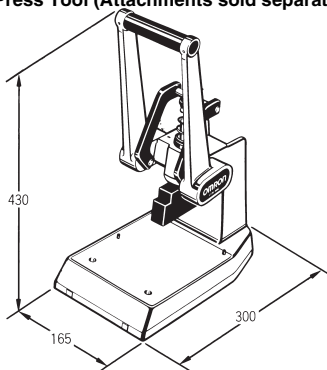

IDC Press Attachments for terminating XG4M and XG2A

XY2B-1007

Base attachment for the XG4M

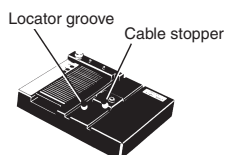

XY2B-1006

Base attachment for the XG2A

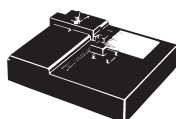

Operation

XG4M-series Connectors must be placed face down into the locator slot of the Attachment. (With the XG2A Series, place the terminal block in the Attachment.)

Insert the cable until it is flush against the cable stopper. Connections are made by pulling the handle towards you until it stops. For details on operation, see the user's manual supplied with the IDC Tool.

Note: An additional head attachment or spacer is not needed to terminate the XG4M and XG2A connectors.

| IDC Press | Base Attachment | Applicable Socket |
|-----------|-----------------|---------------------|
| XY2B-0002 | XY2B-1007 | XG4M (All contacts) |
| | XY2B-1006 | XG2A (All contacts) |

IDC Press Attachments for XG4E

XY2B-1004

Base attachment for the XG4E



XY2B-14□□

Spacer for the XG4E (See below)

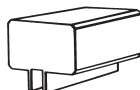

Operation

XG4E-series Connectors must be placed face down into the locator slot of the Attachment. Insert the cable until it is flush against the cable stopper.

Next set the proper spacer for the Plug.

Connections are made by pulling the handle towards you until it stops.

| IDC Tool | Base Attachment | Spacer | Applicable Plug |
|-----------|-----------------|-----------|------------------------------------|
| XY2B-0002 | XY2B-1004 | XY2B-1401 | XG4E-10□1/-10□2 XG4E-1431/-1432 |
| | | XY2B-1402 | XG4E-1631/-1632 XG4E-2031/-2032 |
| | | XY2B-1403 | XG4E-2631/-2632 XG4E-3031/-3032 |
| | | XY2B-1404 | XG4E-3431/-3432 |
| | | XY2B-1405 | XG4E-4031/-4032 |
| | | XY2B-1406 | XG4E-50□1/-50□2 |
| | | XY2B-1407 | XG4E-60□1/-60□2 XG4E-54□1/-64□2 |

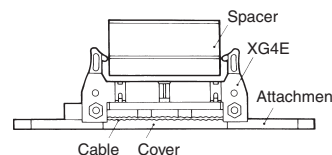

■ XG5 - Discrete Wire Sockets

Manual IDC Termination Tool

XY2B-7006

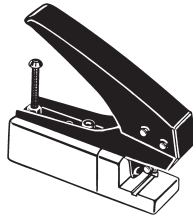

This tool is a compact, light-weight model, ideal for use in the laboratory or for maintenance.

Specifications

| | |
|----------------------|---|
| Applicable connector | XG5M-N |
| Applicable wire | AWG24 to AWG28 (with an insulation outer diameter of 1.1 to 1.3 mm) |
| Dimensions | 25 (W) × 100 (L) × 80 (H) |
| Weight | Approx. 180 g |

Automated Wire IDC Tool Set

XY2B-2104-N

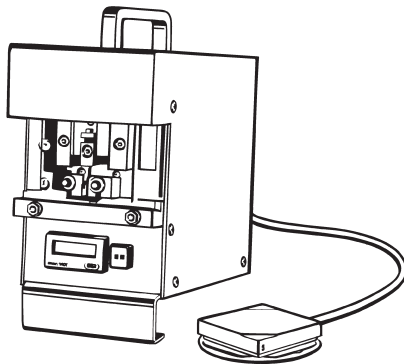

This Wire IDC Tool Set is designed for XG5 Discrete-wire Connectors.

Specifications

| | |
|---------------|--------------------------------|
| Stroke | 13 mm |
| Motor speed | 83/100 rpm (50/60 Hz) |
| Feed pitch | 2.54 mm |
| Operation | Foot switch |
| Weight | About 6 kg |
| Rated voltage | 0.5 A, 100 VAC (50/60 Hz) |
| Fuse | 1 A |
| Dimensions | 120 × 200 × 225 mm (W × H × D) |

Note: For function and operation details, see the user's manual for the Pressure Welder provided separately.

Contact Removal Tool

XY2E-0001

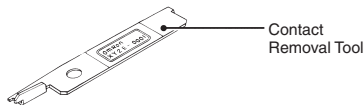

Used to remove contacts, which need to be replaced or reconfigured, from the housing.

Replacing Contacts

Use only this tool to remove incorrect IDC contacts.

1. Remove the cover.
2. Insert the tool into the housing lance holes and push the lance into the housing.
3. Pull out the contact while holding the lance down.
4. Insert a new contact.

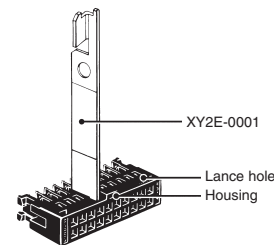

Applicable Connectors and Wires

| Applicable Connector | Size No. | Applicable wires | | | |
|---|----------|------------------|-----------------------------------|---------------------------|------------------------|
| | | UL file No. | Size [No. of wires/diameter] (mm) | Cross-sectional area (mm) | Covering diameter (mm) |
| XG5M-□□31-N XG5M-□□32-N XG5M-□□33-N | No. 1 | UL1061 | AWG24 [7/0.203] | 0.21 | 1.10 |
| XG5M-□□34-N XG5M-□□35-N XG5M-□□36-N | No. 2 | UL1007 | AWG26 [7/0.16] AWG28 [7/0.127] | 0.13 0.09 | 1.30 1.22 |

Note: Use only wires specified in the table above

Accessories - XG4 / XG5 / XG8

External Polarization Options

The following optional accessories can be used to provide polarization to sockets and plugs that do not have molded polarizing guides and slots built into their housings and shrouds.

Solutions for Shrouded Connectors

XG4Z-0004 Polarizing Key

Typically, 10 contact versions of the XG4A, XG4E and XG4C are available with or without polarizing guides.

Install the XG4Z-0004 polarizing key on XG4A pcb sockets, XG4E plugs and XG4C pcb sockets that do not have a polarizing slot, to prevent reverse connection with XG4M cable sockets that do not have a polarizing guide.

For all other versions, the molded polarity guides and slots can be used by themselves to help prevent reverse insertion. However, use the polarizing key with these versions as well for best results.

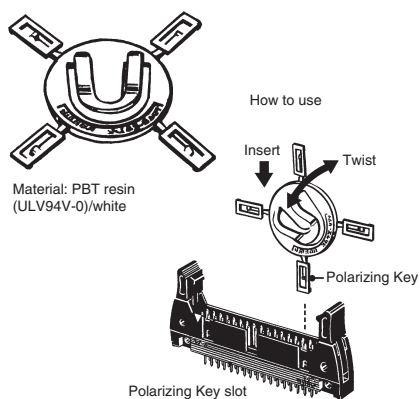

Note: Each XG4Z-0004 has 4 Polarizing Keys.

Solutions for Unshrouded Connectors

Use the XG4Z-0005 coding pin to fill a specific hole in one of the XG4 or XG5 sockets. Then, use the XY2E-0002 cutting pin to remove the corresponding terminal from an XG8 unshrouded plug. (See XG5 and XG8 datasheets for details about those connectors.)

XG4Z-0005 Coding Pin

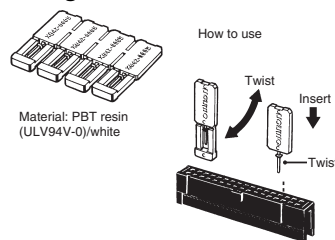

Note: 1. A contact with a Coding Pin inserted cannot be used.
2. Each XG4Z-0005 has 4 Polarizing Keys.

XY2E-0002 Contact Cutting Driver

The Contact Cutting Driver is used to cut (twist off) a contact on the mating Plug when using an XG4Z-0005 Coding Pin.

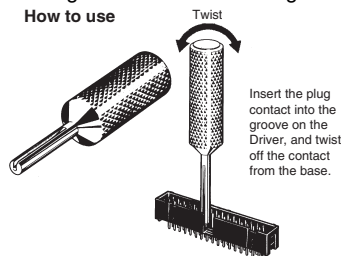

Top Lock Levers

XG5Z-0002 - "Lock Lever"

Use to lock right angle XG8B and XG8W Plugs to mating sockets

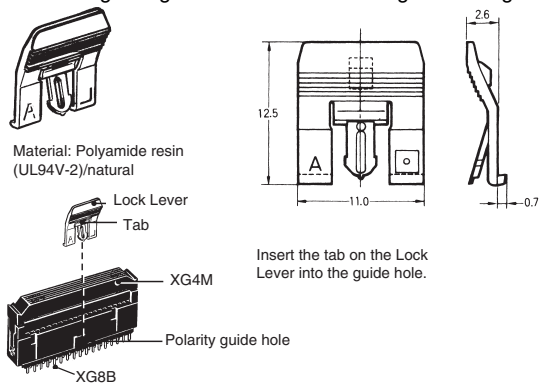

XG4Z-0002 - "Lock Lever II"

Use to lock XG4C Box-type Plugs to mating sockets.

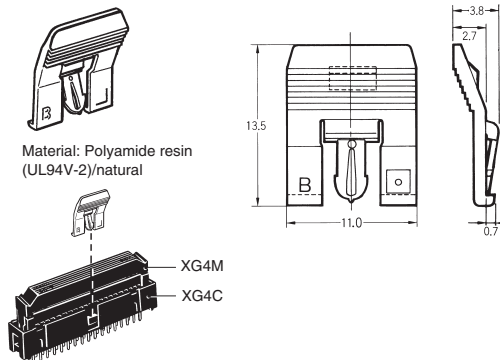

XG5 - Spare Contacts

XG5W-0031-N (Size #1)

XG5W-0034-N (Size #2)

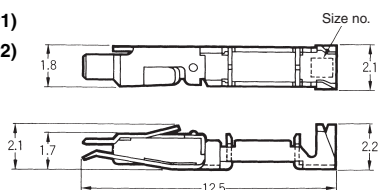

| Model | Order in Multiples of |
|-------------|-----------------------|
| XG5W-0031-N | 100 |
| XG5W-0034-N | |

Note: 1. These Contacts can be used as replacements if a wrong connection is made.
2. The applicable wire for size No. 1 is AWG24 (UL-1061). The applicable wire for size No. 2 is AWG26 to AWG28 (UL-1007).

All sales are subject to Omron Electronic Components LLC standard terms and conditions of sale, which can be found at http://www.components.omron.com/components/web/webfiles.nsf/sales_terms.html

ALL DIMENSIONS SHOWN ARE IN MILLIMETERS.
To convert millimeters into inches, multiply by 0.03937. To convert grams into ounces, multiply by 0.03527.

OMRON[®]
**OMRON ELECTRONIC
COMPONENTS LLC**
55 E. Commerce Drive, Suite B
Schaumburg, IL 60173
847-882-2288

OMRON ON-LINE
Global - <http://www.omron.com>
USA - <http://www.components.omron.com>

Cat. No. X304-E-1

11/10

Specifications subject to change without notice

Printed in USA

XG□ Assembly Tooling and Accessories