

REV. Q

DIMENSIONS ARE IN INCHES UNLESS OTHERWISE NOTED TOLERANCES ARE:
 ONE PLACE DECIMALS ± .1[2.54] THREE PLACE DECIMALS ± .005[.13]
 TWO PLACE DECIMALS ± .01[.25] FOUR PLACE DECIMALS ± .0010[.025] ANGLES ± 1°

TITLE: .050 x .050 DUAL TERMINAL ASSEMBLY MIXED TECHNOLOGY
 DWG NO: FTSH-1XX-XX-XX-MT-XX
 SHEET 1 OF 1

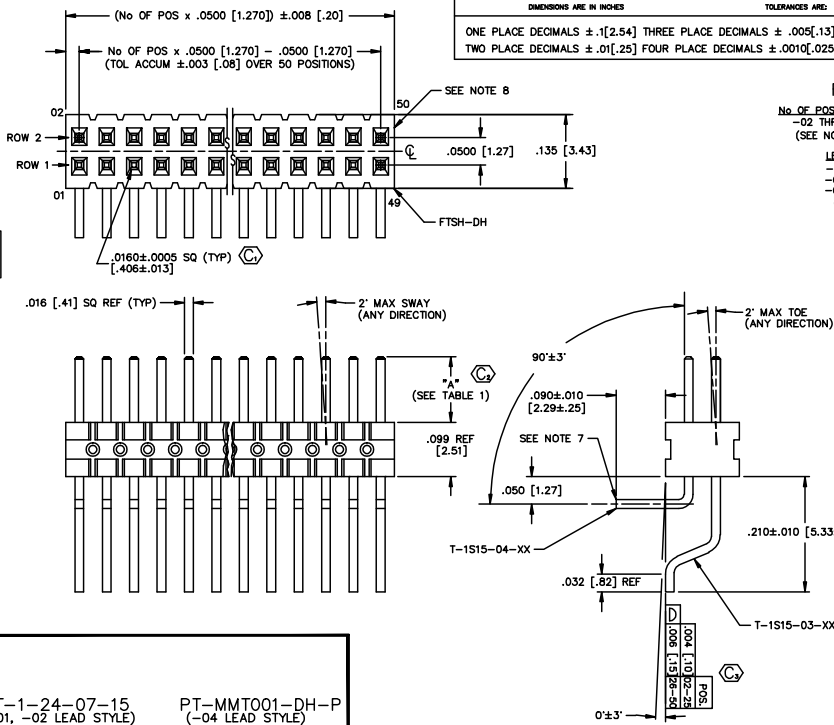

FTSH-1XX-XX-XX-MT-XX
 No. OF POS. PER ROW -02 THRU -50 (SEE NOTE 2 & 5)
 LEAD STYLE
 -01: "A" = .120 [3.05]
 -02: "A" = .075 [1.91]
 -04: "A" = .150 [3.81]
 (SEE TABLE 1 FOR TERMINAL USAGE)
 PLATING
 -L: LIGHT SELECTIVE (USE T-1S15-04-L & T-1S15-03-L)
 -F: FLASH SELECTIVE (USE T-1S15-04-F & T-1S15-03-F)
 -S: SELECTIVE GOLD (USE T-1S15-04-S & T-1S15-03-S)
 -H: HEAVY GOLD (USE T-1S15-04-H & T-1S15-03-H)
 -SM: HEAVY SELECTIVE GOLD, MATTE TIN TAIL (USE T-1S15-04-S & T-1S15-03-S)
 -LM: LIGHT SELECTIVE GOLD, MATTE TIN TAIL (USE T-1S15-04-L & T-1S15-03-L)
 -FM: FLASH SELECTIVE GOLD, MATTE TIN TAIL (USE T-1S15-04-F & T-1S15-03-F)
 -TM: MATTE TIN (USE T-1S15-04-T & T-1S15-03-T)

- NOTES:
 1. TERMINALS TO BE SHEARED TO MEET DIMENSION SPECIFICATION.
 2. PARTS MAY BE CUT TO POSITION.
 3. MINIMUM PUSHOUT FORCE: .5 LB.
 4. MAXIMUM TOP / BOTTOM BOW: .004 [.10].
 5. SEE PACKAGING TABLE 2.
 6. [C] REPRESENTS A CRITICAL DIMENSION
 7. .002 MAX BURR ALLOWED.
 8. .015 MAX CUT FLASH ALLOWED.
 9. PINS 2 TO BE FLUSH TO .003 ABOVE OR BELOW LINE MADE BY BODY.

LEAD STYLE	"A"	ROW 1	ROW 2
-01	.120 ± .005 [3.05 ± .13]	T-1S15-04-XX	T-1S15-03-XX
-02	.075 ± .005 [1.91 ± .13]	T-1S15-04-XX	T-1S15-03-XX
-04	.150 ± .005 [3.81 ± .13]	T-1S15-04-XX	T-1S15-03-XX

LEAD STYLE	NO. OF POS	PACKAGING
-01	-02 THRU -04	TAPE & REEL
-01	-05 THRU -50	PT-1-24-07-15
-02	-02 THRU -05	TAPE & REEL
-02	-06 THRU -50	PT-1-24-07-15
-04	-02 THRU -03	TAPE & REEL
-04	-04 THRU -50	PT-MMT001-DH-P

PLOT SCALE: 1=1.3125/ DIM SCALE: 1=1.000

samtec

520 PARK EAST BLVD. NEW ALBANY, INDIANA 47150
 PHONE (812) 944-6733 P.O. BOX 1147
 CODE 55322

MADE BY: PURVIS 07-29-96 FTSH-1XX-XX-XX-MT-XX
 SHEET 1 OF 1

DO NOT SCALE FROM THIS PRINT

PT-1-24-07-15
 (-01, -02 LEAD STYLE)
 TUBE TO USE (2) TP-03

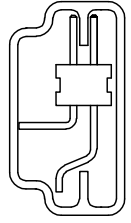

PT-MMT001-DH-P
 (-04 LEAD STYLE)
 TUBE TO USE (2) TP-09

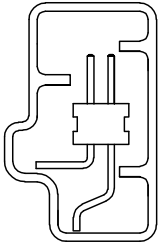

IN-PROCESS 1

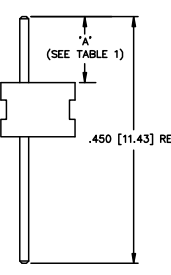

IN-PROCESS 2

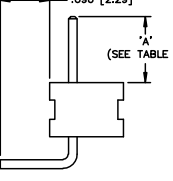

IN-PROCESS 3

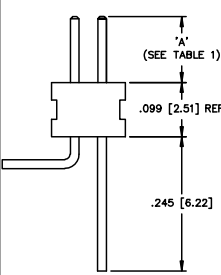

PROPRIETARY NOTE
 THIS DOCUMENT CONTAINS INFORMATION CONFIDENTIAL AND PROPRIETARY TO SAMTEC INC AND SHALL NOT BE REPRODUCED OR TRANSMITTED IN ANY FORM OR BY ANY MEANS, ELECTRONIC OR MECHANICAL, INCLUDING PHOTOCOPYING, RECORDING, OR BY ANY INFORMATION STORAGE AND RETRIEVAL SYSTEM, WITHOUT THE WRITTEN CONSENT OF SAMTEC INC.