

HITACHI

KAOHSIUNG HITACHI
ELECTRONICS CO.,LTD
P.O. BOX 26-27
2,13TH EAST ST.K.E.P.Z.
KAOHSIUNG TAIWAN R.O.C.
TEL:(07) 8215811 (7 LINE)
FAX:(07) 821-5815

FOR MESSRS : STD

DATE : Oct.14,2008

CUSTOMER'S ACCEPTANCE SPECIFICATIONS

TX09D70VM1CDA

CONTENTS

No.	ITEM	SHEET No.	PAGE
1	COVER	7B64PS 2701-TX09D70VM1CDA-6	1-1/1
2	RECORD OF REVISION	7B64PS 2702-TX09D70VM1CDA-6	2-1/2~2/2
3	GENERAL DATA	7B64PS 2703-TX09D70VM1CDA-6	3-1/1
4	ABSOLUTE MAXIMUM RATINGS	7B64PS 2704-TX09D70VM1CDA-6	4-1/2~2/2
5	ELECTRICAL CHARACTERISTICS	7B64PS 2705-TX09D70VM1CDA-6	5-1/1
6	OPTICAL CHARACTERISTICS	7B64PS 2706-TX09D70VM1CDA-6	6-1/2~2/2
7	BLOCK DIAGRAM	7B64PS 2707-TX09D70VM1CDA-6	7-1/1
8	INTERFACE TIMING CHART	7B64PS 2708-TX09D70VM1CDA-6	8-1/6~6/6
9	DIMENSIONAL OUTLINE	7B63PS 2709-TX09D70VM1CDA-6	9-1/1
10	APPEARANCE STANDARD	7B64PS 2710-TX09D70VM1CDA-6	10-1/3~3/3
11	PRECAUTION IN DESIGN	7B64PS 2711-TX09D70VM1CDA-6	11-1/2~2/2
12	DESIGNATION OF LOT MARK	7B64PS 2712-TX09D70VM1CDA-6	12-1/1
13	PRECAUTION FOR USE	7B64PS 2713-TX09D70VM1CDA-6	13-1/1

*When product will be discontinued, customer will be informed by HITACHI with twelve months prior announcement.

ACCEPTED BY: _____

PROPOSED BY: Dan Cheng

KAOHSIUNG HITACHI ELECTRONICS CO.,LTD.	Sh. No.	7B64PS 2701-TX09D70VM1CDA-6	PAGE	1-1/1
---	------------	-----------------------------	------	-------

RECORD OF REVISION

DATE	SHEET No.	SUMMARY																																				
Nov.15,'05	7B64PS 2704- TX09D70VM1CDA-2 PAGE 4-1/2	4.1 ELECTRICAL ABSOLUTE MAXIMUM RATINGS OF LCD Revised																																				
		<table border="1" style="width: 100%; border-collapse: collapse; text-align: center;"> <thead> <tr> <th style="width: 10%;"></th> <th style="width: 50%;">ITEM</th> <th style="width: 15%;">SYMBOL</th> <th style="width: 25%;">MAX.</th> </tr> </thead> <tbody> <tr> <td rowspan="2" style="text-align: left;">LED</td> <td>Forward Current</td> <td>IF</td> <td>25</td> </tr> <tr> <td>Pulse Forward Current</td> <td>I_{FP}</td> <td>80</td> </tr> </tbody> </table> <p style="text-align: center;">↓</p> <table border="1" style="width: 100%; border-collapse: collapse; text-align: center;"> <thead> <tr> <th style="width: 10%;"></th> <th style="width: 50%;">ITEM</th> <th style="width: 15%;">SYMBOL</th> <th style="width: 25%;">MAX.</th> </tr> </thead> <tbody> <tr> <td rowspan="2" style="text-align: left;">LED</td> <td>Forward Current</td> <td>IF</td> <td>35</td> </tr> <tr> <td>Pulse Forward Current</td> <td>I_{FP}</td> <td>100</td> </tr> </tbody> </table> <p>Note 4 :</p> <div style="display: flex; justify-content: space-around;"> <div style="text-align: center;"> <p>6mA(85°C)</p> </div> <div style="text-align: center;"> <p>8.5mA (85°C)</p> </div> </div> <p>Note 5 :</p> <div style="display: flex; justify-content: space-around;"> <div style="text-align: center;"> <p>IFP Conditions : pulse width ≤ 10ms and Duty ≤ 1/10</p> <p>Ta=25°C</p> </div> <div style="text-align: center;"> <p>IFP Conditions : pulse width ≤ 10ms and Duty ≤ 1/10</p> <p>Ta=25°C</p> </div> </div>		ITEM	SYMBOL	MAX.	LED	Forward Current	IF	25	Pulse Forward Current	I _{FP}	80		ITEM	SYMBOL	MAX.	LED	Forward Current	IF	35	Pulse Forward Current	I _{FP}	100														
	ITEM	SYMBOL	MAX.																																			
LED	Forward Current	IF	25																																			
	Pulse Forward Current	I _{FP}	80																																			
	ITEM	SYMBOL	MAX.																																			
LED	Forward Current	IF	35																																			
	Pulse Forward Current	I _{FP}	100																																			
7B64PS 2705- TX09D70VM1CDA-2 PAGE 5-1/2	5.2 ELECTRICAL CHARACTERISTICS OF BACK LIGHT Revised	<table border="1" style="width: 100%; border-collapse: collapse; text-align: center;"> <thead> <tr> <th style="width: 15%;">ITEM</th> <th style="width: 15%;">SYMBOL</th> <th style="width: 15%;">CONDITION</th> <th style="width: 10%;">MAX.</th> <th style="width: 10%;">TYP.</th> <th style="width: 35%;">MAX.</th> </tr> </thead> <tbody> <tr> <td>LED Input Voltage</td> <td>VF</td> <td>IF=20mA</td> <td>-</td> <td>3.75</td> <td>4.2</td> </tr> <tr> <td>LED Forward Current</td> <td>IF</td> <td>-</td> <td>-</td> <td>20</td> <td>20</td> </tr> </tbody> </table> <p style="text-align: center;">↓</p> <table border="1" style="width: 100%; border-collapse: collapse; text-align: center;"> <thead> <tr> <th style="width: 15%;">ITEM</th> <th style="width: 15%;">SYMBOL</th> <th style="width: 15%;">CONDITION</th> <th style="width: 10%;">MAX.</th> <th style="width: 10%;">TYP.</th> <th style="width: 35%;">MAX.</th> </tr> </thead> <tbody> <tr> <td>LED Input Voltage</td> <td>VF</td> <td>IF=20mA</td> <td>-</td> <td>3.2</td> <td>3.5</td> </tr> <tr> <td>LED Forward Current</td> <td>IF</td> <td>-</td> <td>-</td> <td>20</td> <td>25</td> </tr> </tbody> </table>	ITEM	SYMBOL	CONDITION	MAX.	TYP.	MAX.	LED Input Voltage	VF	IF=20mA	-	3.75	4.2	LED Forward Current	IF	-	-	20	20	ITEM	SYMBOL	CONDITION	MAX.	TYP.	MAX.	LED Input Voltage	VF	IF=20mA	-	3.2	3.5	LED Forward Current	IF	-	-	20	25
		ITEM	SYMBOL	CONDITION	MAX.	TYP.	MAX.																															
LED Input Voltage	VF	IF=20mA	-	3.75	4.2																																	
LED Forward Current	IF	-	-	20	20																																	
ITEM	SYMBOL	CONDITION	MAX.	TYP.	MAX.																																	
LED Input Voltage	VF	IF=20mA	-	3.2	3.5																																	
LED Forward Current	IF	-	-	20	25																																	
7B64PS 2705- TX09D70VM1CDA-2 PAGE 6-1/6	6.1 OPTICAL CHARACTERISTICS OF LCD Revised the color tone																																					

RECORD OF REVISION

DATE	SHEET No.	SUMMARY															
Jan.27,'06	7B64PS 2705- TX09D70VM1CDA-3 PAGE 8-3/6	8.3 POWER ON/OFF SEQUENCE Added the waveform of PCI signal															
	7B64PS 2705- TX09D70VM1CDA-3 PAGE 8-6/6	8.5 INTERNAL PIN CONNECTION Revised the function of PIN35 Revised Note1															
Feb.17,'06	7B64PS 2705- TX09D70VM1CDA-4 PAGE 8-1/6	8.1 INTERFACE TIMING Revised															
		<table border="1" style="display: inline-table; border-collapse: collapse;"> <tr> <td></td> <td style="text-align: center;">MIN</td> <td></td> <td style="text-align: center;">MIN</td> </tr> <tr> <td>Horizontal Total</td> <td style="text-align: center;">258</td> <td rowspan="4" style="text-align: center; vertical-align: middle;">→</td> <td style="text-align: center;">265</td> </tr> <tr> <td>Horizontal Sync Start</td> <td style="text-align: center;">246</td> <td style="text-align: center;">244</td> </tr> <tr> <td>Horizontal Sync End</td> <td style="text-align: center;">250</td> <td style="text-align: center;">248</td> </tr> <tr> <td>Horizontal Blank Time</td> <td style="text-align: center;">18</td> <td style="text-align: center;">25</td> </tr> </table>		MIN		MIN	Horizontal Total	258	→	265	Horizontal Sync Start	246	244	Horizontal Sync End	250	248	Horizontal Blank Time
	MIN		MIN														
Horizontal Total	258	→	265														
Horizontal Sync Start	246		244														
Horizontal Sync End	250		248														
Horizontal Blank Time	18		25														
May.13,'08	7B64PS 2712- TX09D70VM1CDA-5 PAGE 12-1/1	12.1 LOT MARK Changed : 5 digits for production number ↓ 6 digits for production number															
		12.2 Location of lot mark Lot mark change: to Barcode label															
Sep.23,'08	7B64PS 2708- TX09D70VM1CDA - 6 PAGE 8-6/6	8.5 INTERNAL PIN CONNECTION Revised CN1 tyco:1770046-3 (Suitable FPC : t0.3±0.03mm · 0.5±0.03mm pitch) ↓ CN1 : FA5S040HP1R3000 (Suitable FPC : t0.3±0.03mm · 0.5±0.03mm pitch)															
	7B64PS 2712 - TX09D70VM1CDA - 6 PAGE 12 - 1/1	12. DESIGNATION OF LOT MARK Revised REV.A to REV.B															

KAOHSIUNG HITACHI ELECTRONICS CO.,LTD.	DATE	Oct.14,'08	Sh. No.	7B64PS 2702-TX09D70VM1CDA-6	PAGE	2-2/2
---	------	------------	------------	-----------------------------	------	-------

3.GENERAL DATA

The specifications are applied to the following TFT-LCD module (Transmissive with micro reflectance) with Back-light unit.

(1) Part Name	TX09D70VM1CDA
(2) Module Dimensions	64.0(W)mm x 86.0(H)mm x 7.17(D)mm typ.
(3) Effective Display Area	53.64(W)mm x 71.52(H)mm (Diagonal:9cm)
(4) Dot Pitch	0.0745mm x 3(R,G,B)(W) x 0.2235(H)mm
(5) Resolution	240 x 3(R,G,B)(W) x 320 (H) dots
(6) Color Pixel Arrangement	R,G,B Vertical Stripe
(7) LCD Type	Transmissive Color TFT LCD (Normally White)
(8) Display Type	Active Matrix
(9) Number of Colors	262 ^K Colors (R,G,B 6 Bit Digital each)
(10) Backlight	Light Emitting Diode (LED) x 6
(11) Weight	(40)g
(12) Interface	40 pin C-MOS
(13) Power Supply Voltage	3.3V only (Including Timing Controller ,LCD and LED Power Unit)
(14) Viewing Direction	6 O'clock (The direction it's hard to be discolored)

4. ABSOLUTE MAXIMUM RATINGS

4.1 ELECTRICAL ABSOLUTE MAXIMUM RATINGS

VSS=0V

ITEM		SYMBOL	MIN.	MAX.	UNIT	COMMENT
Power Supply for Logic		VDD	-0.3	4.0	V	
Input Voltage		VI	-0.3	VDD+0.3		(Note 1)
Input Current		II	0	1	A	
Static Electricity		VESD0	-	±100	V	(Note 2,3)
		VESD1	-	(8)	kV	(Note 2,4)
LED	Forward Current	IF	-	35	mA	(Note 5)
	Pulse Forward Current	IFP	-	100	mA	(Note 6)
	Reverse Voltage	VR	-	5	V	

Note 1 : DTMG, DCLK, RD0~RD5, GD0~GD5, BD0~BD5.

Note 2 : 200pF-0Ω 25°C -70%RH

Note 3 : Interface Pin Connector.

Note 4 : The surface of metal bezel and LCD panel.

Note 5 :

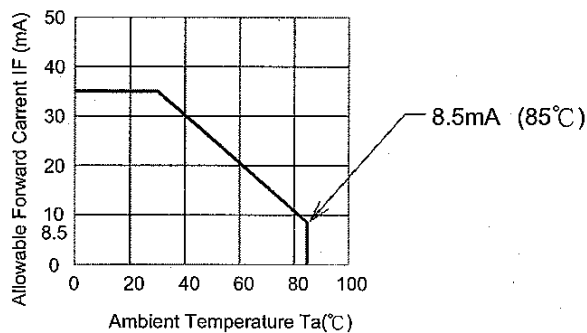

Note 6 : IFP Conditions : pulse width ≤ 10 ms and Duty $\leq 1/10$

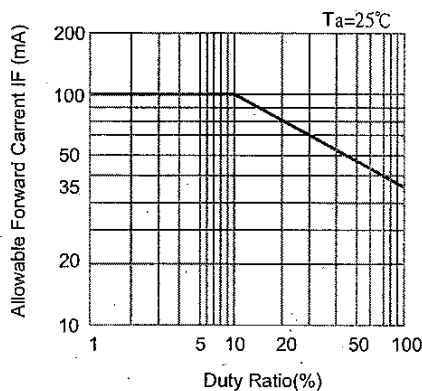

4.2 ENVIRONMENTAL ABSOLUTE MAXIMUM RATINGS

ITEM	OPERATING		STORAGE		REMARKS
	Min.	Max.	Min.	Max.	
Ambient Temperature	-20°C	70°C	-30°C	80°C	(Note 2,3,6,7,9,10)
Humidity	(Note 1)		(Note 1)		Without condensation
Vibration	-	2.45m/s ² (0.25G)	-	11.76m/s ² (1.2G)	(Note 4,5)
Shock	-	29.4m/s ² (3G)	-	490m/s ² (50G)	(Note 5,8)
Corrosive Gas	Not Acceptable		Not Acceptable		

Note 1 : $T_a \leq 40^\circ\text{C}$: 85%RH max.

$T_a > 40^\circ\text{C}$: Absolute humidity must be lower than the humidity of 85%RH at 40°C .

Note 2 : For storage condition T_a at $-30^\circ\text{C} < 48\text{h}$, at $80^\circ\text{C} < 100\text{h}$.

For operating condition T_a at $-20^\circ\text{C} < 100\text{h}$

Note 3 : Background color changes slightly depending on ambient temperature.

This phenomenon is reversible.

Note 4 : 5Hz~100Hz(Except resonance frequency)

Note 5 : This LCM will resume normal operation after finishing the test.

Note 6 : The response time will be slower as low temperature.

Note 7 : Only operation is guaranteed at operating temperature. Contrast, response time, another display quality are evaluated at 25°C .

Note 8 : Pulse Width : 10ms

Note 9 : This is panel surface temperature , not ambient temperature.

Note 10 : If LED is driven by high current, the life time of LED will be reduced, also high temperature and high humidity.

5. ELECTRICAL CHARACTERISTICS

5.1 ELECTRICAL CHARACTERISTICS OF LCD

Ta=25°C, VSS=0V

ITEM	SYMBOL	CONDITION	MIN.	TYP.	MAX.	UNIT
Power Supply Voltage	VDD	-	3.0	3.3	3.6	V
Input voltage for logic (note 1)	VI	"H" level	1.7	-	VDD	V
		"L" level	VSS	-	0.7	
Power Supply Current (note 2)	IDD	VDD-VSS=3.3V	-	200	-	mA
Vsync Frequency	fV	-	52	60	68	Hz
Hsync Frequency	fH	-	10.92	19.5	22.12	kHz
DCLK Frequency	fCLK	-	4.62	5.33	6.04	MHz

Note 1 : DTMG, DCLK, RD0~RD5, GD0~GD5, BD0~BD5.

Note 2 : fV=60Hz, Ta=25°C, Pattern used as display pattern : All Black.

Note 3 : Need to made sure of flickering and rippling of display when setting the frame frequency in your set.

5.2 ELECTRICAL CHARACTERISTICS OF BACK LIGHT

ITEM	SYMBOL	CONDITION	MIN.	TYP.	MAX.	UNIT	REMARKS
LED Input Voltage	VF	IF=20mA	-	3.2	3.5	V	LED / Part
LED Forward Current	IF	-	-	20	25	mA	LED / Part
LED Reverse Current	IR	VR=5V	-	-	50	μA	LED / Part
LED Current Control	Vctrl	VDD-VSS=3.3V	0	1.8	4.0	V	(Note 1)

Note 1 : LED current depend on following conditions .

LED current is calculated by Vctrl and VFB when VFB is controlled by Vctrl.

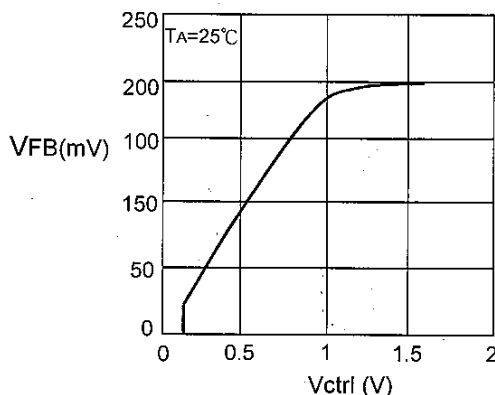

$$I_{LED} : \frac{V_{FB}}{10} : \text{When } V_{ctrl} > 1.8 \text{ V.}$$

$$I_{LED} : \frac{V_{ctrl}}{50} : \text{When } V_{ctrl} < 1 \text{ V.}$$

6. OPTICAL CHARACTERISTICS

6.1 OPTICAL CHARACTERISTICS OF LCD (BACK LIGHT ON)

Ta=25°C

ITEM	SYMBOL	CONDITION	MIN.	TYP.	MAX.	UNIT	NOTE	
Brightness	B	$\phi=0^\circ \theta=0^\circ$	-	400	-	cd/m ²	(1)	
Uniformity	-	$\phi=0^\circ \theta=0^\circ$	70	-	-	%	(2),(3),(4)	
Viewing Angle	θx	$\phi=0^\circ, K \geq 5.0$	-	60	-	deg	(5),(6)	
	$\theta x'$	$\phi=180^\circ, K \geq 5.0$	-	80	-			
	θy	$\phi=90^\circ, K \geq 5.0$	-	70	-			
	$\theta y'$	$\phi=270^\circ, K \geq 5.0$	-	70	-			
Contrast Ratio	K	$\phi=0^\circ \theta=0^\circ$	180	300	-	-	(4)	
Response Time (rise-fall)	tr+tf	$\phi=0^\circ \theta=0^\circ$	-	(30)	-	ms	(8)	
Color Tone (Primary Color)	Red	x	$\phi=0^\circ \theta=0^\circ$	0.55	0.60	0.65	-	(4)
		y		0.29	0.34	0.39	-	
	Green	x		0.28	0.33	0.38	-	
		y		0.54	0.59	0.64	-	
	Blue	x		0.09	0.14	0.19	-	
		y		0.07	0.12	0.17	-	
	White	x		0.27	0.32	0.37	-	
		y		0.29	0.34	0.39	-	

(Measurement condition : HITACHI standard)

Note 1 : Active area center

Note (4)~(7) : See page 6-2/2

Note 2 : Driving Condition

Display Pattern : White Raster

LED Current : 20mA / Part

Measurement of the following

5 places on the display.

Note 3 : Definition of the brightness uniformity

$$\left(\frac{\text{Min. brightness}}{\text{Max. brightness}} \right) \times 100$$

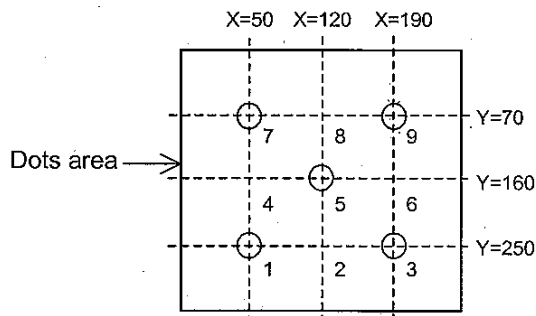

Note 4 : Measurement Condition

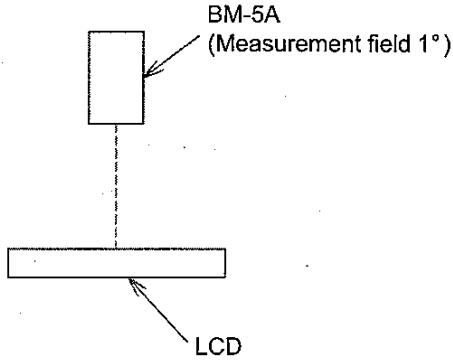

Note 5 : Definition of θ and ϕ
(Normal)
Viewing direction

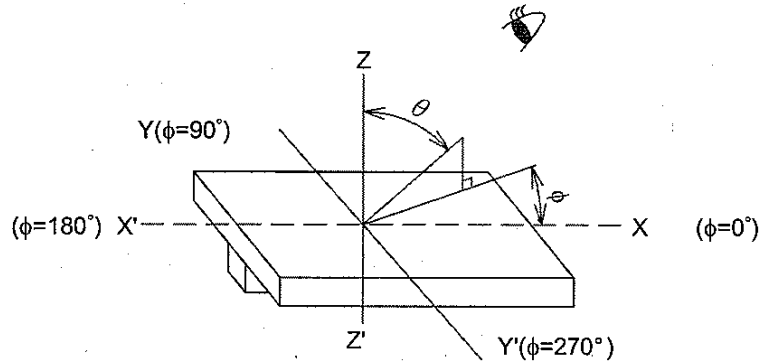

Note 6 : Definition of Viewing angle

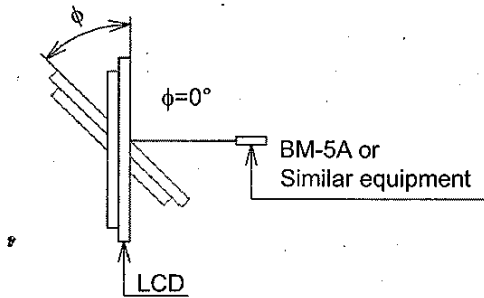

Note 7 : Definition of contrast "K"

$$K = \frac{\text{White Brightness}}{\text{Black Brightness}}$$

Note 8 : Definition optical response time

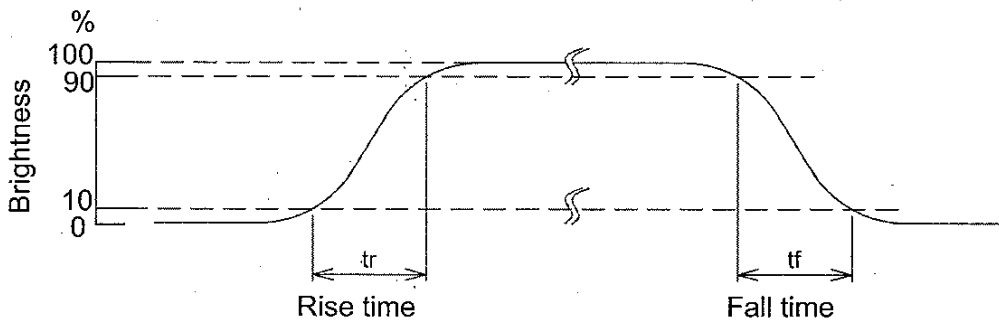
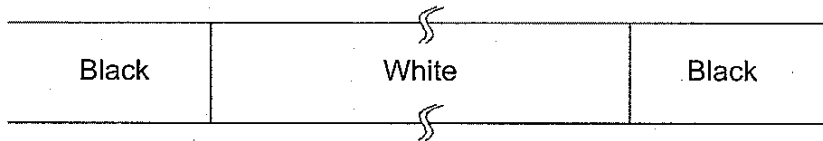

7.BLOCK DIAGRAM

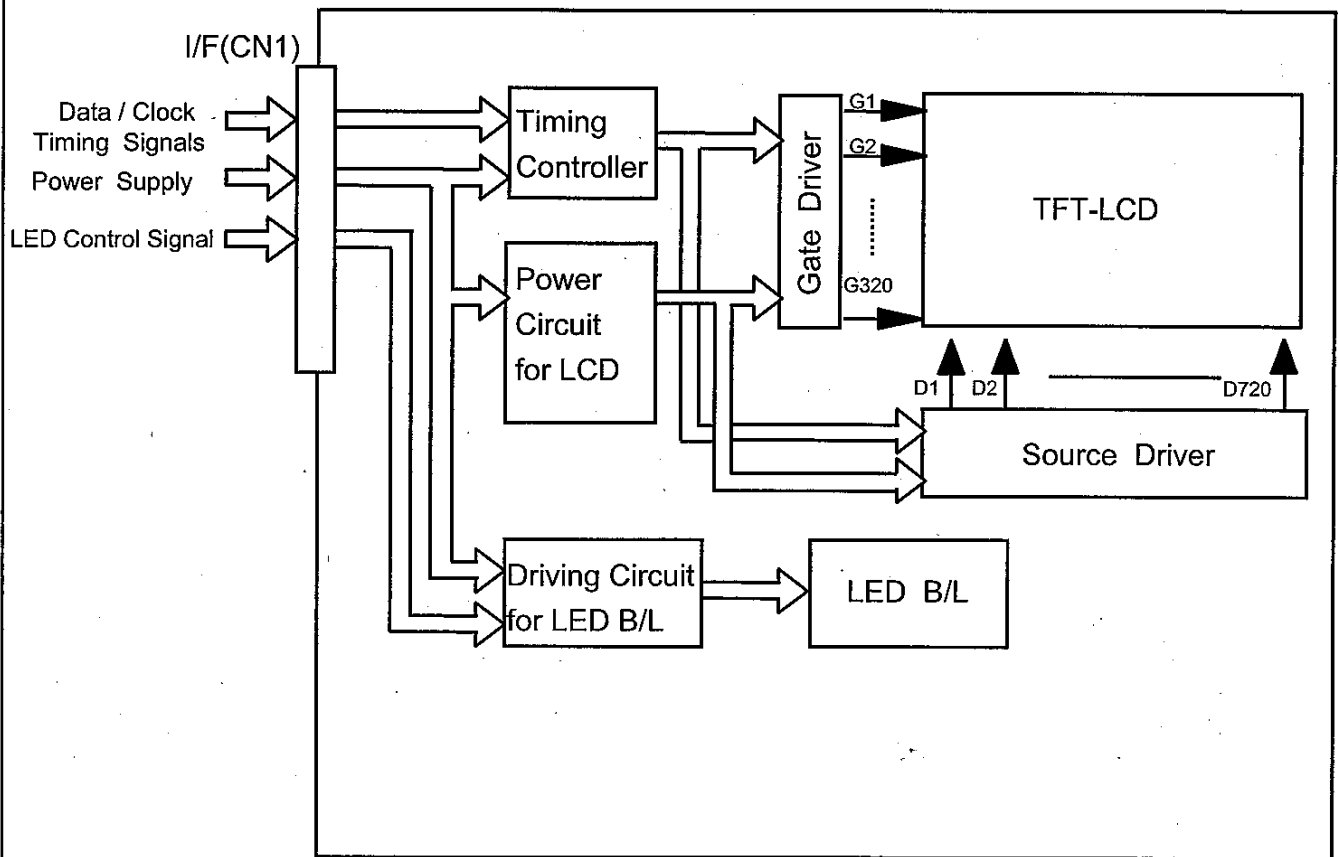

Downloaded from Elcodis.com electronic components distributor

8. INTERFACE TIMING

8.1 INTERFACE TIMING

	MIN.	TYP.	MAX.	UNIT	SYMBOL
Vertical Total	-	327	-	Line	T0
Vertical Sync Width	1	1	-	Line	T1
Vertical Sync Start	-	322	-	Line	T2
Vertical Sync End	-	323	-	Line	T3
Vertical Blank Time	5	7	-	Line	T4
Vertical Display End	-	320	-	Line	T5
Horizontal Total	265	273	509	Pixel Clock	T6
Horizontal Sync Width	4	5	10	Pixel Clock	T7
Horizontal Sync Start	244	251	307	Pixel Clock	T8
Horizontal Sync End	248	256	317	Pixel Clock	T9
Horizontal Blank Time	25	33	269	Pixel Clock	T10
Horizontal Display End	-	240	-	Pixel Clock	T11

Note : Vertical Total should be set to odd.

8.2 TIMING CHART

(Data is latched negative edge trigger of DCLK)

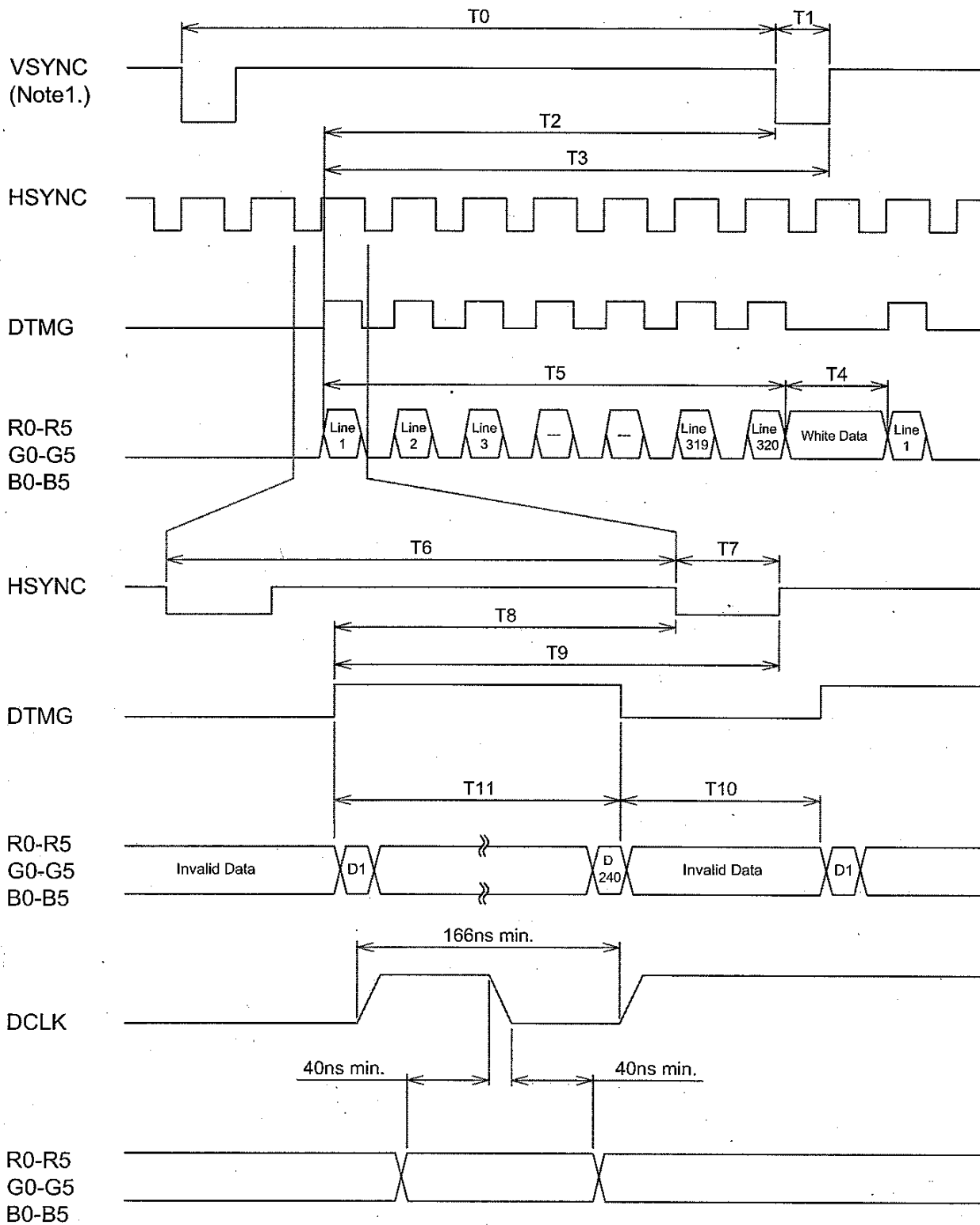
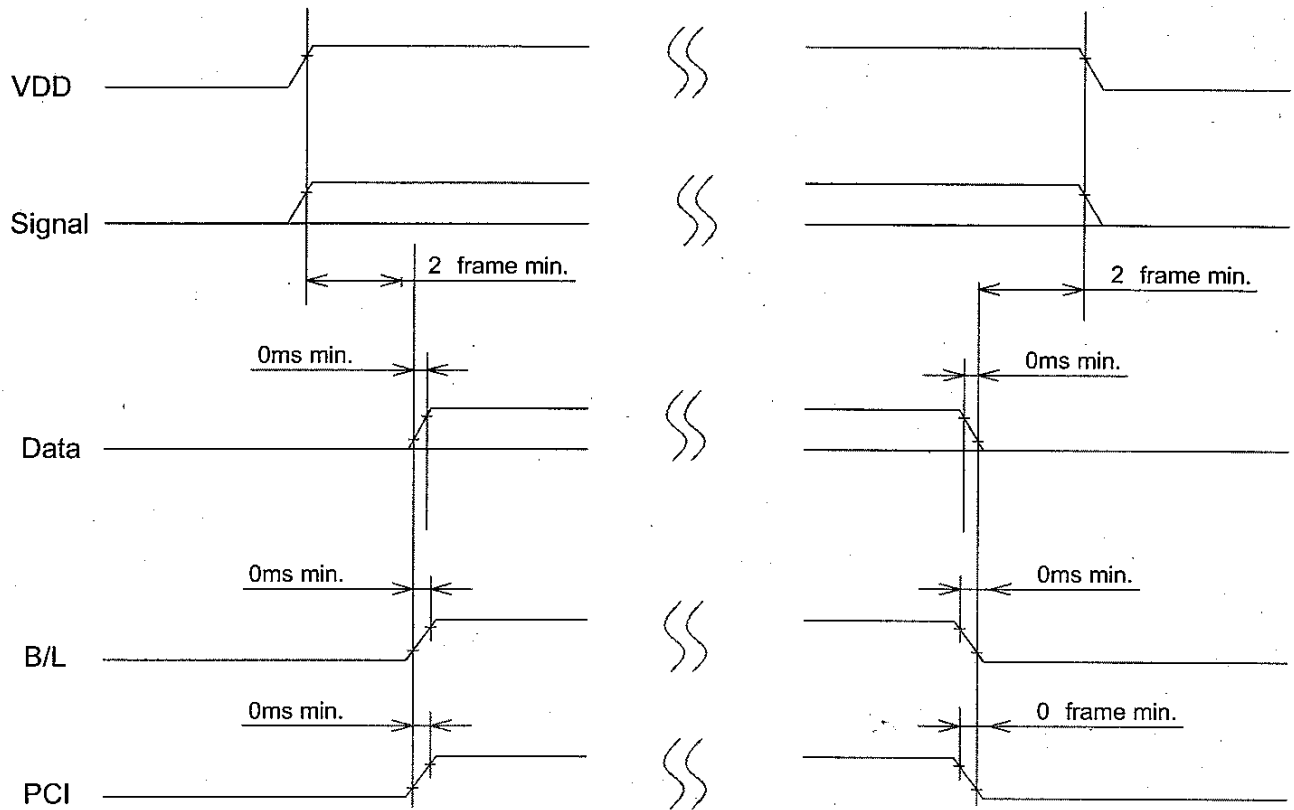

Fig1. Timing sequence for Graphic controller

Note1. VSYNC is generated by Tcon IC.

8.3 POWER ON/OFF SEQUENCE



NOTE :

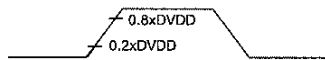

8.4 RELATIONSHIP BETWEEN DISPLAYED COLOR AND INPUT DATA

8.4.1 Display Colors

color	Input	Red Data						Green Data						Blue Data					
		R5	R4	R3	R2	R1	R0	G5	G4	G3	G2	G1	G0	B5	B4	B3	B2	B1	B0
		MSB			LSB			MSB			LSB			MSB			LSB		
Basic Color	Black	0	0	0	0	0	0	0	0	0	0	0	0	0	0	0	0	0	0
	Red(0)	1	1	1	1	1	1	0	0	0	0	0	0	0	0	0	0	0	0
	Green(0)	0	0	0	0	0	0	1	1	1	1	1	1	0	0	0	0	0	0
	Blue(0)	0	0	0	0	0	0	0	0	0	0	0	0	1	1	1	1	1	1
	Cyan	0	0	0	0	0	0	1	1	1	1	1	1	1	1	1	1	1	1
	Magenta	1	1	1	1	1	1	0	0	0	0	0	0	1	1	1	1	1	1
	Yellow	1	1	1	1	1	1	1	1	1	1	1	1	0	0	0	0	0	0
	White	1	1	1	1	1	1	1	1	1	1	1	1	1	1	1	1	1	1
Red	Black	0	0	0	0	0	0	0	0	0	0	0	0	0	0	0	0	0	0
	Red(62)	0	0	0	0	0	1	0	0	0	0	0	0	0	0	0	0	0	0
	Red(61)	0	0	0	0	1	0	0	0	0	0	0	0	0	0	0	0	0	0
	:	:	:	:	:	:	:	:	:	:	:	:	:	:	:	:	:	:	:
	:	:	:	:	:	:	:	:	:	:	:	:	:	:	:	:	:	:	:
	Red(2)	1	1	1	1	0	1	0	0	0	0	0	0	0	0	0	0	0	0
	Red(1)	1	1	1	1	1	0	0	0	0	0	0	0	0	0	0	0	0	0
	Red(0)	1	1	1	1	1	1	0	0	0	0	0	0	0	0	0	0	0	0
Green	Black	0	0	0	0	0	0	0	0	0	0	0	0	0	0	0	0	0	0
	Green(62)	0	0	0	0	0	0	0	0	0	0	0	1	0	0	0	0	0	0
	Green(61)	0	0	0	0	0	0	0	0	0	0	1	0	0	0	0	0	0	
	:	:	:	:	:	:	:	:	:	:	:	:	:	:	:	:	:	:	:
	:	:	:	:	:	:	:	:	:	:	:	:	:	:	:	:	:	:	:
	Green(2)	0	0	0	0	0	0	1	1	1	1	0	1	0	0	0	0	0	0
	Green(1)	0	0	0	0	0	0	1	1	1	1	1	0	0	0	0	0	0	0
	Green(0)	0	0	0	0	0	0	1	1	1	1	1	1	0	0	0	0	0	0
Blue	Black	0	0	0	0	0	0	0	0	0	0	0	0	0	0	0	0	0	0
	Blue(62)	0	0	0	0	0	0	0	0	0	0	0	0	0	0	0	0	0	1
	Blue(61)	0	0	0	0	0	0	0	0	0	0	0	0	0	0	0	0	1	0
	:	:	:	:	:	:	:	:	:	:	:	:	:	:	:	:	:	:	:
	:	:	:	:	:	:	:	:	:	:	:	:	:	:	:	:	:	:	:
	Blue(2)	0	0	0	0	0	0	0	0	0	0	0	0	1	1	1	1	0	1
	Blue(1)	0	0	0	0	0	0	0	0	0	0	0	0	1	1	1	1	1	0
	Blue(0)	0	0	0	0	0	0	0	0	0	0	0	0	1	1	1	1	1	1

8.5 INTERNAL PIN CONNECTION

CN1 : FA5S040HP1R3000 (Suitable FPC : t0.3±0.03mm · 0.5±0.03mm pitch)

PIN No.	SIGNAL	FUNCTION
1	VDD	Power Supply for Logic
2	VDD	Power Supply for Logic
3	VDD	Power Supply for Logic
4	DCLK	Dot Clock
5	VSS	GND
6	HSYNC	Horizontal Sync Pulse
7	VSS	GND
8	DTMG	Timing Signal for Data
9	VSS	GND
10	NC	No Connection
11	VSS	GND
12	R5	Red Data
13	R4	
14	R3	
15	VSS	GND
16	R2	Red Data
17	R1	
18	R0	
19	VSS	GND
20	G5	Green Data
21	G4	
22	G3	
23	VSS	GND
24	G2	Green Data
25	G1	
26	G0	
27	VSS	GND
28	B5	Blue Data
29	B4	
30	B3	
31	VSS	GND
32	B2	Blue Data
33	B1	
34	B0	
35	PCI	Power Control In (Note1)
36	Vctrl	LED Current Control
37	NC	No Connection
38	NC	No Connection
39	NC	No Connection
40	NC	No Connection

Note 1. Please follow the page 8-3/6 to set the PCI.

9. DIMENSIONAL OUTLINE

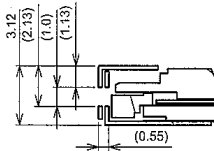
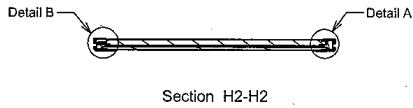
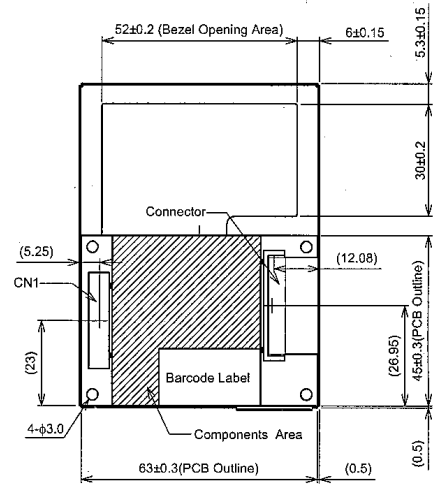
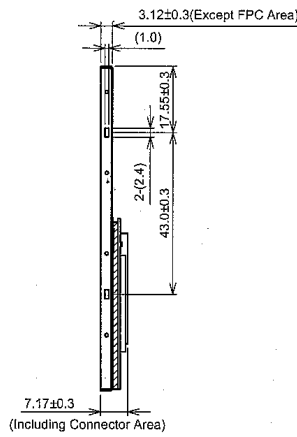
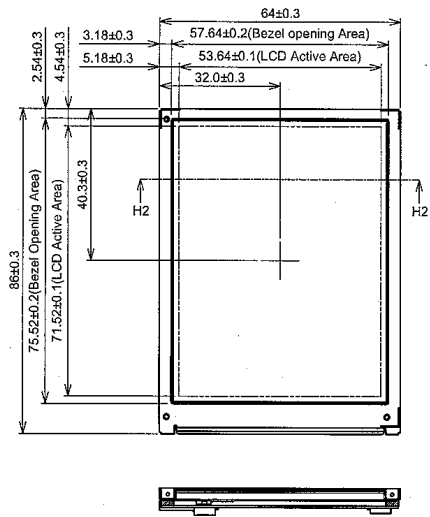

Detail B
Scale 5:1

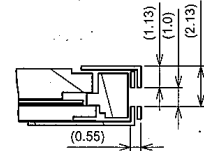

Detail A
Scale 5:1

Scale : NTS
Unit : mm

KAOSIUNG HITACHI ELECTRONICS CO.,LTD.	DATE	Oct.14,'08	Sh. No.	7B64PS 2709-TX09D70VM1CDA-6	PAGE	9-1/1
--	------	------------	------------	-----------------------------	------	-------

10. APPEARANCE STANDARD

10.1 APPEARANCE INSPECTION CONDITION

Visual inspection should be done under the following condition.

- (1) The inspection should be done in a dark room.(More than 1000(lx) and non-directive)
- (2) The distance between eyes of an inspector and the LCD module is 30cm.
- (3) The viewing zone is shown the figure.

Viewing angle $\leq 25^\circ$

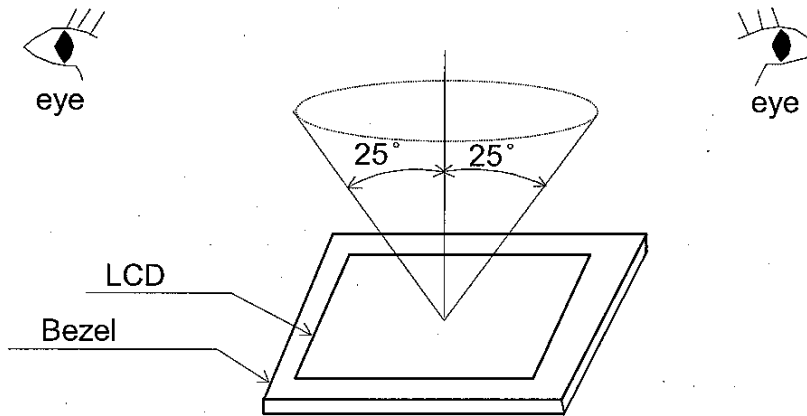

10.2 DEFINITION OF ZONE

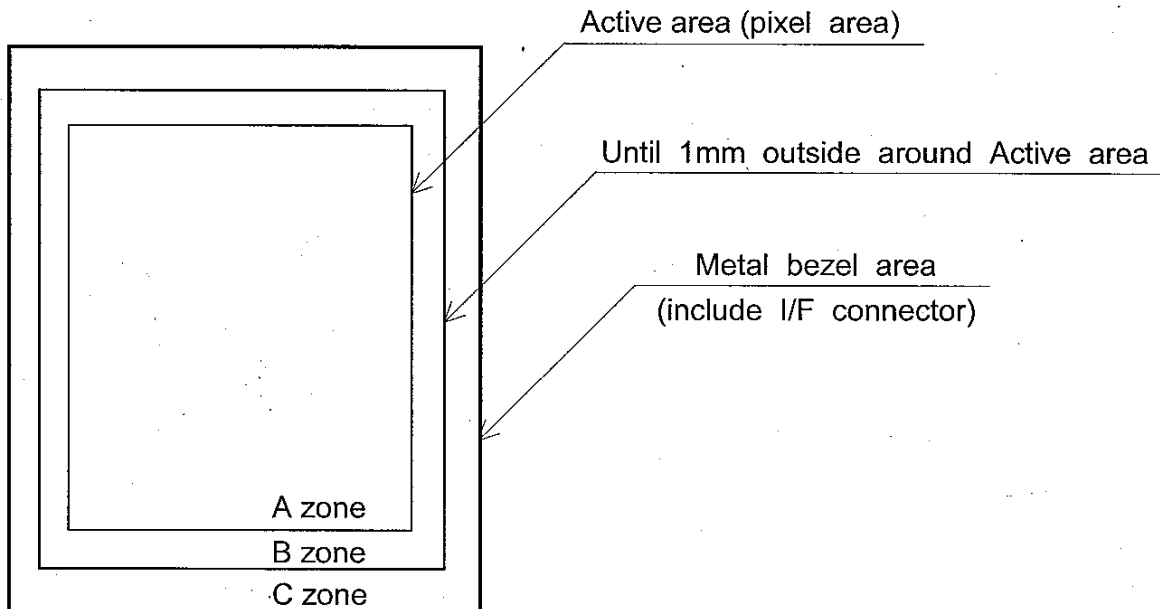

10.3 APPEARANCE SPECIFICATION

(1) LCD Appearance

*) If the problem related to this section occurs about this item, the responsible persons of both party (Customer and HITACHI) will discuss the matter in detail.

No.	ITEM	CRITERIA			APPLIED ZONE
L C D	Scratches	Length L(mm)	Width W(mm)	Maximum number acceptable	A,B
		$L \leq 2.0$	$W \leq 0.03$	ignored	
		$L \leq 2.0$	$0.03 < W \leq 0.05$	4	
		$L > 2.0$	$0.05 < W$	none	
	Dent	Distinguished one is acceptable (To be judged by HITACHI standard)			A
	Wrinkles in Polarizer	Same as above			A
	Bubbles	Average diameter D(mm)		Maximum number acceptable	A
		$D \leq 0.3$		2	
		$0.3 < D$		none	
	Stains Foreign Materials	Filamentous (Line shape)			A,B
		Length L(mm)	Width W(mm)	Maximum number acceptable	
		$L < 2.0$	$W \leq 0.05$	4	
	Dark spot	$L \leq 1.0$ $0.05 < W \leq 0.1$			2
		Round(Dot shape)			A,B
		Average diameter D(mm)		Maximum number acceptable	
		$D \leq 0.15$		6	
		$0.15 < D \leq 0.2$		4	
		$0.2 < D$		none	
		The total number		Filamentous + Round=9	
	Those wiped out easily are acceptable				
Color Tone	To be judged by HITACHI STANDARD			A	
Color Uniformity	Same as above			A	
Dot Defect			Maximum number acceptable	A, B	
	Sparkle mode	1 dot	4		
		2 dots	2(sets)		
		Total	4		
	Black mode	1 dot	4		
		2 dots	2(sets)		
		Total	4		
Sparkle mode & Black mode	2 dots	2(sets)			
	Total	6			

Note 1 : Definition of average diameter (D)

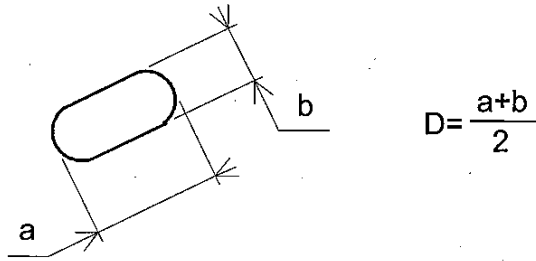

Note 2 : Definition of length (L) and width (W)

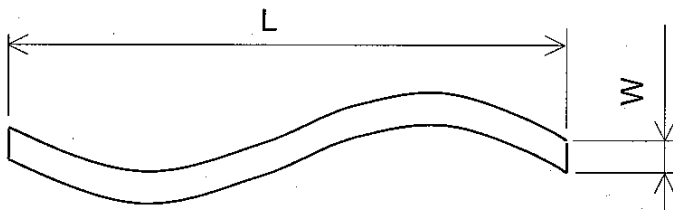

Note 3 : Definition of dot defect

- (a) Dot Defect : Defect Area > 1/2 dot
- (b) Sparkle mode : Brightness of dot is more than 30% at Black raster.
- (c) Black mode : Brightness of dot is less than 70% at R.G.B raster.
- (d) 1 dot : Defect dot is isolated , not attached to other defect dot.
- (e) N dot : N defect dots are consecutive .

(N means the number of defect dots.)

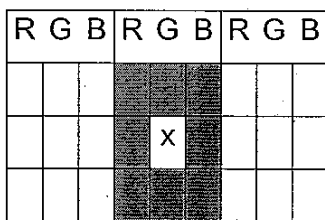

2 dots defect included defect dot "X" is defined as follows.

Adjacent dots to defect dot "X" :

- (f) Counting definition of adjacent dots(1 sets) : same as 1 dot defect.
- (g) Those wiped out easily are acceptable

11. PRECAUTION IN DESIGN

11.1 PRECAUTIONS AGAINST ELECTROSTATIC DISCHARGE

As this module contains C-MOS LSIs, it is not strong against electrostatic discharge. Make certain that the operator's body is connected to the ground through a wrist band, etc.

And don't touch I/F pins directly.

11.2 HANDLING PRECAUTIONS

- (1) As the adhesives used for adhering upper/lower polarizer's and frame are made of organic substances which will be deteriorated by a chemical reaction with such chemicals as acetone, toluene, ethanol and isopropyl alcohol. The following are recommended for use:

normal hexane

Please contact with us when it is necessary for you to use chemicals other than the above.

- (2) Lightly wipe to clean the dirty surface with absorbent cotton or other soft material like chamois, soaked in the recommended chemicals without scrubbing it hardly.

Always wipe the surface horizontally or vertically. Never give a wipe in a circle. To prevent the display surface from damage and keep the appearance in good state, it is sufficient, in general, to wipe it with absorbent cotton.

- (3) Immediately wipe off saliva or water drop attached on the display area because it may cause deformation or faded color.

- (4) Foggy dew deposited on the surface may cause a damage, stain or dirt to the polarizer.

When you need to take out the LCD module from some place at low temperature for test, etc.

It is required to be warmed them up to temperature higher than room temperature before taking them out.

- (5) Touching the display area or I/F pins with bare hands or contaminating them are prohibited, because the stain on the display area and poor insulation between terminals are often caused by being touched with bare hands.

(Some cosmetics are detrimental to polarizer's.)

- (6) In general, the glass is fragile so that, especially on its periphery, tends to be cracked or chipped in handling. Please not give the LCD module sharp shocks by falling, etc.

- (7) Maximum pressure to the surface must be less than 1.96×10^4 Pa.

And if the pressure area is less than 1cm^2 , maximum pressure must be less than 1.96N.

- (8) Since the metal width is narrow on these locations (see page 9-1/1), please careful with handling.

KAOHSIUNG HITACHI ELECTRONICS CO.,LTD.	DATE	Oct.14,'08	Sh. No.	7B64PS 2711-TX09D70VM1CDA-6	PAGE	11-1/2
---	------	------------	------------	-----------------------------	------	--------

- (9) Top sheets shall be cleaned gently using a soft cloth such as those used for glasses.
Hard wiping accumulated dust will leave scars on the surface even using a cloth.

11.3 OPERATION PRECAUTION

- (1) Using a LCM module beyond its maximum ratings may result in its permanent destruction.
LCM module's should usually be used under recommended operating conditions shown in chapter 4. Exceeding any of these conditions may adversely affect its reliability.
- (2) Response time will be extremely delayed at lower temperature than the specified operating temperature range and on the other hand LCD's shows dark blue at higher temperature.
However those phenomena do not main defects of the LCD module. Those phenomena will disappear in the specified operating temperature range.
- (3) If the display area is pushed hard during operation, some display patterns will be abnormally display.
- (4) A slight dew depositing on terminals may cause electrochemical reaction which leads to terminal open circuit. Please operate the LCD module under the relative condition of 40°C 85%RH.

11.4 STORAGE

In case of storing LCD module for a long period of time (for instance, for years) for the purpose of replacement use, the following precautions necessary.

- (1) Store the LCD modules in a dark place; do not expose them to sunlight or ultraviolet rays.
- (2) Keep the temperature between -30°C and 80°C at normal humidity.
- (3) Store the LCD modules in the container which is used for shipping from us.
- (4) No articles shall be left on the surface over an extended period of time.

12. DESIGNATION OF LOT MARK

12.1 LOT MARK

Lot mark is consisted of 4 digits for production lot and 6 digits for production control.

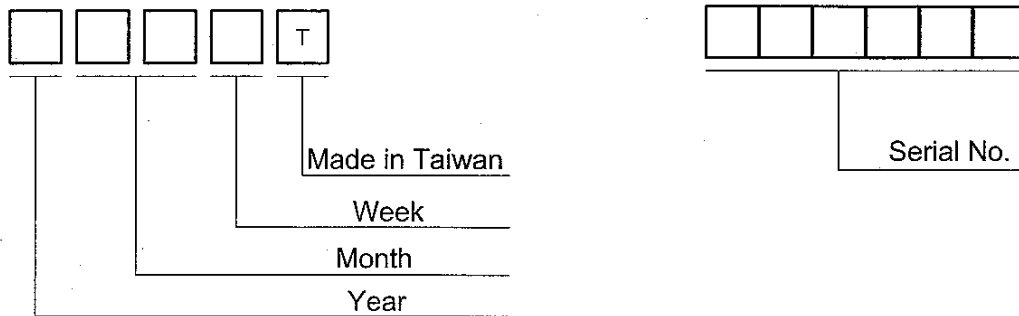

Year	Mark
2008	8
2009	9
2010	0
2011	1
2012	2

Month	Jan.	Feb.	Mar.	Apr.	May	Jun.
Mark	01	02	03	04	05	06
Month	Jul.	Aug.	Sep.	Oct.	Nov.	Dec.
Mark	07	08	09	10	11	12

Week (Day In Calendar)	Figure In Lot Mark
01~07	1
08~14	2
15~21	3
22~28	4
29~31	5

12.2 SERIAL No.

Serial No. is consisted of 6 digits number (000001~999999).

12.3 REVISION (REV.) CONTROL

Rev. is the column for manufacturing convenience A-Z except I and O maybe written on this column.

12.4 LOCATION OF LABEL : On the PCB

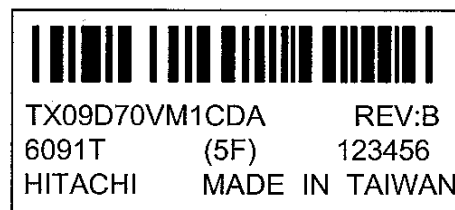
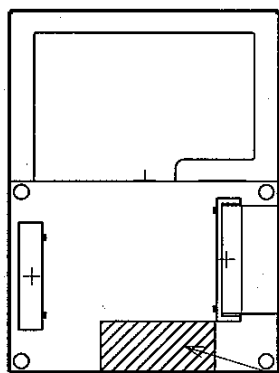

Label

REV.	Item
A	-
B	1.Changed DC/DC converter circuit design. 2.Barcode label.

13. PRECAUTION FOR USE

(1) A limit sample should be provided by the both parties on an occasion when the both parties agree to its necessity.

Judgement by a limit sample shall take effect after the limit sample has been established and confirmed by the both parties.

(2) On the following occasions, the handling of the problem should be decided through discussion and agreement between responsible persons of the both parties.

1) When a question is arisen in the specifications.

2) When a new problem is arisen which is not specified in this specifications.

3) When an inspection specifications change or operating condition change by customer is reported to HITACHI, and some problem is arisen in the specification due to the change.

4) When a new problem is arisen at the customer's operating set for sample evaluation.

(3) Regarding the treatment for maintenance and repairing, both parties will discuss it in six months later after latest delivery of this product.

The precaution that should be observed when handling LCM have been explained above.

If any points are unclear or if you have any requests, please contact with HITACHI.