

3130/3134/3151

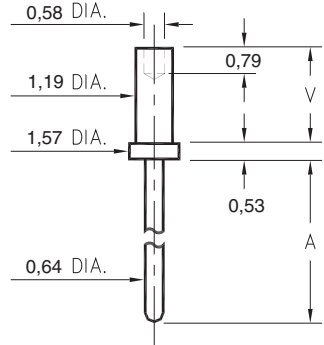

Basic Part Number	Board Thickness	Length A	Length V
3134-1	0,79	2,01	1,30
3134-2	1,57	2,01	2,08
3134-3	2,39	2,01	2,87
3134-4	3,18	2,01	3,68
3130-1	0,79	4,55	1,30
3130-2	1,57	4,55	2,08
3130-3	2,39	4,55	2,87
3130-4	3,18	4,55	3,68
3151-1	0,79	12,17	1,30
3151-2	1,57	12,17	2,08
3151-3	2,39	12,17	2,87
3151-4	3,18	12,17	3,68

31XX-X-00-XX-00-00-08-0
Swage mount in 1,32 hole

3113

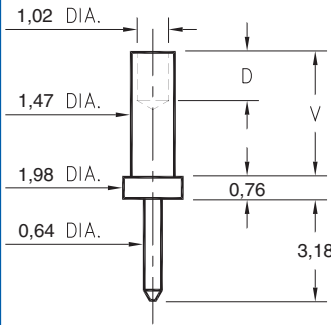

Basic Part Number	Board Thickness	Length V	Depth D
3113-1	0,79	1,57	1,02
3113-2	1,57	2,39	1,57
3113-3	2,39	3,18	1,57
3113-4	3,18	3,96	1,57

3113-X-00-XX-00-00-08-0
Swage mount in 1,57 hole

3360

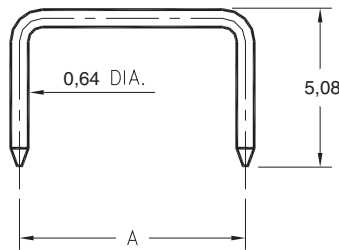

Basic Part Number	Pin Centers A
3360-1	5,08
3360-2	6,35
3360-3	7,62
3360-4	10,16
3360-5	12,7

3360-X-14-XX-00-00-08-0
Shorting Jumper

3301 → 3304

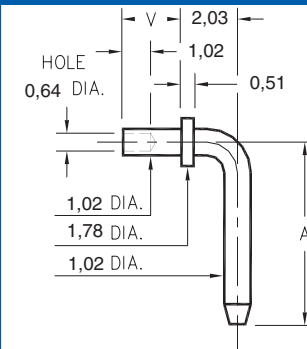

Basic Part Number	Pin Centers A
3301-X	6,53
3302-X	9,07
3303-X	9,53
3304-X	14,27

- X -	Board Thickness	Length V
1	0,79	1,30
2	1,57	2,08
3	2,39	2,87

330X-X-14-XX-00-00-08-0
Specify board thickness
Swage mount in 1,09 hole

3620

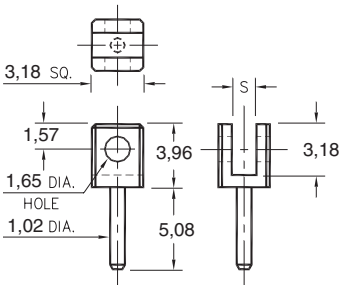

Basic Part Number	Board Thickness	Slot S
3620-1	0,79	1,19
3620-2	1,57	1,91

3620-X-32-XX-00-00-08-0
Board edge rivet mount

0940

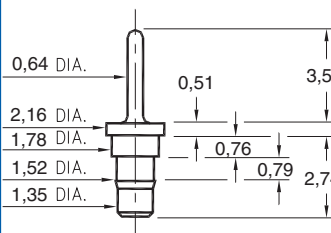

0940-0-00-XX-00-00-03-0
Press-fit in 1,45 mounting hole

3621

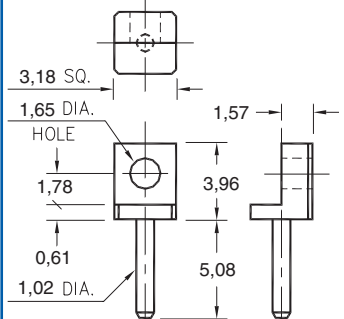

3621-0-32-XX-00-00-08-0
Board edge rivet mount

SPECIFICATIONS

PIN MATERIAL:
Brass Alloy 360, 1/2 Hard
(Except Swage pins which are annealed)

PART MANUFACTURED IN INCHES, METRIC FOR REF ONLY

TOLERANCES ON:
LENGTHS: ± 0,13
DIAMETERS: ± 0,05
ANGLES: ± 2°

ORDER CODE: XXXX - X - XX - XX - 00 - 00 - 0X - 0

BASIC PART #

SPECIFY PIN FINISH:

- 01 5,08µm TIN/LEAD OVER NICKEL
- 80 5,08µm TIN OVER NICKEL
- 15 0,25µm GOLD OVER NICKEL
- 21 0,51µm GOLD OVER NICKEL
- 34 1,27µm GOLD OVER NICKEL

