

ISAC-SX TE

ISDN Subscriber Access
Controller for Terminals

PSB 3186, V 1.4

Wired
Communications



Never stop thinking.

ABM[®], ACE[®], AOP[®], ARCOFI[®], ASM[®], ASP[®], DigiTape[®], DuSLIC[®], EPIC[®], ELIC[®], FALC[®], GEMINAX[®], IDEC[®], INCA[®], IOM[®], IPAT[®]-2, ISAC[®], ITAC[®], IWE[®], IWORX[®], MUSAC[®], MuSLIC[®], OCTAT[®], OptiPort[®], POTSWIRE[®], QUAT[®], QuadFALC[®], SCOUT[®], SICAT[®], SICOFI[®], SIDEC[®], SLICOFI[®], SMINT[®], SOCRATES[®], VINETIC[®], 10BaseV[®], 10BaseVX[®] are registered trademarks of Infineon Technologies AG. 10BaseS[™], EasyPort[™], VDSLite[™] are trademarks of Infineon Technologies AG. Microsoft[®] is a registered trademark of Microsoft Corporation. Linux[®] is a registered trademark of Linus Torvalds.

The information in this document is subject to change without notice.

Edition 2003-01-30

**Published by Infineon Technologies AG,
St.-Martin-Strasse 53,
81669 München, Germany**

**© Infineon Technologies AG 2003.
All Rights Reserved.**

Attention please!

The information herein is given to describe certain components and shall not be considered as warranted characteristics.

Terms of delivery and rights to technical change reserved.

We hereby disclaim any and all warranties, including but not limited to warranties of non-infringement, regarding circuits, descriptions and charts stated herein.

Infineon Technologies is an approved CECC manufacturer.

Information

For further information on technology, delivery terms and conditions and prices please contact your nearest Infineon Technologies Office in Germany or our Infineon Technologies Representatives worldwide (www.infineon.com).

Warnings

Due to technical requirements components may contain dangerous substances. For information on the types in question please contact your nearest Infineon Technologies Office.

Infineon Technologies Components may only be used in life-support devices or systems with the express written approval of Infineon Technologies, if a failure of such components can reasonably be expected to cause the failure of that life-support device or system, or to affect the safety or effectiveness of that device or system. Life support devices or systems are intended to be implanted in the human body, or to support and/or maintain and sustain and/or protect human life. If they fail, it is reasonable to assume that the health of the user or other persons may be endangered.

Data Sheet**Revision History: 2003-01-30**

DS1

Previous Version: Data Sheet, DS1, V1.3, 2000-08-23

Page	Subjects (major changes since last revision)
Chapter 1	Comparison ISAC-S TE/ISAC-SX TE
Chapter 3.3.6.2	S- Transceiver Synchronization New
Chapter 3.3.10	Test Functions extended
Chapter 3.7.1.1	CDA Handler Description extended
Chapter 3.7.5.1	TIC Bus Access Control: Note added
Chapter 5.6	IOM-2 Interface Timing: Explanation added
Chapter 5.7.2	Parallel Microcontroller Interface Timing: Explanation added
Chapter 5.9	S-Transceiver
Chapter 5.10	Recommended Transformer Specification: Changed
Chapter 5.11	Line Overload Protection added
Chapter 5.12	EMC/ESD added

Table of Contents		Page
1	Overview	12
1.1	Features	15
1.2	Logic Symbol	17
1.3	Typical Applications	18
2	Pin Configuration	19
3	Description of Functional Blocks	25
3.1	General Functions and Device Architecture	25
3.2	Microcontroller Interfaces	27
3.2.1	Serial Control Interface (SCI)	28
3.2.1.1	Programming Sequences	29
3.2.2	Parallel Microcontroller Interface	31
3.2.3	Interrupt Structure	33
3.2.4	Reset Generation	34
3.2.5	Timer Modes	35
3.2.6	Activation Indication via Pin ACL	38
3.3	S/T-Interface	39
3.3.1	S/T-Interface Coding	40
3.3.2	S/T-Interface Multiframeing	42
3.3.3	Data Transfer and Delay between IOM-2 and S/T	44
3.3.4	Transmitter Characteristics	45
3.3.5	Receiver Characteristics	46
3.3.6	S/T Interface Circuitry	47
3.3.6.1	External Protection Circuitry	47
3.3.6.2	S-Transceiver Synchronization	50
3.3.7	S/T Interface Delay Compensation	50
3.3.8	Level Detection Power Down	50
3.3.9	Transceiver Enable/Disable	51
3.3.10	Test Functions	52
3.4	Clock Generation	54
3.4.1	Description of the Receive PLL (DPLL)	55
3.4.2	Jitter	55
3.4.3	Oscillator Clock Output C768	56
3.5	Control of Layer-1	57
3.5.1	State Machine TE Mode	59
3.5.1.1	State Transition Diagram (TE)	59
3.5.1.2	States (TE)	61
3.5.1.3	C/I Codes (TE)	63
3.5.1.4	Infos on S/T (TE)	65
3.5.2	Command/ Indicate Channel Codes (C/I0) - Overview	66
3.6	Control Procedures	67
3.6.1	Example of Activation/Deactivation	67

Table of Contents		Page
3.7	IOM-2 Interface	68
3.7.1	IOM-2 Handler	70
3.7.1.1	Controller Data Access (CDA)	72
3.7.2	Serial Data Strobe Signal and Strobed Data Clock	82
3.7.2.1	Serial Data Strobe Signal	82
3.7.2.2	Strobed IOM-2 Bit Clock	84
3.7.3	IOM-2 Monitor Channel	84
3.7.3.1	Handshake Procedure	86
3.7.3.2	Error Treatment	89
3.7.3.3	MONITOR Channel Programming as a Master Device	91
3.7.3.4	MONITOR Channel Programming as a Slave Device	91
3.7.3.5	Monitor Time-Out Procedure	92
3.7.3.6	MONITOR Interrupt Logic	93
3.7.4	C/I Channel Handling	93
3.7.5	D-Channel Access Control	95
3.7.5.1	TIC Bus D-Channel Access Control	95
3.7.5.2	S-Bus Priority Mechanism for D-Channel	97
3.7.6	Activation/Deactivation of IOM-2 Interface	100
3.8	HDLC Controller	102
3.8.1	Message Transfer Modes	102
3.8.2	Data Reception	104
3.8.2.1	Structure and Control of the Receive FIFO	104
3.8.2.2	Receive Frame Structure	109
3.8.3	Data Transmission	112
3.8.3.1	Structure and Control of the Transmit FIFO	112
3.8.3.2	Transmit Frame Structure	116
3.8.4	Access to IOM-2 Channels	117
3.8.5	Extended Transparent Mode	117
3.8.6	HDLC Controller Interrupts	118
3.9	Test Functions	119
4	Detailed Register Description	121
4.1	D-channel HDLC Control and C/I Registers	128
4.1.1	RFIFOD - Receive FIFO D-Channel	128
4.1.2	XFIFOD - Transmit FIFO D-Channel	128
4.1.3	ISTAD - Interrupt Status Register D-Channel	128
4.1.4	MASKD - Mask Register D-Channel	130
4.1.5	STARD - Status Register D-Channel	130
4.1.6	CMDRD - Command Register D-channel	131
4.1.7	MODED - Mode Register	132
4.1.8	EXMD1- Extended Mode Register D-channel 1	134
4.1.9	TIMR1 - Timer 1 Register	135
4.1.10	SAP1 - SAPI1 Register	135

Table of Contents		Page
4.1.11	SAP2 - SAPI2 Register	136
4.1.12	RBCLD - Receive Frame Byte Count Low D-Channel	136
4.1.13	RBCHD - Receive Frame Byte Count High D-Channel	137
4.1.14	TEI1 - TEI1 Register 1	137
4.1.15	TEI2 - TEI2 Register	138
4.1.16	RSTAD - Receive Status Register D-Channel	138
4.1.17	TMD -Test Mode Register D-Channel	140
4.1.18	CIR0 - Command/Indication Receive 0	140
4.1.19	CIX0 - Command/Indication Transmit 0	141
4.1.20	CIR1 - Command/Indication Receive 1	142
4.1.21	CIX1 - Command/Indication Transmit 1	142
4.2	Transceiver Registers	144
4.2.1	TR_CONF0 - Transceiver Configuration Register 0	144
4.2.2	TR_CONF1 - Transceiver Configuration Register 1	145
4.2.3	TR_CONF2 - Transmitter Configuration Register 2	145
4.2.4	TR_STA - Transceiver Status Register	146
4.2.5	SQRR1 - S/Q-Channel Receive Register 1	147
4.2.6	SQXR1- S/Q-Channel TX Register 1	147
4.2.7	SQRR2 - S/Q-Channel Receive Register 2	148
4.2.8	SQRR3 - S/Q-Channel Receive Register 3	148
4.2.9	ISTATR - Interrupt Status Register Transceiver	148
4.2.10	MASKTR - Mask Transceiver Interrupt	149
4.2.11	ACFG2 - Auxiliary Configuration Register	149
4.3	IOM-2 and MONITOR Handler	151
4.3.1	CDAXy - Controller Data Access Register xy	151
4.3.2	XXX_TSDPxy - Time Slot and Data Port Selection for CHxy	151
4.3.3	CDAX_CR - Control Register Controller Data Access CH1x	152
4.3.4	TR_CR - Control Register Transceiver Data (IOM_CR.CI_CS=0) ...	153
4.3.4.1	TRC_CR - Control Register Transceiver C/I0 (IOM_CR.CI_CS=1)	154
4.3.5	DCI_CR - Control Register for D and CI1 Handler (IOM_CR.CI_CS=0)	154
4.3.6	MON_CR - Control Register Monitor Data	156
4.3.7	SDS_CR - Control Register Serial Data Strobe	156
4.3.8	IOM_CR - Control Register IOM Data	157
4.3.9	STI - Synchronous Transfer Interrupt	159
4.3.10	ASTI - Acknowledge Synchronous Transfer Interrupt	159
4.3.11	MSTI - Mask Synchronous Transfer Interrupt	160
4.3.12	SDS_CONF - Configuration Register for Serial Data Strobe	160
4.3.13	MCDA - Monitoring CDA Bits	161
4.3.14	MOR - MONITOR Receive Channel	161
4.3.15	MOX - MONITOR Transmit Channel	162
4.3.16	MOSR - MONITOR Interrupt Status Register	162

Table of Contents		Page
4.3.17	MOCR - MONITOR Control Register	162
4.3.18	MSTA - MONITOR Status Register	163
4.3.19	MCONF - MONITOR Configuration Register	164
4.4	Interrupt and General Configuration	165
4.4.1	ISTA - Interrupt Status Register	165
4.4.2	MASK - Mask Register	166
4.4.3	AUXI - Auxiliary Interrupt Status Register	166
4.4.4	AUXM - Auxiliary Mask Register	167
4.4.5	MODE1 - Mode1 Register	167
4.4.6	MODE2 - Mode2 Register	169
4.4.7	ID - Identification Register	169
4.4.8	SRES - Software Reset Register	170
4.4.9	TIMR2 - Timer 2 Register	170
5	Electrical Characteristics	172
5.1	Absolute Maximum Ratings	172
5.2	DC Characteristics	173
5.3	Capacitances	174
5.4	Oscillator Specification	175
5.5	AC Characteristics	176
5.6	IOM-2 Interface Timing	177
5.7	Microcontroller Interface Timing	179
5.7.1	Serial Control Interface (SCI) Timing	179
5.7.2	Parallel Microcontroller Interface Timing	180
5.8	Reset	184
5.9	S-Transceiver	185
5.10	Recommended Transformer Specification	186
5.11	Line Overload Protection	187
5.12	EMC / ESD Aspects	188
6	Package Outlines	189
7	Appendix	191

List of Figures		Page
Figure 1	Logic Symbol of the ISAC-SX TE	17
Figure 2	Applications of the ISAC-SX TE	18
Figure 3	Pin Configuration of the ISAC-SX TE	19
Figure 4	Functional Block Diagram of the ISAC-SX TE	26
Figure 5	Serial Control Interface Timing	28
Figure 6	Serial Control Interface Timing	29
Figure 7	Direct/Indirect Register Address Mode	32
Figure 8	Interrupt Status and Mask Registers	33
Figure 9	Reset Generation	34
Figure 10	Timer Interrupt Status Registers	36
Figure 11	Timer 1 Register	37
Figure 12	Timer 2 Register	37
Figure 13	ACL Indication of Activated Layer 1	38
Figure 14	ACL Configuration	38
Figure 15	Wiring Configurations in User Premises	40
Figure 16	S/T -Interface Line Code	41
Figure 17	Frame Structure at Reference Points S and T (ITU I.430)	41
Figure 18	Data Delay between IOM-2 and S/T Interface	44
Figure 19	Data Delay between IOM-2 and S/T Interface with S/G Bit Evaluation	45
Figure 20	Equivalent Internal Circuit of the Transmitter Stage	46
Figure 21	Equivalent Internal Circuit of the Receiver Stage	46
Figure 22	Connection of Line Transformers and Power Supply to the ISAC-SX TE	47
Figure 23	External Circuitry for Transmitter	48
Figure 24	External Circuitry for Symmetrical Receivers	49
Figure 25	External Circuitry for Symmetrical Receivers	50
Figure 26	Disabling of S/T Transmitter	51
Figure 27	External Loop at the S/T-Interface	52
Figure 28	Clock System of the ISAC-SX TE	54
Figure 29	Phase Relationships of ISAC-SX TE Clock Signals	55
Figure 30	Buffered Oscillator Clock Output	56
Figure 31	Layer-1 Control	57
Figure 32	State Diagram Notation	58
Figure 33	State Transition Diagram (TE)	60
Figure 34	State Transition Diagram of Unconditional Transitions (TE)	61
Figure 35	Example of Activation/Deactivation Initiated by the Terminal	67
Figure 36	IOM®-2 Frame Structure in Terminal Mode	69
Figure 37	Architecture of the IOM Handler (Example Configuration)	71
Figure 38	Data Access via CDAX1 and CDAX2 Register Pairs	73
Figure 39	Examples for Data Access via CDAXy Registers	74
Figure 40	Data Access when Looping TSa from DU to DD	75
Figure 41	Data Access when Shifting TSa to TSb on DU (DD)	76

List of Figures	Page
Figure 42	Example for Monitoring Data 77
Figure 43	Interrupt Structure of the Synchronous Data Transfer 79
Figure 44	Examples for the Synchronous Transfer Interrupt Control with one Enabled STIxy 80
Figure 45	Data Strobe Signal 83
Figure 46	Strobed IOM-2 Bit Clock. Register SDS_CONF programmed to 01H . 84
Figure 47	Examples of MONITOR Channel Applications in IOM -2 TE Mode . . . 85
Figure 48	MONITOR Channel Protocol (IOM-2) 87
Figure 49	Monitor Channel, Transmission Abort requested by the Receiver. . . 90
Figure 50	Monitor Channel, Transmission Abort requested by the Transmitter. . 90
Figure 51	Monitor Channel, Normal End of Transmission 90
Figure 52	MONITOR Interrupt Structure 93
Figure 53	CIC Interrupt Structure. 95
Figure 54	Applications of TIC Bus in IOM-2 Bus Configuration 96
Figure 55	Structure of Last Octet of Ch2 on DU 97
Figure 56	Structure of Last Octet of Ch2 on DD 98
Figure 57	D-Channel Access Control on the S-Interface 99
Figure 58	Deactivation of the IOM-2 Interface 100
Figure 59	Activation of the IOM-2 interface 101
Figure 60	RFIFO Operation 106
Figure 61	Data Reception Procedures. 108
Figure 62	Reception Sequence Example. 109
Figure 63	Receive Data Flow. 110
Figure 64	Data Transmission Procedure 115
Figure 65	Transmission Sequence Example 116
Figure 66	Transmit Data Flow 116
Figure 67	Interrupt Status Registers of the HDLC Controllers 118
Figure 68	Layer 2 Test Loops 119
Figure 69	Register Mapping of the ISAC-SX TE 121
Figure 70	Oscillator Circuits 175
Figure 71	Input/Output Waveform for AC Tests. 176
Figure 72	IOM-2 Timing (TE mode) 177
Figure 73	Definition of Clock Period and Width 178
Figure 74	SCI Interface 179
Figure 75	Microprocessor Read Cycle. 180
Figure 76	Microprocessor Write Cycle 180
Figure 77	Multiplexed Address Timing. 180
Figure 78	Non-Multiplexed Address Timing 181
Figure 79	Microprocessor Read Timing 181
Figure 80	Microprocessor Write Cycle 182
Figure 81	Non-Multiplexed Address Timing 183
Figure 82	Reset Signal RES 184

Figure 83	Maximum Line Input Current	187
Figure 84	Transformer Circuitry	188

List of Tables	Page
Table 1	Comparison of the ISAC-SX TE with the previous version
	ISAC-S TE: 13
Table 2	ISAC-SX TE Pin Definitions and Functions 20
Table 3	Host Interface Selection 27
Table 4	Header Byte Code 29
Table 5	Bus Operation Modes 31
Table 6	Reset Source Selection 34
Table 7	ISAC-SX TE Timers 36
Table 8	S/Q-Bit Position Identification and Multiframe Structure 42
Table 9	IOM-2 Clocks 54
Table 10	Examples for Synchronous Transfer Interrupts 79
Table 11	CDA Register Combinations with Correct Read/Write Access 81
Table 12	Transmit Direction 86
Table 13	Receive Direction 86
Table 14	HDLC Controller Address Range 102
Table 15	Receive Byte Count with RBC11...0 in the RBCHD/RBCLD Registers 105
Table 16	Receive Information at RME Interrupt 111
Table 17	XPR Interrupt (availability of XFIFOD) after XTF, XME Commands . 113

1 Overview

The ISDN Subscriber Access Controller for Terminals ISAC-SX TE integrates a D-channel HDLC controller and a four wire S/T interface used to link voice/data terminals to the ISDN. It is based on the ISAC-S TE PSB 2186, and provides enhanced features and functionality.

The system integration is simplified by several configurations of the parallel microcontroller interface selected via pin strapping. They include multiplexed and demultiplexed interface selection as well as the optional indirect register access mechanism which reduces the number of necessary registers in the address space to 2 locations. The ISAC-SX TE also provides a serial control interface (SCI).

The FIFO size of the cyclic D-channel buffer is 64 bytes per direction with programmable block size (threshold). The S-transceiver supports terminals mode (TE), activation/deactivation, timing recovery and D-channel access control and priority control.

One LED output which is capable to indicate the activation status of the S-interface automatically or can be programmed by the host.

The ISAC-SX TE is produced in advanced CMOS technology.

Table 1 Comparison of the ISAC-SX TE with the previous version ISAC-S TE:

	ISAC-SX TE PSB 3186	ISAC-S TE PSB 2186
Operating modes	TE	TE
Supply voltage	3.3 V \pm 5%	5 V \pm 5%
Technology	CMOS	CMOS
Package	P-MQFP-64 / P-TQFP-64	P-MQFP-64 / P-LCC-44 / P-DIP-40
Transceiver Transformer ratio for the transmitter receiver	1:1 1:1	2:1 2:1
Test Functions	- Dig. loop via Layer 2 (TLP) - Layer 1 disable (DIS_TR) - Analog loop (LP_A- bit EXLP- bit, ARL)	- Dig. loop via Layer 2(TLP) - Layer 1 disable (DIS_TR) - Analog loop (ARL)
Microcontroller Interface	Serial interface (SCI) 8-bit parallel interface: Motorola Mux Siemens/Intel Mux Siemens/Intel Non-Mux direct/ indirect Addressing	Not provided 8-bit parallel interface: Motorola Mux Siemens/Intel Mux Siemens/Intel Non-Mux
Command structure of the register access (SCI)	Header/address/data	Address/data
Crystal	7.68 MHz	7.68 MHz
Buffered 7.68 MHz output	Provided	Not provided
Controller data access to IOM-2 timeslots	All timeslots; various possibilities of data access	Restricted access to B- and IC-channel
Data control and manipulation	Various possibilities of data control and data manipulation (enable/ disable, shifting, looping, switching)	B- and IC-channel looping

	ISAC-SX TE PSB 3186	ISAC-S TE PSB 2186
IOM-2		
IOM-2 Interface	Double clock (DCL), bit clock pin (BCL), serial data strobe (SDS)	Double clock (DCL), bit clock (BCL), serial data strobe (SDS)
Monitor channel programming	Provided (MON0, 1, 2, ..., 7)	Provided (MON0 or 1)
C/I channels	CI0 (4 bit), CI1 (4/6 bit)	CI0 (4 bit), CI1 (6 bit)
Layer 1 state machine	With changes for correspondence with the actual ITU specification	
Layer 1 state machine in software	Not possible	Not possible
HDLC support	D- and B-channel timeslots; non-auto mode, transparent mode 1-3, extended transparent mode	D-channel timeslot; auto mode, non-auto mode, transparent mode 1-3
D-channel FIFO size	64 bytes cyclic buffer per direction with programmable FIFO thresholds	2x32 bytes buffer per direction
Reset Signals	\overline{RES} input signal \overline{RSTO} output signal	RST input/output signal
Reset Sources	\overline{RES} Input Watchdog C/I Code Change \overline{EAW} Pin Software Reset	RST Input Watchdog C/I Code Change \overline{EAW} Pin
Interrupt Output Signals	\overline{INT} low active (open drain) by default, reprogrammable to high active (push-pull)	Low active \overline{INT}
Pin SCLK	1.536 MHz	512 kHz

ISDN Subscriber Access Controller for Terminals ISAC-SX TE

PSB/PSF 3186

V 1.4

1.1 Features

- Full duplex 2B + D S/T interface transceiver according to ITU-T I.430
- Successor of ISAC-S TE PSB 2186 in 3.3 V technology
- 8-bit parallel microcontroller interface, Motorola and Siemens/Intel bus type multiplexed or non-multiplexed, direct-/indirect register addressing
- Serial control interface (SCI)
- Microcontroller access to all IOM-2 timeslots
- Various types of protocol support (Non-auto mode, transparent mode, extended transparent mode)
- D-channel HDLC controller with 2 x 64 byte FIFOs
- IOM-2 interface in TE mode, single/double clocks
- One serial data strobe signal (SDS)
- Monitor channel handler (master/slave)
- IOM-2 MONITOR and C/I-channel protocol to control peripheral devices
- Conversion of the frame structure between the S/T-interface and IOM-2
- Receive timing recovery
- D-channel access control
- Activation and deactivation procedures with automatic activation from power down state
- Access to S and Q bits of S/T-interface
- Adaptively switched receive thresholds
- Two programmable timers
- Watchdog timer
- Software Reset

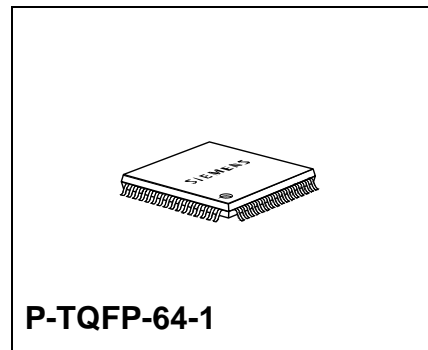
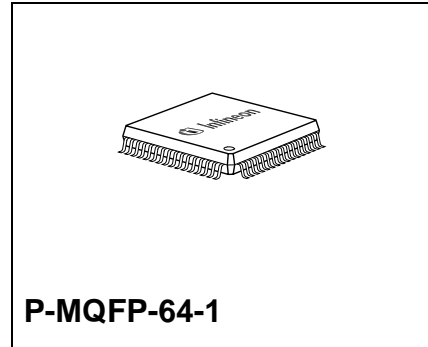

Type	Package
PSB 3186 H	P-MQFP-64-1
PSB 3186 F	P-TQFP-64-1

- One LED pin automatically indicating layer 1 activated state
- Test loops
- Sophisticated power management for restricted power mode
- Power supply 3.3 V
- 3.3 V output drivers, inputs are 5 V safe
- Advanced CMOS technology

1.2 Logic Symbol

The logic symbol gives an overview of the ISAC-SX TE functions.

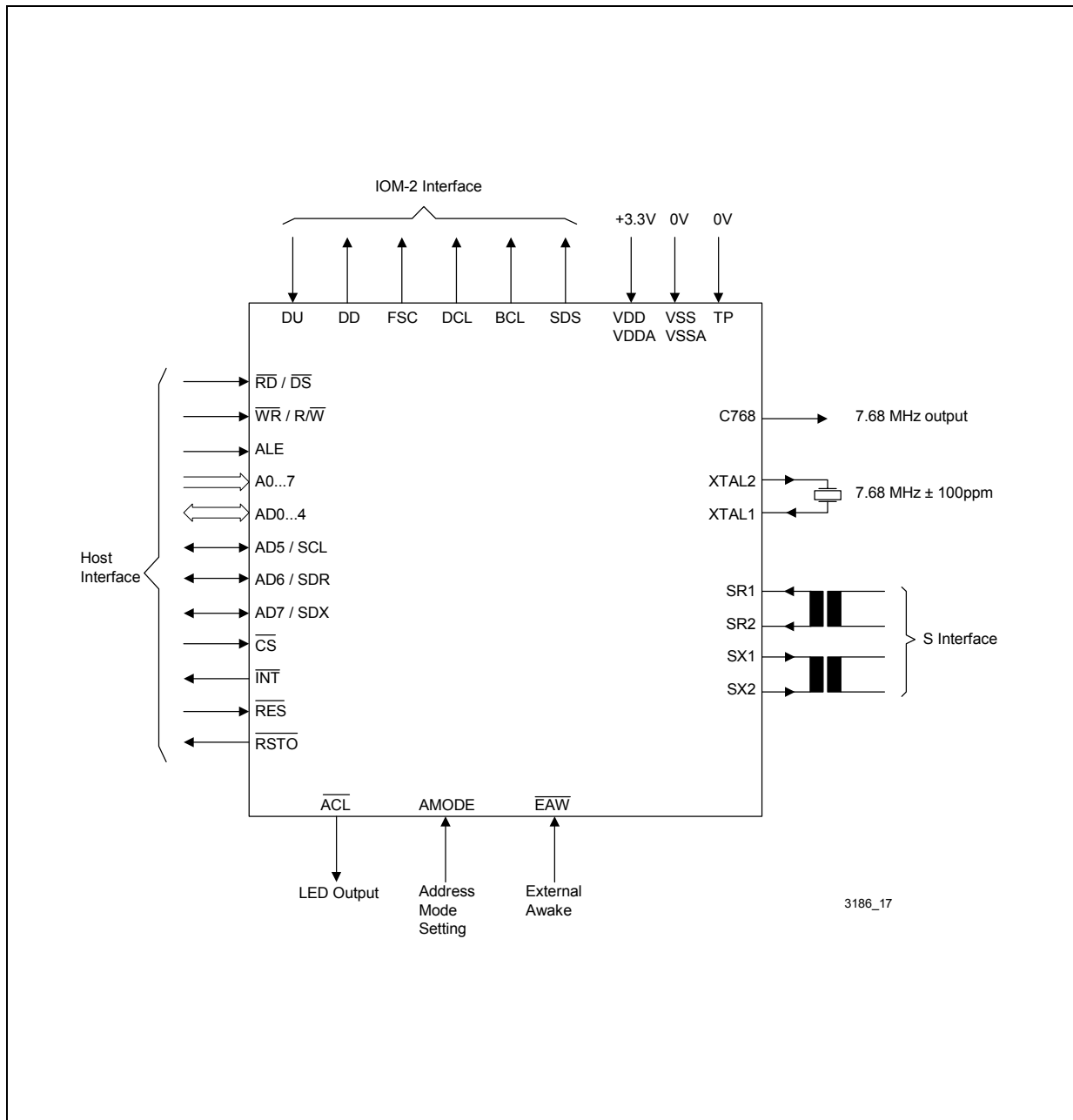

Figure 1 Logic Symbol of the ISAC-SX TE

1.3 Typical Applications

The ISAC-SX TE is designed for the user area of the ISDN basic access, especially for subscriber terminal equipment with S interface.

Figure 2 illustrates the general application fields of the ISAC-SX TE.

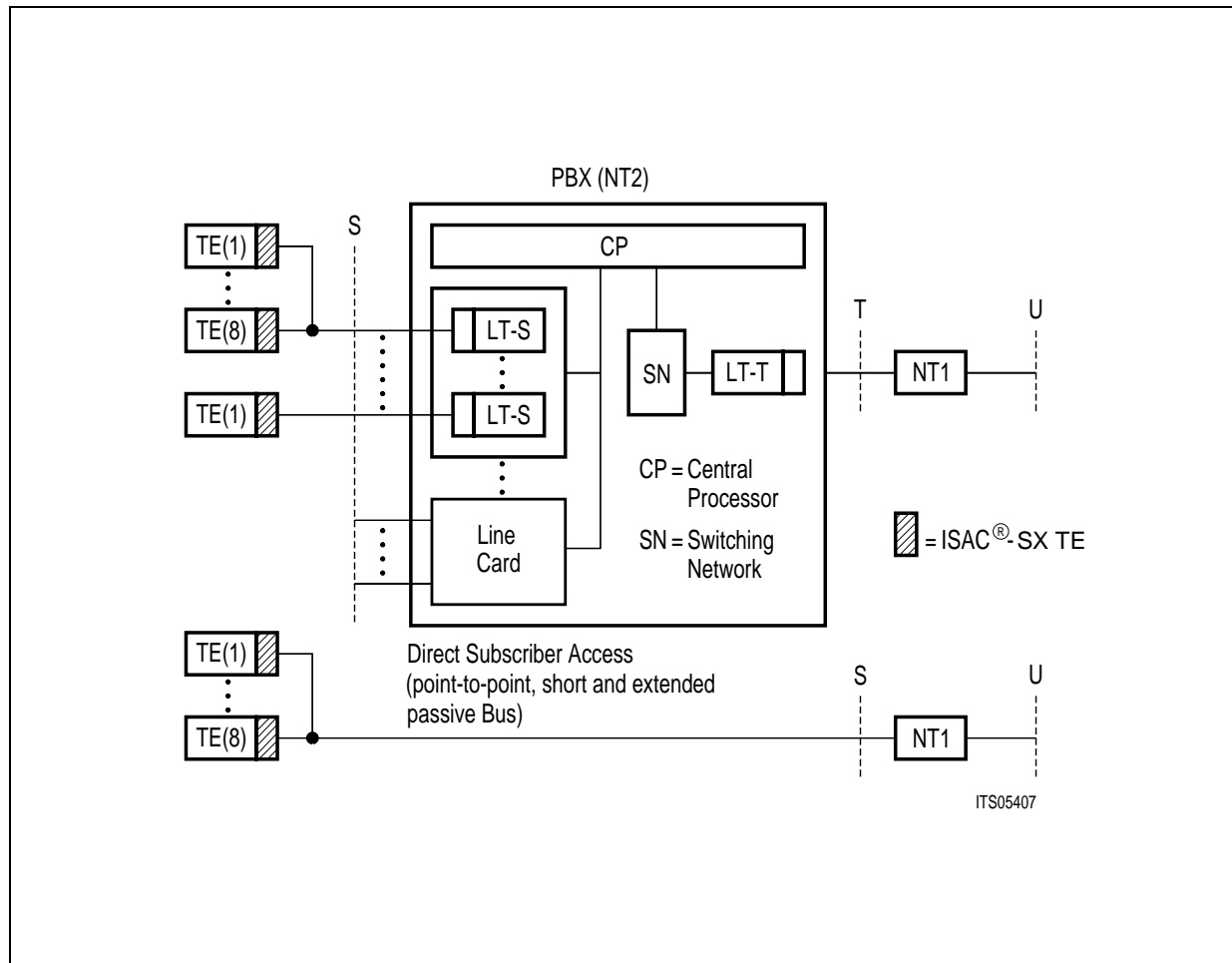

Figure 2 Applications of the ISAC-SX TE

2 Pin Configuration

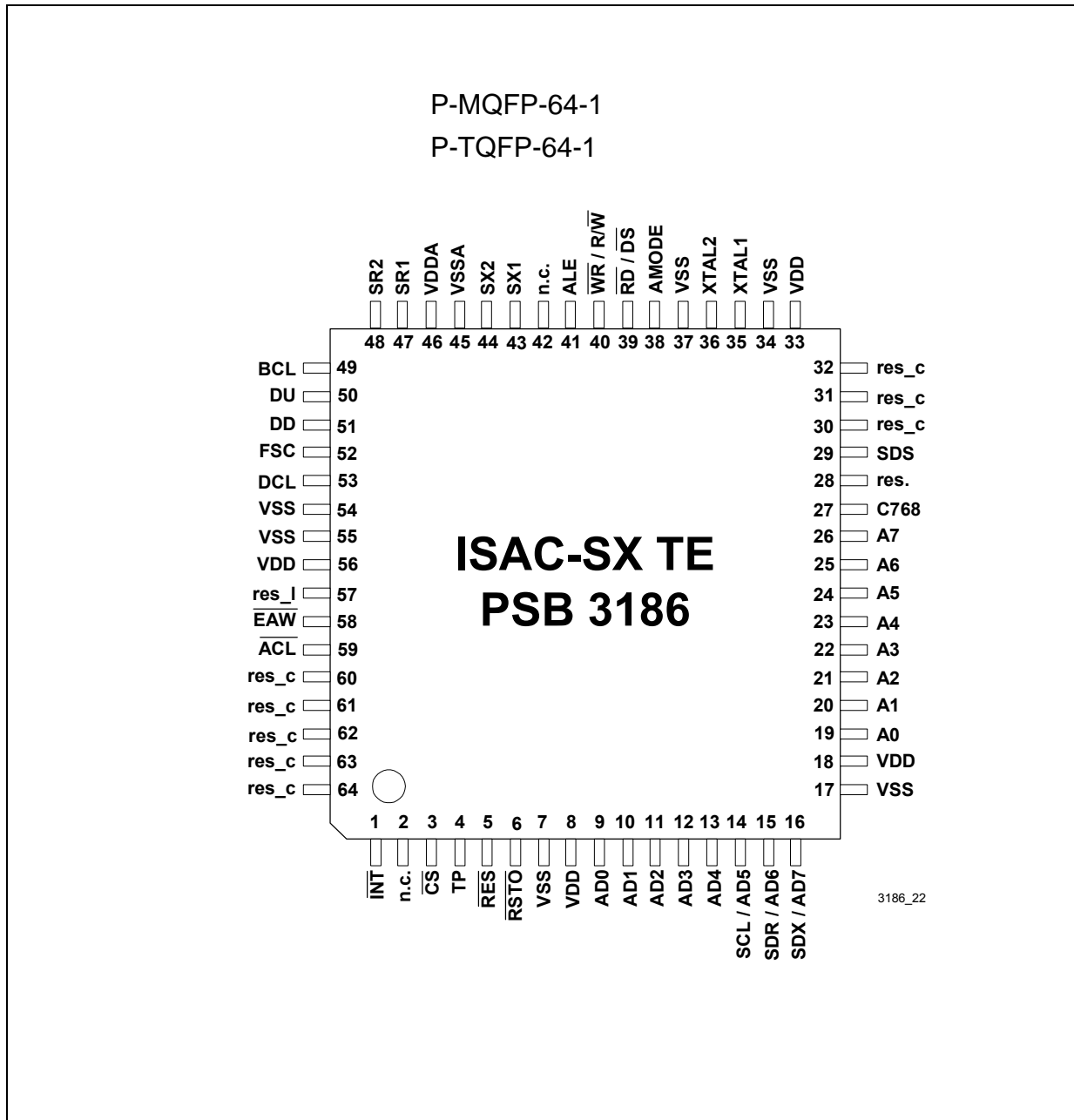

Figure 3 Pin Configuration of the ISAC-SX TE

Table 2 ISAC-SX TE Pin Definitions and Functions

Pin No. MQFP-64 TQFP-64	Symbol	Input (I) Output (O) Open Drain (OD)	Function
-------------------------------	--------	---	----------

Host Interface

19	A0	I	<ul style="list-style-type: none"> • Non-Multiplexed Bus Mode: Address Bus Address bus transfers addresses from the microcontroller to the ISAC-SX TE. For indirect address mode only A0 is valid (A1-A7 to be connected to VDD). • Multiplexed Bus Mode: Not used in multiplexed bus mode. In this case A0-A7 should directly be connected to VDD.
20	A1	I	
21	A2	I	
22	A3	I	
23	A4	I	
24	A5	I	
25	A6	I	
26	A7	I	
9	AD0	I/O	<ul style="list-style-type: none"> • Multiplexed Bus Mode: Address/data bus Transfers addresses from the microcontroller to the ISAC-SX TE and data between the microcontroller and the ISAC-SX TE. • Non-Multiplexed Bus Mode: Data bus Transfers data between the microcontroller and the ISAC-SX TE.
10	AD1	I/O	
11	AD2	I/O	
12	AD3	I/O	
13	AD4	I/O	
14	AD5	I/O	<ul style="list-style-type: none"> • Multiplexed Bus Mode: Address/data bus Address/data line AD5 if the parallel interface is selected. • Non-Multiplexed Bus Mode: Data bus Data line D5 if the parallel interface is selected.
	SCL	I	

Table 2 ISAC-SX TE Pin Definitions and Functions (cont'd)

Pin No. MQFP-64 TQFP-64	Symbol	Input (I) Output (O) Open Drain (OD)	Function
15	AD6 SDR	I/O I	<ul style="list-style-type: none"> • Multiplexed Bus Mode: Address/data bus Address/data line AD6 if the parallel interface is selected. • Non-Multiplexed Bus Mode: Data bus Data line D6 if the parallel interface is selected. SCI - Serial Data Receive Receive data line of the SCI interface if a serial interface is selected.
16	AD7 SDX	I/O OD	<ul style="list-style-type: none"> • Multiplexed Bus Mode: Address/data bus Address/data line AD7 if the parallel interface is selected. • Non-Multiplexed Bus Mode: Data bus Data line D7 if the parallel interface is selected. SCI - Serial Data Transmit Transmit data line of the SCI interface if a serial interface is selected.
39	\overline{RD} \overline{DS}	I I	Read Indicates a read access to the registers (Siemens/ Intel bus mode). Data Strobe The rising edge marks the end of a valid read or write operation (Motorola bus mode).
40	\overline{WR} R/ \overline{W}	I I	Write Indicates a write access to the registers (Siemens/ Intel bus mode). Read/Write A HIGH identifies a valid host access as a read operation and a LOW identifies a valid host access as a write operation (Motorola bus mode).

Table 2 ISAC-SX TE Pin Definitions and Functions (cont'd)

Pin No. MQFP-64 TQFP-64	Symbol	Input (I) Output (O) Open Drain (OD)	Function
41	ALE	I	Address Latch Enable A HIGH on this line indicates an address on the external address/data bus (multiplexed bus type only). ALE also selects the microcontroller interface bus type (multiplexed or non multiplexed).
3	$\overline{\text{CS}}$	I	Chip Select A low level indicates a microcontroller access to the ISAC-SX TE.
1	$\overline{\text{INT}}$	OD (O)	Interrupt Request $\overline{\text{INT}}$ becomes active low (open drain) if the ISAC-SX TE requests an interrupt. The polarity can be reprogrammed to high active with push-pull characteristic.
5	RES	I	Reset A LOW on this input forces the ISAC-SX TE into a reset state.
38	AMODE	I	Address Mode Selects between direct (0) and indirect (1) register access mode.

IOM-2 Interface

52	FSC	O	Frame Sync 8-kHz frame synchronization signal.
53	DCL	O	Data Clock IOM-2 interface data clock signal 1.536 MHz (double bit clock).
49	BCL	O	Bit Clock IOM-2 interface bit clock signal 768 kHz (single bit clock).
51	DD	O (OD)	Data Downstream IOM-2 data signal in downstream direction.

Table 2 ISAC-SX TE Pin Definitions and Functions (cont'd)

Pin No. MQFP-64 TQFP-64	Symbol	Input (I) Output (O) Open Drain (OD)	Function
50	DU	I	Data Upstream IOM-2 data signal in upstream direction.
29	SDS	O	Serial Data Strobe Programmable strobe signal for time slot and/or D-channel indication on IOM-2.

Miscellaneous

43 44	SX1 SX2	O O	S-Bus Transmitter Output (positive) S-Bus Transmitter Output (negative)
47 48	SR1 SR2	I I	S-Bus Receiver Input S-Bus Receiver Input
35	XTAL1	I	Crystal 1 Connection for a crystal or used as external clock input. 7.68 MHz clock or crystal required.
36	XTAL2	O	Crystal 2 Connection for a crystal. Not connected if an external clock is supplied to XTAL1.
58	$\overline{\text{EAW}}$	I	External Awake If a falling edge on this input is detected, the ISAC-SX TE generates an interrupt and, if enabled, a reset pulse.
59	$\overline{\text{ACL}}$	O	Activation LED This pin can either function as a programmable output or it can automatically indicate the activated state of the S interface by a logic '0'. An LED with pre-resistance may directly be connected to $\overline{\text{ACL}}$.
27	C768	O	Clock Output A 7.68 MHz clock is output to support other devices. This clock is not synchronous to the S interface.
6	$\overline{\text{RSTO}}$	OD	Reset Output Low active reset output, either from a watchdog timeout or programmed by the host.

Table 2 ISAC-SX TE Pin Definitions and Functions (cont'd)

Pin No. MQFP-64 TQFP-64	Symbol	Input (I) Output (O) Open Drain (OD)	Function
4	TP	I	Test Pin Must be connected to V_{SS} .
2, 42	n.c.	I	not connected
28	res.		reserved This pin is reserved and should be left not connected.
57	res_l	I	reserved, connect LOW This pin is reserved and must be connected to V_{SS} .
30, 31, 32, 60, 61, 62, 63, 64	res_c	I	reserved, connect HIGH or LOW These pins are reserved and must be connected either to V_{SS} or V_{DD} .

Power Supply

8, 18, 33, 56	V_{DD}	–	Digital Power Supply Voltage (3.3 V \pm 5 %)
46	V_{DDA}	–	Analog Power Supply Voltage (3.3 V \pm 5 %)
7, 17, 34, 37, 54, 55	V_{SS}	–	Digital ground (0 V)
45	V_{SSA}	–	Analog ground (0 V)

3 Description of Functional Blocks

3.1 General Functions and Device Architecture

Figure 4 shows the architecture of the ISAC-SX TE containing the following functions:

- S/T-interface transceiver supporting TE mode
- Different host interface modes:
 - Parallel microcontroller interface (Siemens/Intel multiplexed, Siemens/Intel non multiplexed, Motorola modes)
 - Serial Control Interface (SCI)
- Optional indirect register address mode reduces number of registers to be accessed to two locations
- One D-channel HDLC-controller with 64 byte FIFOs per direction with programmable FIFO block size (threshold) of 4, 8, 16 or 32 byte (receive) and 16 or 32 byte (transmit).
- IOM-2 interface for terminal mode (TE)
- One serial data strobe signals (SDS)
- IOM handler with controller data access registers (CDA) allows flexible access to IOM timeslots for reading/writing, looping and shifting data
- Synchronous transfer interrupts (STI) allow controlled access to IOM timeslots
- MONITOR channel handler on IOM-2 for master mode, slave mode or data exchange
- C/I-channel handler and TIC bus access controller
- D-channel access mechanism
- LED connected to pin \overline{ACL} indicates S-interface activation status automatically or can be controlled by the host
- Level detect circuit on the S interface reduces power consumption in power down mode
- Two timers for periodic or single interrupts (periods between 1 ms and 14.336 s)
- Clock and timing generation
- Digital PLL to synchronize the transceiver to the S/T interface
- Buffered 7.68 MHz oscillator clock output allows connection of further devices and saves another crystal on the system board
- Reset generation (watchdog timer)

Description of Functional Blocks

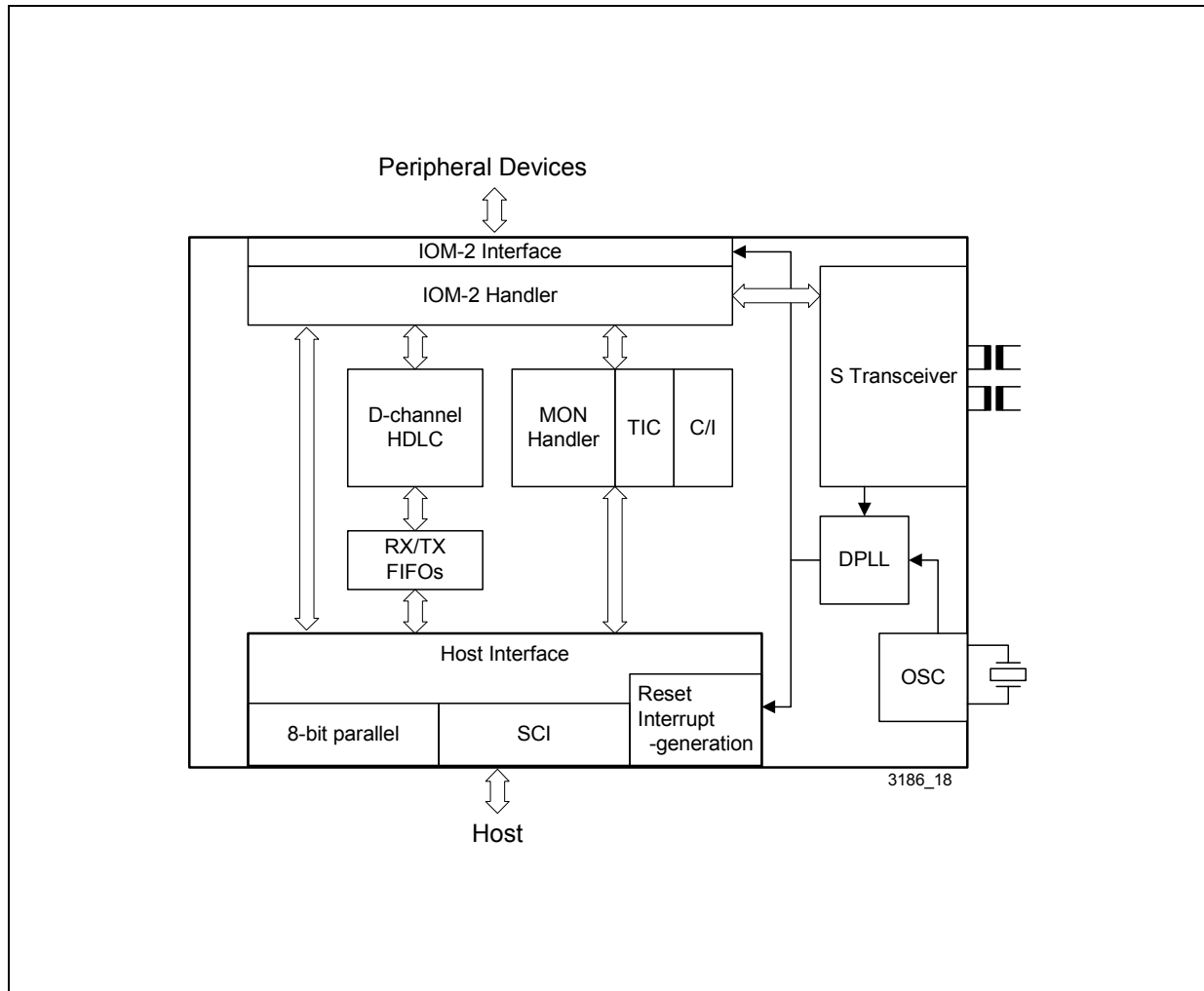

Figure 4 Functional Block Diagram of the ISAC-SX TE

3.2 Microcontroller Interfaces

The ISAC-SX TE supports a serial or a parallel microcontroller interface. For applications where no controller is connected to the ISAC-SX TE microcontroller interface programming is done via the IOM-2 MONITOR channel from a master device. In such applications the ISAC-SX TE operates in the IOM-2 slave mode (refer to the corresponding chapter of the IOM-2 MONITOR handler). This mode is suitable for control functions (e.g. programming registers of the S/T transceiver), but the bandwidth is not sufficient for access to the HDLC controllers.

The interface selections are all done by pinstrapping (see [Table 3](#)). The selection pins are evaluated when the reset input \overline{RES} is active. For the pin levels stated in the tables the following is defined:

- 'High', 'Low': dynamic pin; value must be 'High' or 'Low' only during reset
- V_{DD} , V_{SS} : static pin; pin must statically be strapped to 'High' or 'Low' level
- edge: dynamic pin; any transition ('High' to 'Low', 'Low' to 'High') has occurred

Table 3 Host Interface Selection

PINS		Serial/Parallel Interface	PINS		Interface Type/Mode
\overline{WR} (R/W)	\overline{RD} (DS)		CS	ALE	
'High'	'High'	Parallel	'High'	V_{DD}	Motorola
				V_{SS}	Siemens/Intel Non-Mux
				edge	Siemens/Intel Mux
V_{SS}	V_{SS}	Serial	'High'	V_{SS}	Serial Control Interface(SCI)
		No Host Interface	V_{SS}	V_{SS}	IOM-2 MONITOR Channel (Slave Mode)

Note: For a selected interface mode which doesn't need all input selection and address pins the unused pins must be tied to V_{DD} or V_{SS} .

The interfaces contain all circuitry necessary for the access to programmable registers, status registers and HDLC FIFOs. The mapping of all these registers can be found in [Chapter 4](#).

The microcontroller interface also provides an interrupt request at pin \overline{INT} which is low active by default but can be reprogrammed to high active, a reset input pin \overline{RES} and a reset output pin \overline{RSTO} .

The interrupt request pin \overline{INT} becomes active if the ISAC-SX TE requests an interrupt and this can occur at any time.

Description of Functional Blocks

3.2.1 Serial Control Interface (SCI)

The serial control interface (SCI) is compatible to the SPI interface of Motorola or Siemens C510 family of microcontrollers.

The SCI consists of 4 lines: SCL, SDX, SDR and \overline{CS} . Data is transferred via the lines SDR and SDX at the rate given by SCL. The falling edge of \overline{CS} indicates the beginning of a serial access to the registers. The ISAC-SX TE latches incoming data at the rising edge of SCL and shifts out at the falling edge of SCL. Each access must be terminated by a rising edge of \overline{CS} . Data is transferred in groups of 8 bits with the MSB first.

Figure 5 shows the timing of a one byte read/write access via the serial control interface.

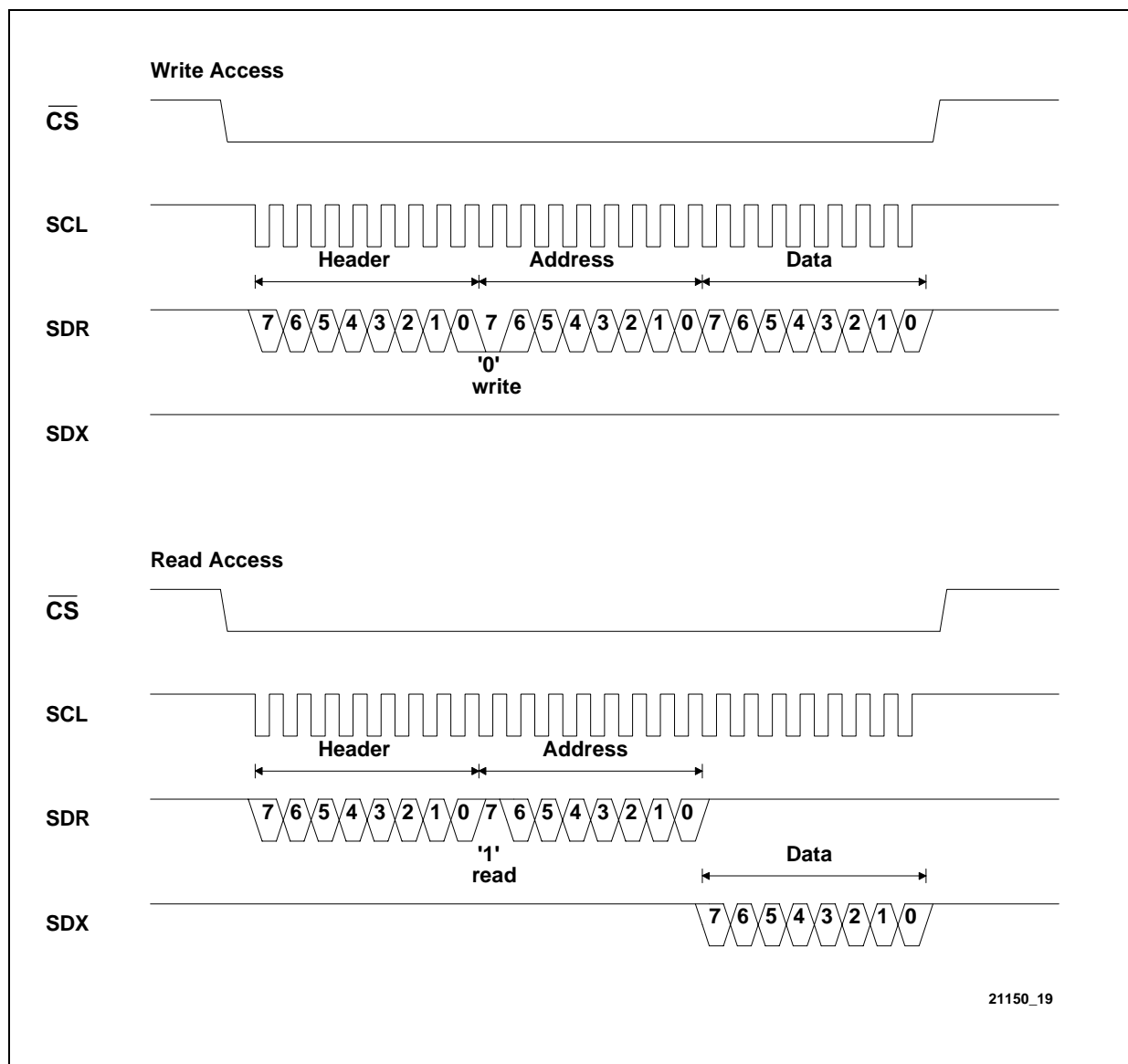

Figure 5 Serial Control Interface Timing

3.2.1.1 Programming Sequences

The basic structure of a read/write access to the ISAC-SX TE registers via the serial control interface is shown in **Figure 6**.

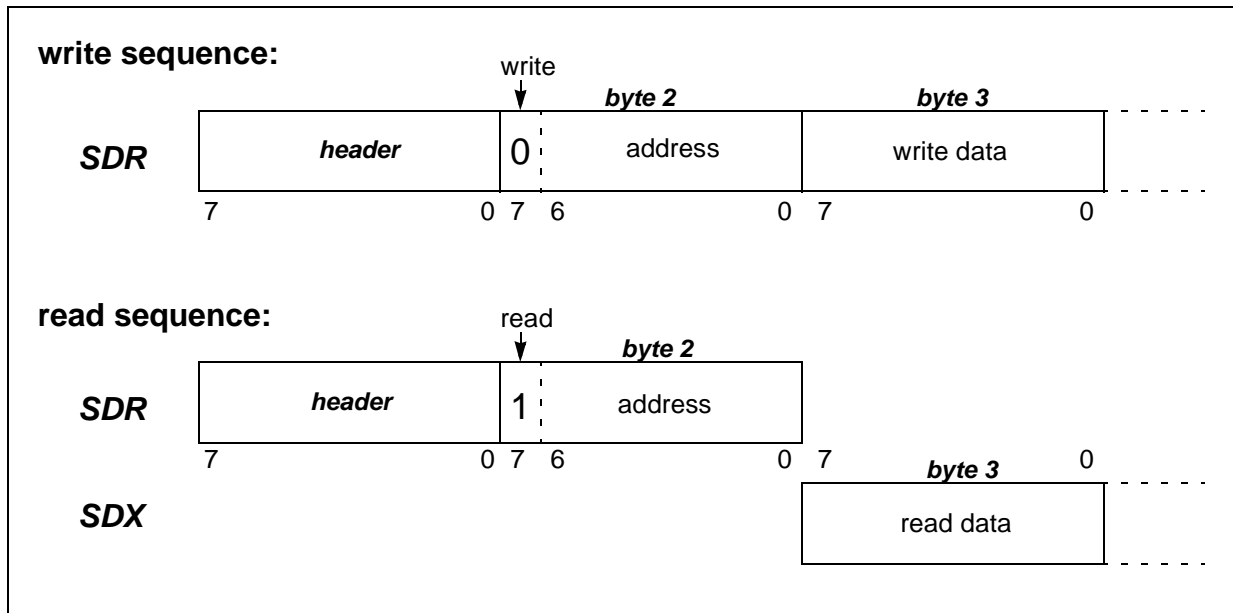

Figure 6 Serial Control Interface Timing

A new programming sequence starts with the transfer of a header byte. The header byte specifies different programming sequences allowing a flexible and optimized access to the individual functional blocks of the ISAC-SX TE.

The possible sequences for access to the complete address range 00_H-7F_H are listed in **Table 4** and described after that.

Table 4 Header Byte Code

Header Byte	Sequence	Sequence Type
$40_H/44_H$	Adr-Data-Adr-Data	Alternating Read/Write (non-interleaved)
$48_H/4C_H$		Alternating Read/Write (interleaved)
$43_H/47_H$	Adr-Data-Data-Data	Read-only/Write-only (constant address)
$41_H/45_H$		Read and following Write-only (non-interleaved)
$49_H/4D_H$		Read and following Write-only (interleaved)

Note: In order to access the address range 00_H-7F_H bit 2 of the header byte must be set to '0' (header bytes 40_H , 48_H , 43_H , 41_H , 49_H), and for the addresses 80_H-FF_H bit 2 must be set to '1' (header bytes 44_H , $4C_H$, 47_H , 45_H , $4D_H$).

Description of Functional Blocks

Header 40_H: Non-interleaved A-D-A-D Sequences

The non-interleaved A-D-A-D sequence gives direct read/write access to the complete address range and can have any length. In this mode SDX and SDR can be connected together allowing data transmission on one line.

Example for a read/write access with header 40_H:

SDR	header	wradr	wrdata	rdadr		rdadr		wradr	wrdata	
SDX					rddata		rdata			

Header 48_H: Interleaved A-D-A-D Sequences

The interleaved A-D-A-D sequence gives direct read/write access to the complete address range and can have any length. This mode allows a time optimized access to the registers by interleaving the data on SDX and SDR (SDR and SDX must not be connected together).

Example for a read/write access with header 48_H:

SDR	header	wradr	wrdata	rdadr	rdadr	wradr	wrdata			
SDX					rddata	rddata				

Header 43_H: Read-/Write- only A-D-D-D Sequence (Constant Address)

This mode can be used for a fast access to the HDLC FIFO data. Any address (rdadr, wradr) in the range 00_H-1F_H and 6A_H/7A_H gives access to the current FIFO location selected by an internal pointer which is automatically incremented with every data byte following the first address byte. The sequence can have any length and is terminated by the rising edge of \overline{CS} .

Example for a write access with header 43_H:

SDR	header	wradr	wrdata	wrdata	wrdata	wrdata	wrdata	wrdata	wrdata	
			(wradr)	(wradr)	(wradr)	(wradr)	(wradr)	(wradr)	(wradr)	
SDX										

Example for a read access with header 43_H:

SDR	header	rdadr								
SDX			rddata	rddata	rddata	rddata	rddata	rddata	rddata	
			(rdadr)	(rdadr)	(rdadr)	(rdadr)	(rdadr)	(rdadr)	(rdadr)	

Description of Functional Blocks
Header 41_H: Non-interleaved A-D-D-D Sequence

This sequence allows in front of the A-D-D-D write access a non-interleaved A-D-A-D read access. This mode is useful for reading status information before writing to the HDLC XFIFO. The termination condition of the read access is the reception of the $\overline{\text{wradr}}$. The sequence can have any length and is terminated by the rising edge of $\overline{\text{CS}}$.

Example for a read/write access with header 41_H:

SDR	header	rdadr		rdadr		wradr	wrdata (wradr)	wrdata (wradr)	wrdata (wradr)	
SDX			rddata		rddata					

Header 49_H: Interleaved A-D-D-D Sequence

This sequence allows in front of the A-D-D-D write access an interleaved A-D-A-D read access. This mode is useful for reading status information before writing to the HDLC XFIFO. The termination condition of the read access is the reception of the $\overline{\text{wradr}}$. The sequence can have any length and is terminated by the rising edge of the $\overline{\text{CS}}$ line.

Example for a read/write access with header 49_H:

SDR	header	rdadr	rdadr	wradr	wrdata (wradr)	wrdata (wradr)	wrdata (wradr)			
SDX			rddata	rddata						

3.2.2 Parallel Microcontroller Interface

The 8-bit parallel microcontroller interface with address decoding on chip allows easy and fast microcontroller access.

The parallel interface of the ISAC-SX TE provides three types of μP buses which are selected via pin ALE. The bus operation modes with corresponding pins are listed in [Table 5](#).

Table 5 Bus Operation Modes

	Bus Mode	Pin ALE	Control Pins
(1)	Motorola	V _{DD}	$\overline{\text{CS}}$, $\overline{\text{R/W}}$, $\overline{\text{DS}}$
(2)	Siemens/Intel non-multiplexed	V _{SS}	$\overline{\text{CS}}$, $\overline{\text{WR}}$, $\overline{\text{RD}}$
(3)	Siemens/Intel multiplexed	Edge	$\overline{\text{CS}}$, $\overline{\text{WR}}$, $\overline{\text{RD}}$, ALE

The occurrence of an edge on ALE, either positive or negative, at any time during the operation immediately selects the interface type (3). A return to one of the other interface types is possible only if a hardware reset is issued.

Description of Functional Blocks

Note: If the multiplexed address/data bus type (3) is selected, the unused address pins A0-A7 must be tied to VDD.

A read/write access to the ISAC-SX TE registers can be done in **multiplexed or non-multiplexed** mode:

- In non-multiplexed mode the register address must be applied to the address bus (A0-A7) for the data access via the data bus (AD0-AD7).
- In multiplexed mode the address on the address/data bus (AD0-AD7) is latched in by ALE before a data read/write access via the same bus is performed.

The ISAC-SX TE provides two different ways to address the register contents which is selected with the AMOD pin ('0' = direct mode, '1' = indirect mode). **Figure 7** illustrates both register addressing modes.

Direct address mode (AMOD = '0'): The register address to be read or written is directly set in the way described above.

Indirect address mode (AMOD = '1'): Only the LSB of the address is used to select either the address register (A0 = '0') or the data register (A0 = '1'). The microcontroller writes the register address to the ADDRESS register before it reads/writes data from/to the corresponding DATA register.

In indirect address mode the ISAC-SX TE evaluates no address line except the least significant address bit. The remaining address lines must not be left open but have to be tied to logical '1'.

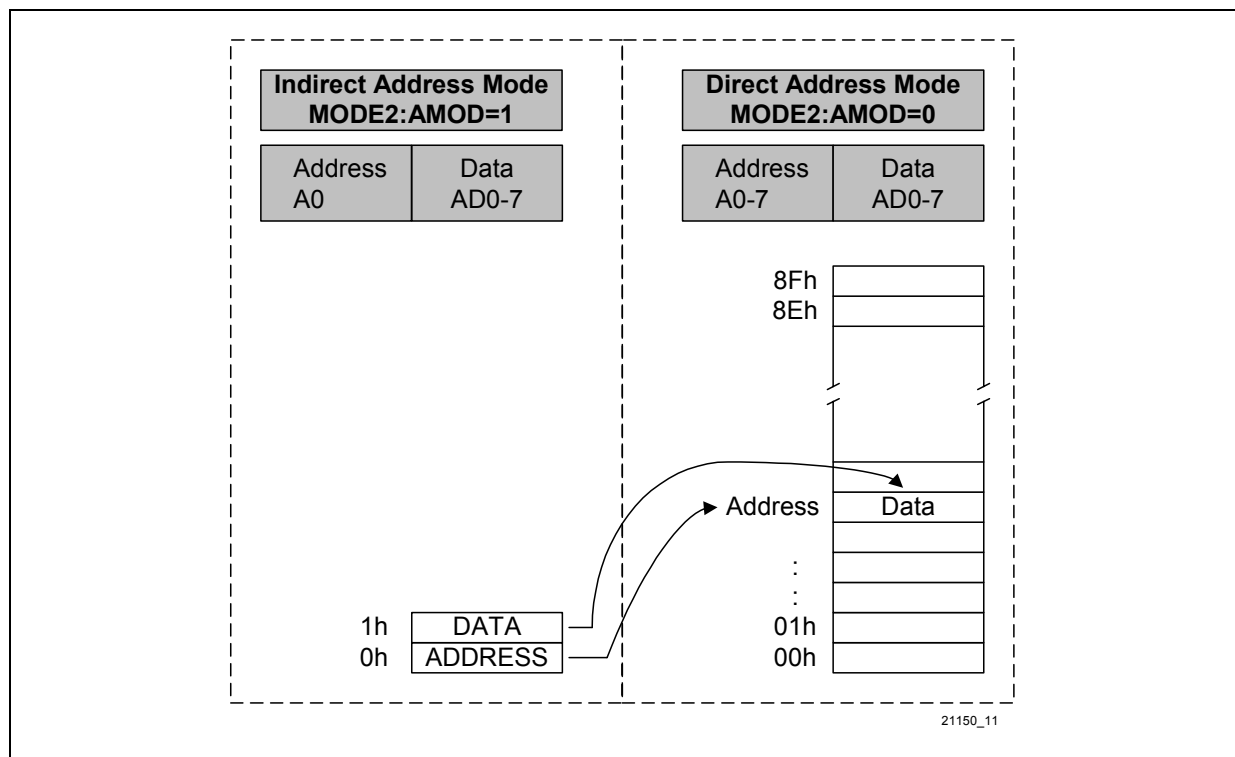

Figure 7 Direct/Indirect Register Address Mode

3.2.3 Interrupt Structure

Special events in the device are indicated by means of a single interrupt output, which requests the host to read status information from the device or transfer data from/to the device.

Since only one interrupt request pin (\overline{INT}) is provided, the cause of an interrupt must be determined by the host reading the interrupt status registers of the device.

The structure of the interrupt status registers is shown in **Figure 8**.

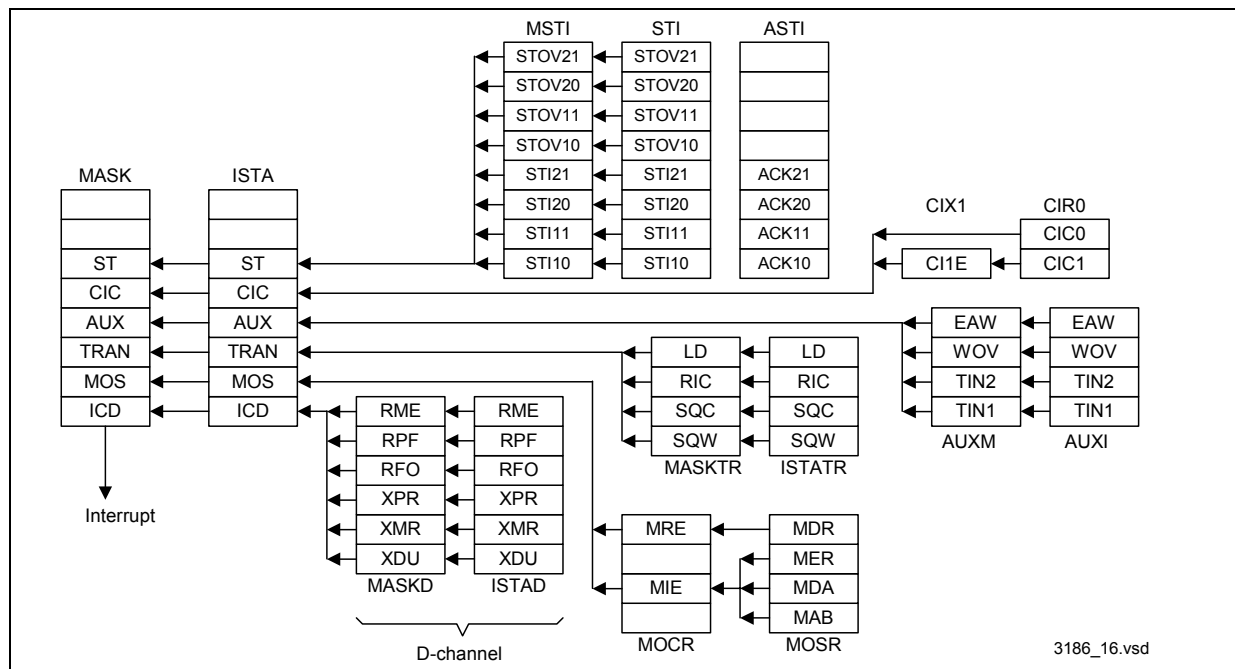

Figure 8 Interrupt Status and Mask Registers

All six interrupt bits in the ISTA register point at interrupt sources in the D-channel HDLC Controller (ICD), Monitor- (MOS) and C/I- (CIC) handler, the transceiver (TRAN), the synchronous transfer (ST) and the auxiliary interrupts (AUXI).

All these interrupt sources are described in the corresponding chapters. After the device has requested an interrupt activating the interrupt pin (\overline{INT}), the host must read first the device interrupt status register (ISTA) in the associated interrupt service routine. The interrupt pin of the device remains active until all interrupt sources are cleared by reading the corresponding interrupt register. Therefore it is possible that the interrupt pin is still active when the interrupt service routine is finished.

Each interrupt indication of the interrupt status registers can selectively be masked by setting the respective bit in the MASK register.

For some interrupt controllers or hosts it might be necessary to generate a new edge on the interrupt line to recognize pending interrupts. This can be done by masking all interrupts at the end of the interrupt service routine (writing FF_H into the MASK register) and write back the old mask to the MASK register.

3.2.4 Reset Generation

Figure 9 shows the organization of the reset generation of the device.

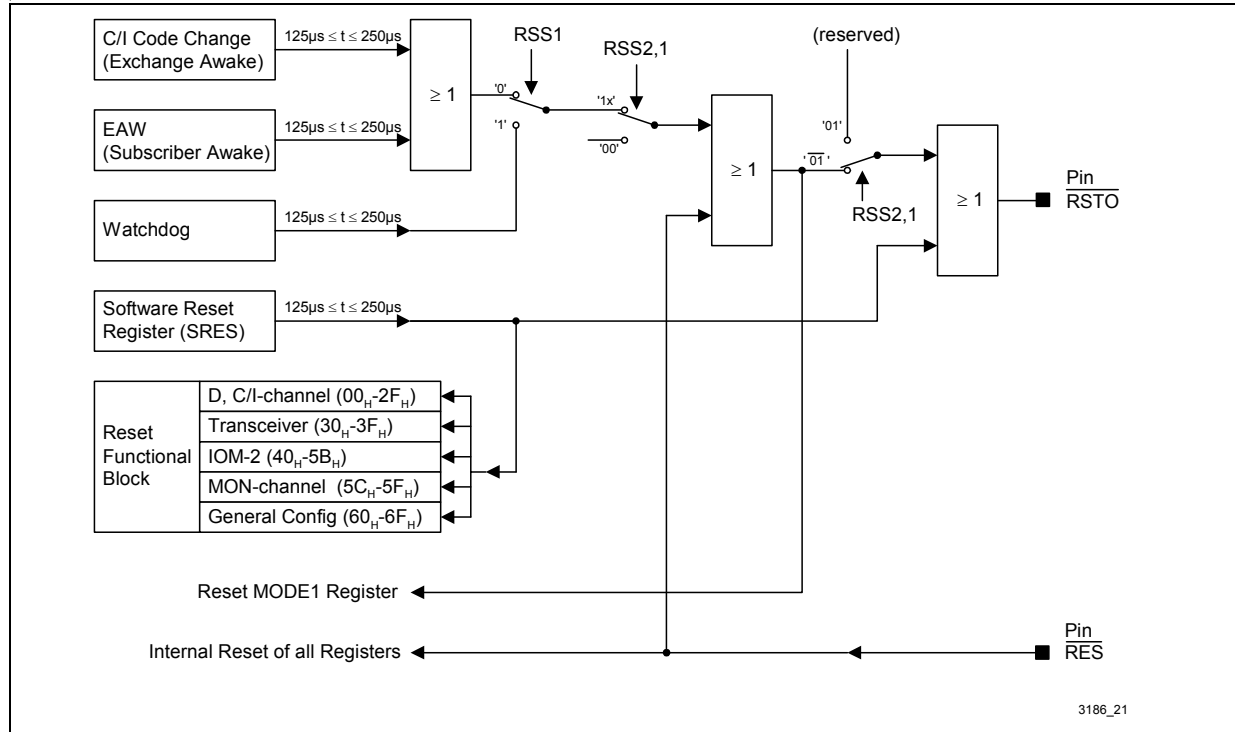

Figure 9 Reset Generation

Reset Source Selection

The internal reset sources C/I code change, \overline{EAW} and Watchdog can be output at the low active reset pin \overline{RSTO} . The selection of these reset sources can be done with the RSS2,1 bits in the MODE1 register according Table 6.

The setting RSS2,1 = '01' is reserved for further use. In this case no reset except software reset (SRES.RSTO) is output on \overline{RSTO} . The internal reset sources set the MODE1 register to its reset value.

Table 6 Reset Source Selection

RSS2 Bit 1	RSS1 Bit 0	C/I Code Change	EAW	Watchdog Timer
0	0	--	--	--
0	1	reserved		
1	0	X	X	--
1	1	--	--	X

Description of Functional Blocks

- **C/I Code Change (Exchange Awake)**

A change in the downstream C/I channel (C/I0) generates an external reset pulse of $125 \mu\text{s} \leq t \leq 250 \mu\text{s}$.

- **$\overline{\text{EAW}}$ (Subscriber Awake)**

A low level on the $\overline{\text{EAW}}$ input starts the oscillator from the power down state and generates a reset pulse of $125 \mu\text{s} \leq t \leq 250 \mu\text{s}$.

- **Watchdog Timer**

After the selection of the watchdog timer (RSS = '11') an internal timer is reset and started. During every time period of 128 ms the microcontroller has to program the WTC1- and WTC2 bits in the following sequence to reset and restart the watchdog timer:

	WTC1	WTC2
1.	1	0
2.	0	1

If not, the timer expires and a WOV-interrupt (ISTA Register) together with a reset pulse of $125 \mu\text{s}$ is generated.

Deactivation of the watchdog timer is only possible with a hardware reset.

External Reset Input

At the $\overline{\text{RES}}$ input an external reset can be applied forcing the device in the reset state. This external reset signal is additionally fed to the $\overline{\text{RSTO}}$ output. The length of the reset signal is specified in [Chapter 5.8](#).

After an external reset from the $\overline{\text{RES}}$ pin all registers of the device are set to its reset values (see register description in [Chapter 4](#)).

Software Reset Register (SRES)

Every main functional block of the device can be reset separately by software setting the corresponding bit in the SRES register. A reset to external devices can also be controlled in this way. The reset state is activated by setting the corresponding bit to '1' and onchip logic resets this bit again automatically after 4 BCL clock cycles. The address range of the registers which will be reset at each SRES bit is listed in [Figure 9](#).

3.2.5 Timer Modes

The ISAC-SX TE provides two timers which can be used for various purposes. Each of them provides two modes ([Table 7](#)), a count down timer interrupt, i.e. an interrupt is generated only once after expiration of the selected period, and a periodic timer interrupt, which means an interrupt is generated continuously after every expiration of that period.

Table 7 ISAC-SX TE Timers

Address	Register	Modes	Period
24 _H	TIMR1	Periodic	64 ... 2048 ms
		Count Down	64 ms ... 14.336 s
65 _H	TIMR2	Periodic	1 ... 63 ms
		Count Down	1 ... 63 ms

When the programmed period has expired an interrupt is generated and indicated in the auxiliary interrupt status ISTA.AUX. The source of the interrupt can be read from AUXI (TIN1, TIN2) and each of the interrupt sources can be masked in AUXM.

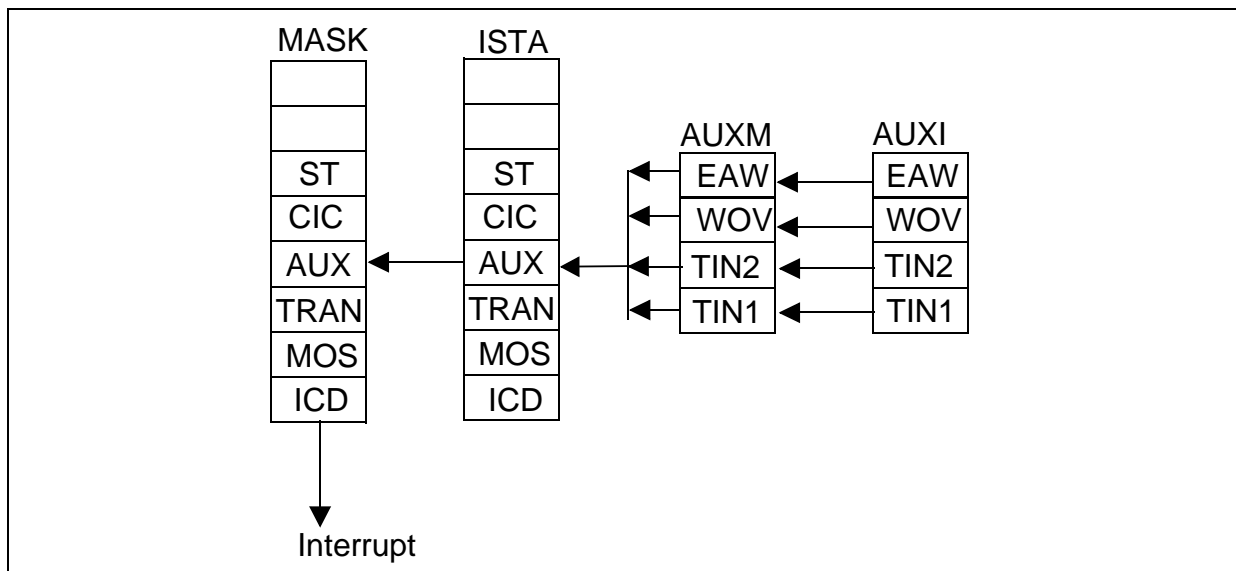

Figure 10 Timer Interrupt Status Registers

Timer 1

The host controls the timer 1 by setting bit CMDRD.STI to start the timer and by writing register TIMR1 to stop the timer. After time period T1 an interrupt (AUXI.TIN1) is generated continuously if CNT= 7 or a single interrupt is generated after timer period T if CNT<7 (**Figure 11**).

Description of Functional Blocks

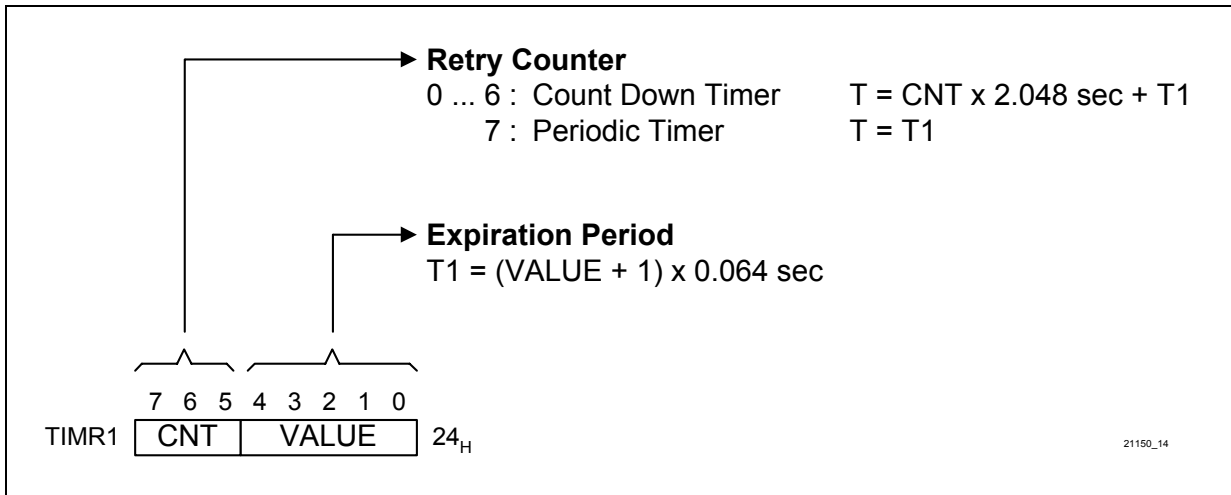

Figure 11 Timer 1 Register

Timer 2

The host starts and stops timer 2 in TIMR2.CNT (Figure 12). If TIMR2.TMD=0 the timer is operating in count down mode, for TIMR2.TMD=1 a periodic interrupt AUXI.TIN2 is generated. The timer length (for count down timer) or the timer period (for periodic timer), respectively, can be configured to a value between 1 - 63 ms (TIMR2.CNT).

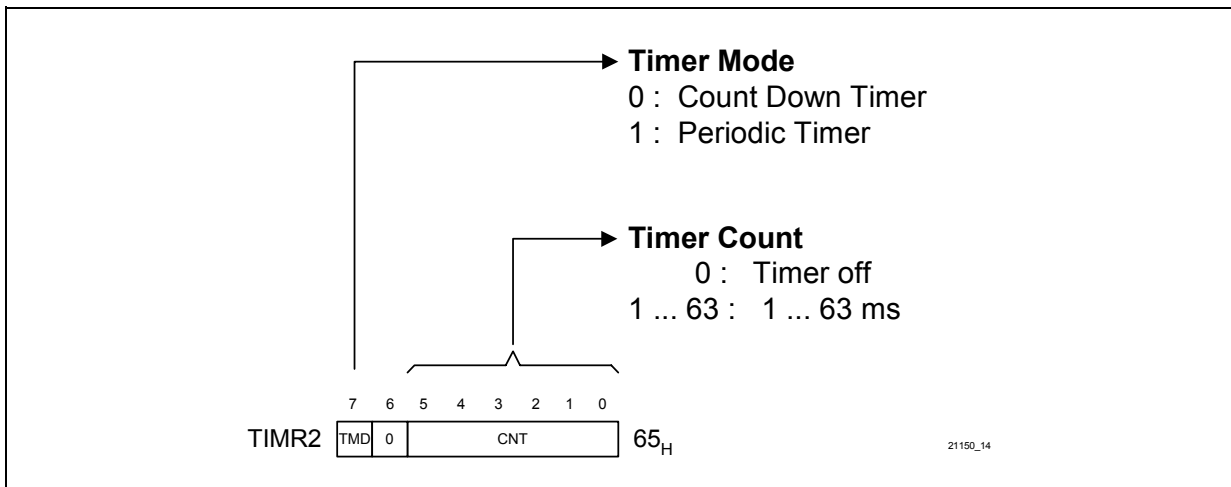

Figure 12 Timer 2 Register

3.2.6 Activation Indication via Pin ACL

The activated state of the S-interface is directly indicated via pin \overline{ACL} (Activation LED). An LED with pre-resistance may directly be connected to this pin and a low level is driven on \overline{ACL} as soon as the layer 1 state machine reaches the activated state (see [Figure 13](#)).

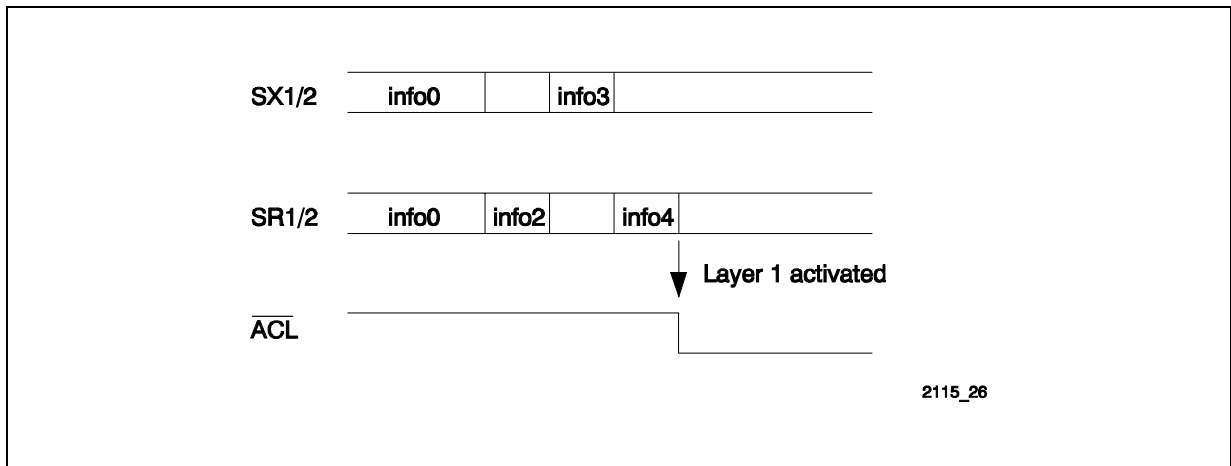

Figure 13 ACL Indication of Activated Layer 1

By default (ACFG2.ACL=0) the state of layer 1 is indicated at pin \overline{ACL} . If the automatic indication of the activated layer 1 is not required, the state on pin \overline{ACL} can also be controlled by the host (see [Figure 14](#)).

If ACFG2.ACL=1 the LED on pin \overline{ACL} can be switched on (ACFG2.LED=1) and off (ACFG2.LED=0) by the host.

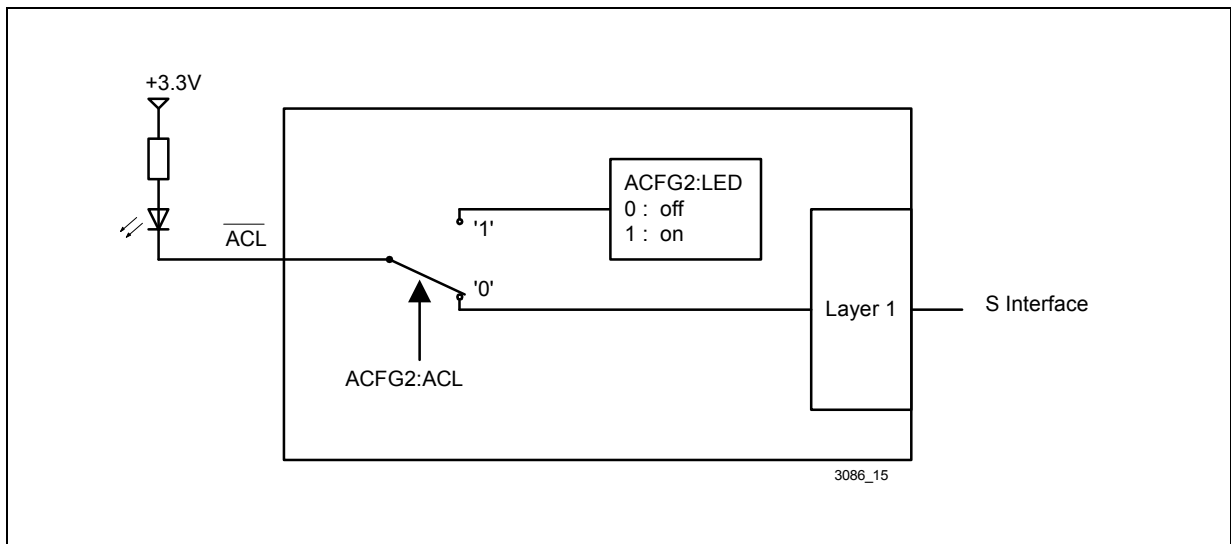

Figure 14 ACL Configuration

3.3 S/T-Interface

The layer-1 functions for the S/T interface of the ISAC-SX TE are:

- line transceiver functions for the S/T interface according to the electrical specifications of ITU-T I.430;
- conversion of the frame structure between IOM-2 and S/T interface;
- conversion from/to binary to/from pseudo-ternary code;
- level detection
- receive timing recovery for point-to-point, passive bus and extended passive bus configuration
- S/T timing generation using IOM-2 timing synchronous to system, or vice versa;
- D-channel access control and priority handling;
- D-channel echo bit generation by handling of the global echo bit;
- activation/deactivation procedures, triggered by primitives received over the IOM-2 C/I channel or by INFO's received from the line;
- execution of test loops.

The wiring configurations in user premises, in which the ISAC-SX TE can be used, are illustrated in **Figure 15**.

Description of Functional Blocks

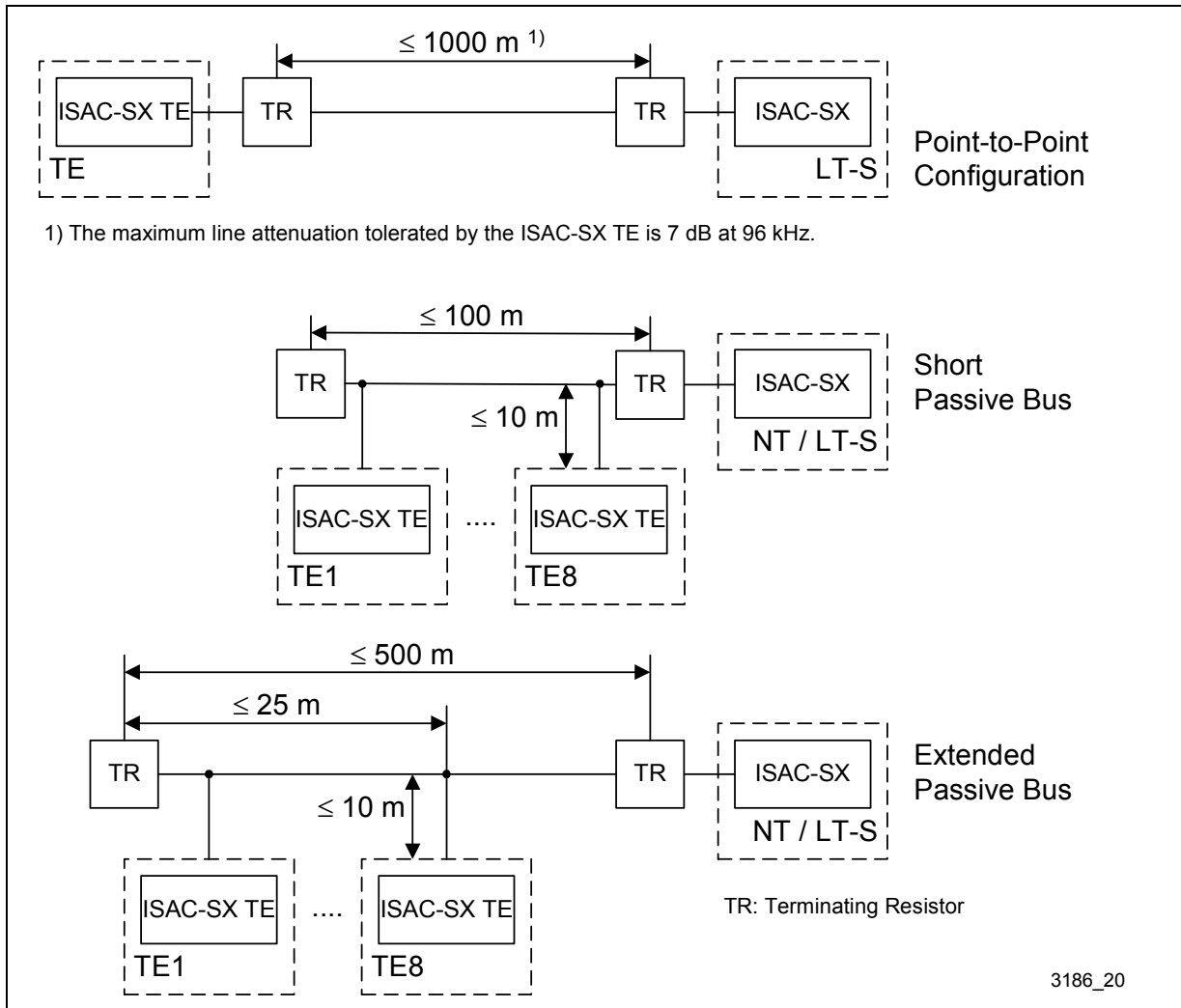

Figure 15 Wiring Configurations in User Premises

3.3.1 S/T-Interface Coding

Transmission over the S/T-interface is performed at a rate of 192 kbit/s. 144 kbit/s are used for user data (B1+B2+D), 48 kbit/s are used for framing and maintenance information.

Line Coding

The following figure illustrates the line code. A binary ONE is represented by no line signal. Binary ZEROs are coded with alternating positive and negative pulses with two exceptions:

For the required frame structure a code violation is indicated by two consecutive pulses of the same polarity. These two pulses can be adjacent or separated by binary ONES. In bus configurations a binary ZERO always overwrites a binary ONE.

Description of Functional Blocks

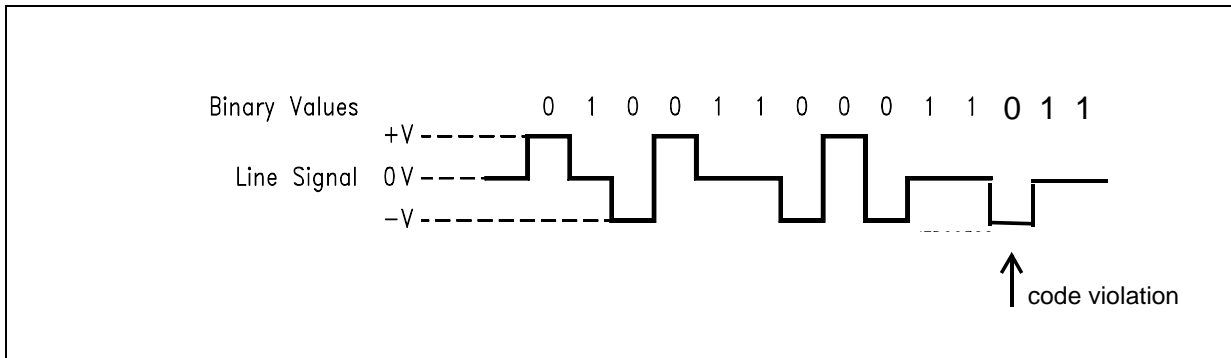

Figure 16 S/T-Interface Line Code

Frame Structure

Each S/T frame consists of 48 bits at a nominal bit rate of 192 kbit/s. For user data (B1+B2+D) the frame structure applies to a data rate of 144 kbit/s (see Figure 17). In the direction TE → NT the frame is transmitted with a two bit offset. For details on the framing rules please refer to ITU I.430 section 6.3. The following figure illustrates the standard frame structure for both directions (NT → TE and TE → NT) with all framing and maintenance bits.

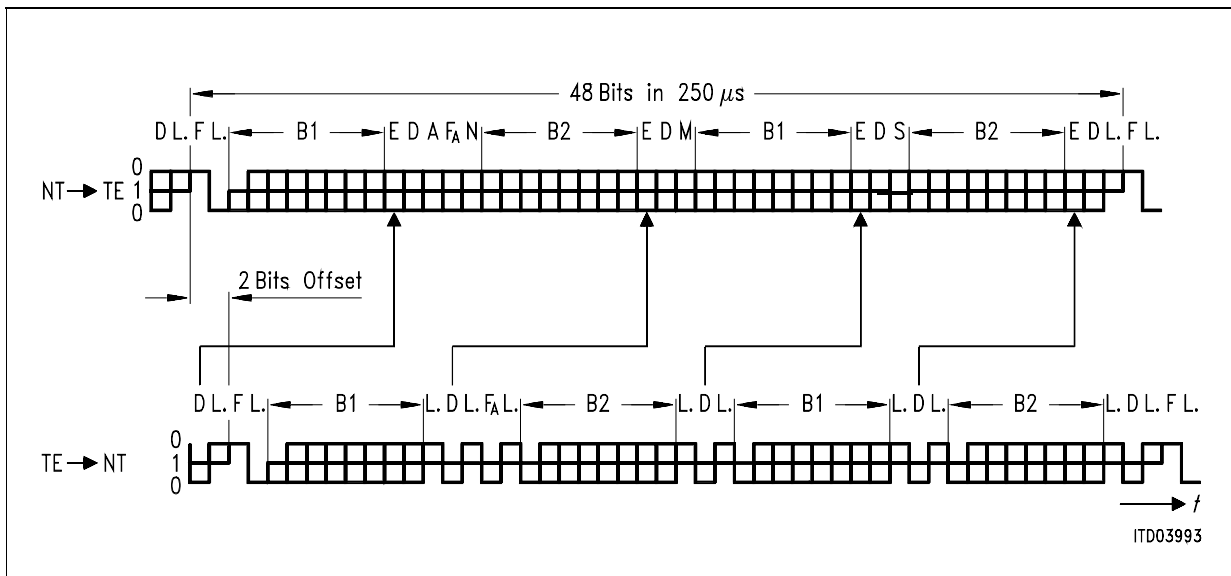

Figure 17 Frame Structure at Reference Points S and T (ITU I.430)

Note: The ITU I.430 standard specifies S1 - S5 for optional use.

Description of Functional Blocks

– F	Framing Bit	F = (0b) → identifies new frame (always positive pulse, always code violation)
– L.	D.C. Balancing Bit	L. = (0b) → number of binary ZEROs sent after the last L. bit was odd
– D	D-Channel Data Bit	Signaling data specified by user
– E	D-Channel Echo Bit	E = D → received E-bit is equal to transmitted D-bit
– F _A	Auxiliary Framing Bit	See section 6.3 in ITU I.430
– N		$N = \overline{F_A}$
– B1	B1-Channel Data Bit	User data
– B2	B2-Channel Data Bit	User data
– A	Activation Bit	A = (0b) → INFO 2 transmitted A = (1b) → INFO 4 transmitted
– S	S-Channel Data Bit	S ₁ channel data (see note below)
– M	Multiframe Bit	M = (1b) → Start of new multiframe

3.3.2 S/T-Interface Multiframe

According to ITU recommendation I.430 a multiframe provides extra layer 1 capacity in the TE-to-NT direction by using an extra channel between the TE and NT (Q-channel). The Q bits are defined to be the bits in the F_A bit position.

In the NT-to-TE direction the S-channel bits are used for information transmission. One S channel (S₁) out of five possible S-channels can be accessed by the ISAC-SX TE.

In the NT-to-TE direction the S-channel bits are used for information transmission.

The S and Q channels are accessed via the μC interface or the IOM-2 MONITOR channel, respectively, by reading/writing the SQR or SQX bits in the S/Q channel registers (SQRRx, SQXRx).

Table 8 shows the S and Q bit positions within the multiframe.

Table 8 S/Q-Bit Position Identification and Multiframe Structure

After multiframe synchronization has been established, the Q data will be inserted at the upstream (TE → NT) F_A bit position in each 5th S/T frame (see **Table 8**).

When synchronization is not achieved or lost, each received F_A bit is mirrored to the next transmitted F_A bit.

Multiframe synchronization is achieved after two complete multiframe have been detected with reference to F_A/N bit and M bit positions. Multiframe synchronization is lost if bit errors in F_A/N bit or M bit positions have been detected in two consecutive

Description of Functional Blocks

Frame Number	NT-to-TE F _A Bit Position	NT-to-TE M Bit	NT-to-TE S Bit	TE-to-NT F _A Bit Position
1	ONE	ONE	S11	Q1
2	ZERO	ZERO	S21	ZERO
3	ZERO	ZERO	S31	ZERO
4	ZERO	ZERO	S41	ZERO
5	ZERO	ZERO	S51	ZERO
6	ONE	ZERO	S12	Q2
7	ZERO	ZERO	S22	ZERO
8	ZERO	ZERO	S32	ZERO
9	ZERO	ZERO	S42	ZERO
10	ZERO	ZERO	S52	ZERO
11	ONE	ZERO	S13	Q3
12	ZERO	ZERO	S23	ZERO
13	ZERO	ZERO	S33	ZERO
14	ZERO	ZERO	S43	ZERO
15	ZERO	ZERO	S53	ZERO
16	ONE	ZERO	S14	Q4
17	ZERO	ZERO	S24	ZERO
18	ZERO	ZERO	S34	ZERO
19	ZERO	ZERO	S44	ZERO
20	ZERO	ZERO	S54	ZERO
1	ONE	ONE	S11	Q1
2	ZERO	ZERO	S21	ZERO

multiframes. The synchronization state is indicated by the MSYN bit in the S/Q-channel receive register (SQRR1).

The multiframe synchronization can be enabled or disabled by programming the MFEN bit in the S/Q-channel transmit register (SQXR1).

Interrupt Handling for Multiframe

To trigger the microcontroller for a multiframe access an interrupt can be generated once per multiframe (SQW) or if the received S-channels have changed (SQC).

In both cases the microcontroller has access to the multiframe within the duration of one multiframe (5 ms).

Description of Functional Blocks

3.3.3 Data Transfer and Delay between IOM-2 and S/T

In the state F7 (Activated) the B1, B2, D and E bits are transferred transparently from the S/T to the IOM-2 interface. In all other states '1's are transmitted to the IOM-2 interface. To transfer data transparently to the S/T interface any activation request C/I command (AR8, AR10 or ARL) is additionally necessary. **Figure 18** shows the data delay between the IOM-2 and the S/T interface and vice versa.

For the D channel the delay from the IOM-2 to the S/T interface is only valid if S/G evaluation is disabled (MODED.DIM0=0). If S/G evaluation is enabled (MODED.DIM2-0=0x1) the delay depends on the selected priority and the relation between the echo bits on S and the D channel bits on the IOM-2, e.g. for priority 8 the timing relation between the 8th D-bit on S bus and the D-channel on IOM-2.

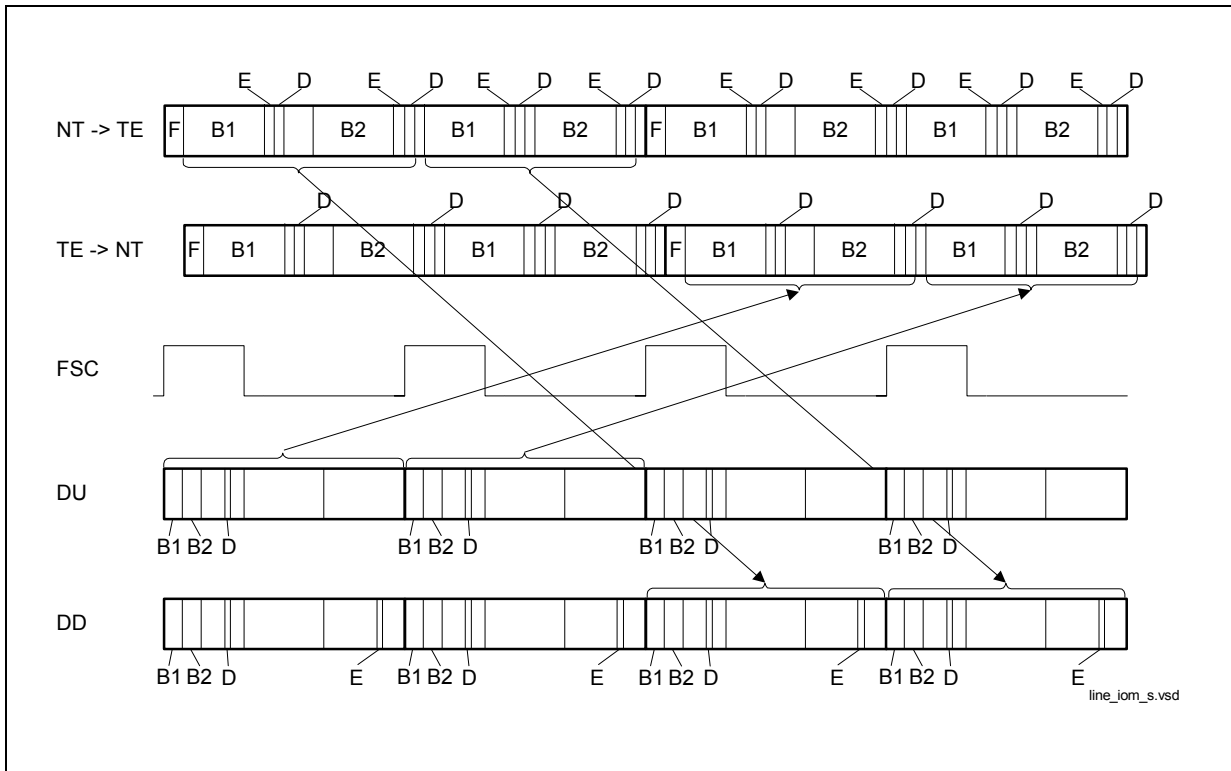

Figure 18 Data Delay between IOM-2 and S/T Interface

Description of Functional Blocks

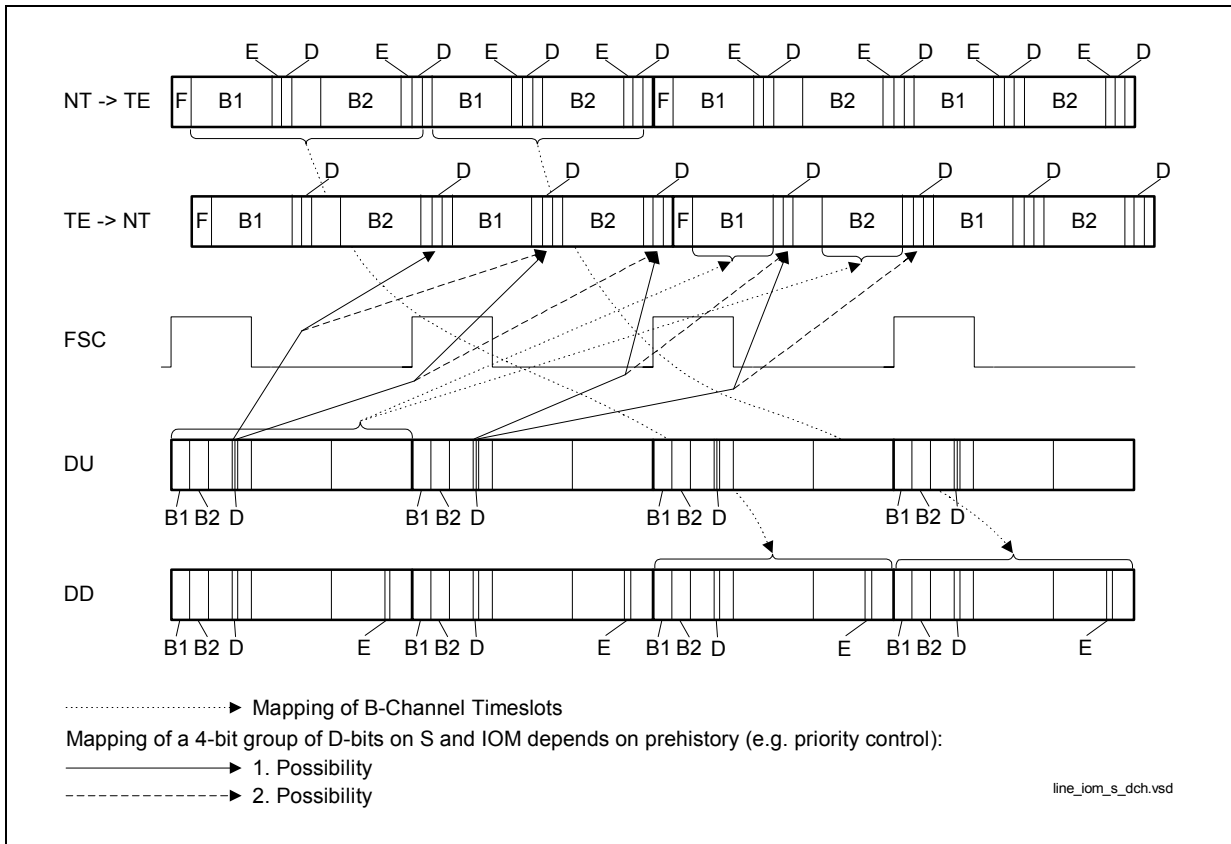

Figure 19 Data Delay between IOM-2 and S/T Interface with S/G Bit Evaluation

3.3.4 Transmitter Characteristics

The full-banded pseudo-ternary pulse shaping is achieved with the integrated transmitter which is realized as a symmetrical current limited voltage source ($V_{SX1/SX2} = +/-1.0 V$; $I_{max} = 26 mA$). The equivalent circuit of the transmitter is shown in [Figure 20](#).

The nominal pulse amplitude on the S-interface 750 mV (zero-peak) is adjusted with external resistors (see [Chapter 3.3.6.1](#)).

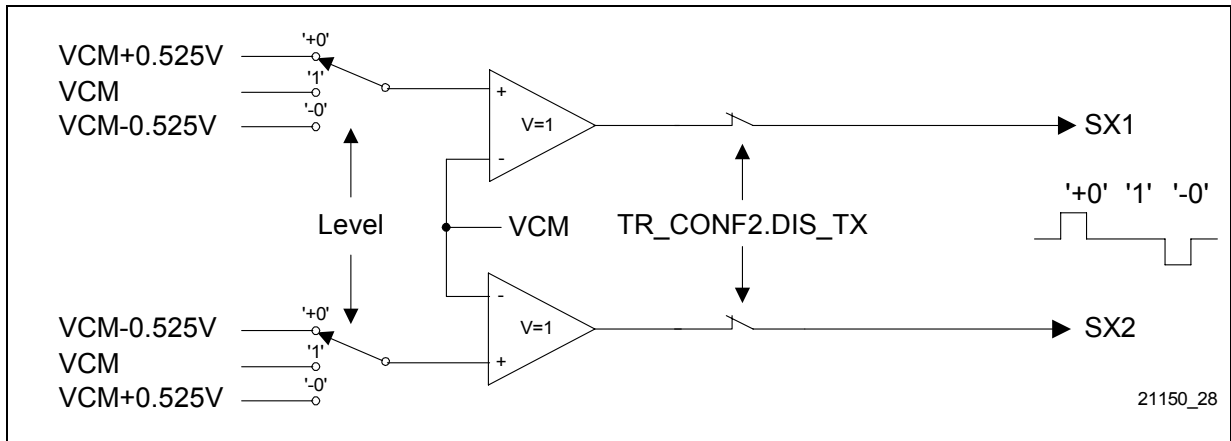

Figure 20 Equivalent Internal Circuit of the Transmitter Stage

3.3.5 Receiver Characteristics

The receiver consists of a differential input stage, a peak detector and a set of comparators. Additional noise immunity is achieved by digital oversampling after the comparators. A simplified equivalent circuit of the receiver is shown in [Figure 21](#).

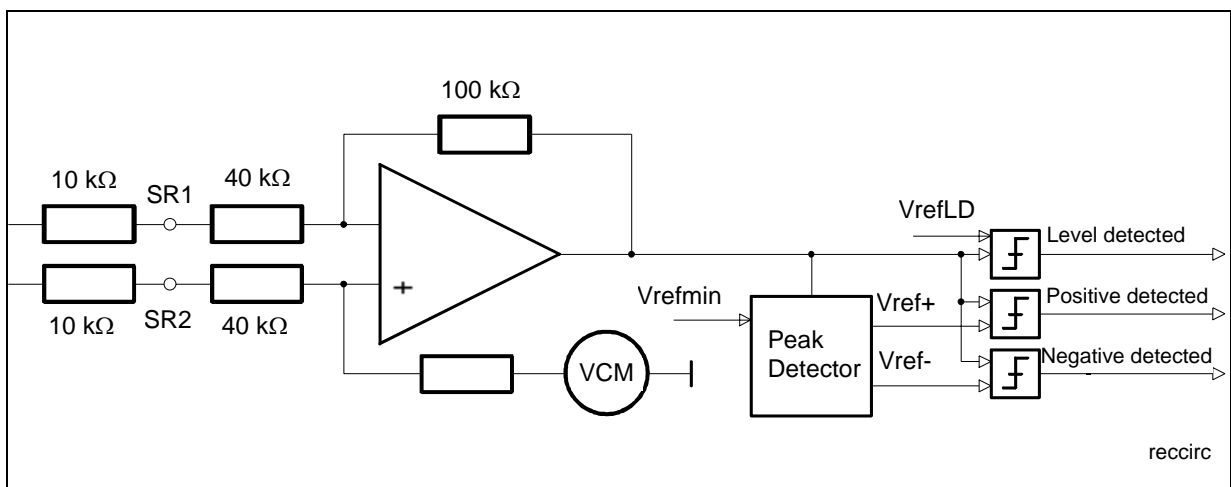

Figure 21 Equivalent Internal Circuit of the Receiver Stage

The input stage works together with external 10 kΩ resistors to match the input voltage to the internal thresholds. The data detection threshold V_{ref} is continuously adapted between a maximal (V_{refmax}) and a minimal (V_{refmin}) reference level related to the line level. The peak detector requires maximum 2 μs to reach the peak value while storing the peak level for at least 250 μs ($RC > 1$ ms).

The additional level detector for power up/down control works with a fixed thresholds V_{refLD} . The level detector monitors the line input signals to detect whether an INFO is present. When closing an analog loop it is therefore possible to indicate an incoming signal during activated loop.

3.3.6 S/T Interface Circuitry

For both, receive and transmit direction a 1:1 transformer is used to connect the ISAC-SX TE transceiver to the 4 wire S/T interface. Typical transformer characteristics can be found in the chapter on electrical characteristics. The connections of the line transformers is shown in **Figure 22**.

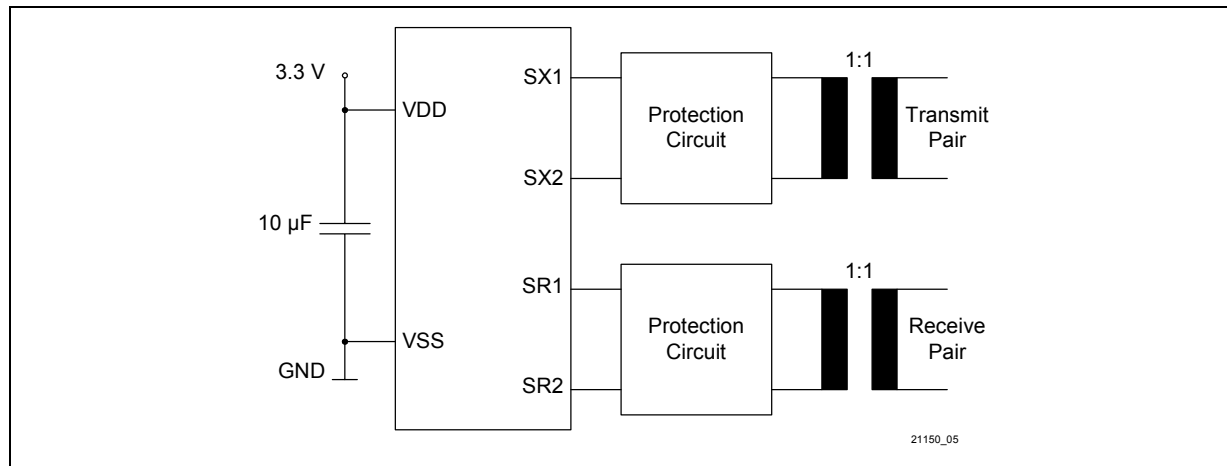

Figure 22 Connection of Line Transformers and Power Supply to the ISAC-SX TE

For the transmit direction an external transformer is required to provide isolation and pulse shape according to the ITU-T recommendations.

3.3.6.1 External Protection Circuitry

The ITU-T I.430 specification for both transmitter and receiver impedances in TEs results in a conflict with respect to external S-protection circuitry requirements:

- To avoid destruction or malfunction of the S-device it is desirable to drain off even small overvoltages reliably.
- To meet the 96 kHz impedance test specified for transmitters and receivers (for TEs only, ITU-T I.430 sections 8.5.1.2a and 8.6.1.1) the protection circuit must be dimensioned such that voltages below 1.2 V (ITU-T I.430 amplitude) x transformer ratio are not affected.

This requirement results from the fact that this test is also to be performed with no supply voltage being connected to the TE. Therefore the second reference point for overvoltages V_{DD} , is tied to GND. Then, if the amplitude of the 96 kHz test signal is greater than the combined forward voltages of the diodes, a current exceeding the specified one may pass the protection circuit.

The following recommendations aim at achieving the highest possible device protection against overvoltages while still fulfilling the 96 kHz impedance tests.

Protection Circuit for Transmitter

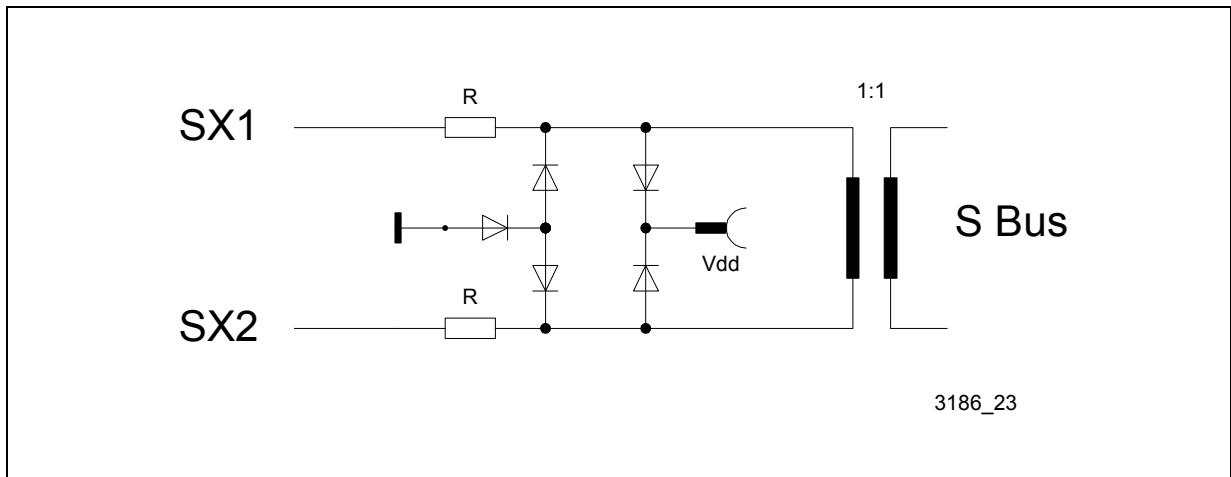

Figure 23 External Circuitry for Transmitter

Figure 23 illustrates the secondary protection circuit recommended for the transmitter. The external resistors ($R = 5 \dots 10 \Omega$) are required in order to adjust the output voltage to the pulse mask on the one hand and in order to meet the output impedance of minimum 20Ω (transmission of a binary zero according to ITU-T I.430) on the other hand.

Two mutually reversed diode paths protect the device against positive or negative overvoltages on both lines.

An ideal protection circuit should limit the voltage at the SX pins from -0.4 V to $V_{DD} + 0.4 \text{ V}$. With the circuit in **Figure 23** the pin voltage range is increased from -1.4 V to $V_{DD} + 0.7 \text{ V}$. The resulting forward voltage of 1.4 V will prevent the protection circuit from becoming active if the 96 kHz test signal is applied while no supply voltage is present.

Protection Circuit for Receiver

Figure 24 illustrates the external circuitry used in combination with a symmetrical receiver. Protection of symmetrical receivers is rather simple.

Description of Functional Blocks

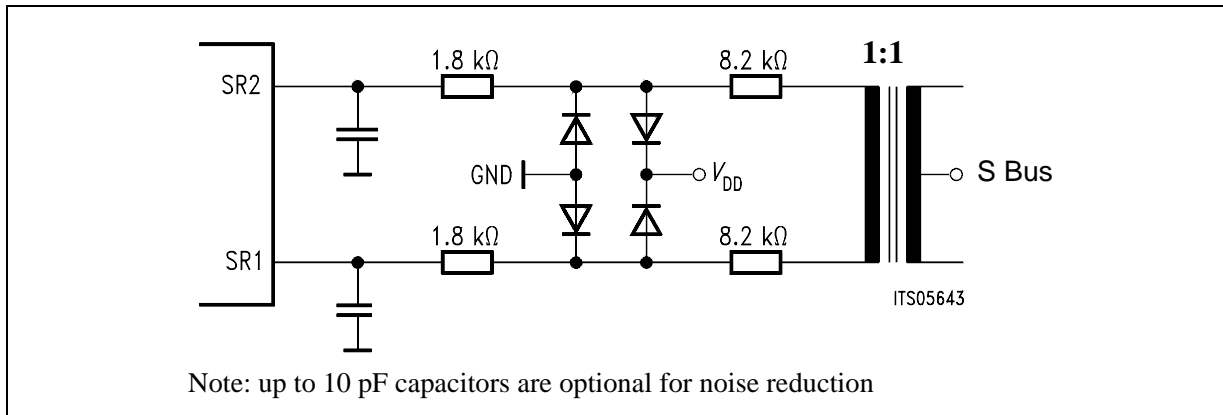

Figure 24 External Circuitry for Symmetrical Receivers

Between each receive line and the transformer a 10 kΩ resistor is used. This value is split into two resistors: one between transformer and protection diodes for current limiting during the 96 kHz test, and the second one between input pin and protection diodes to limit the maximum input current of the chip.

With symmetrical receivers no difficulties regarding LCL measurements are observed; compensation networks thus are obsolete.

In order to comply to the physical requirements of ITU-T recommendation I.430 and considering the national requirements concerning overvoltage protection and electromagnetic compatibility (EMC), the ISAC-SX TE may need additional circuitry.

3.3.6.2 S-Transceiver Synchronization

Synchronization problems can occur on a S-Bus that is not terminated properly. Therefore, it is recommended to change the resistor values in the receive path. The sum of both resistors is increased from 10 k Ω (1.8 + 8.2) to e.g. 34 k Ω (6.8 + 27) for either receiver line. This change is possible but not necessary for a S-Bus that is terminated properly.

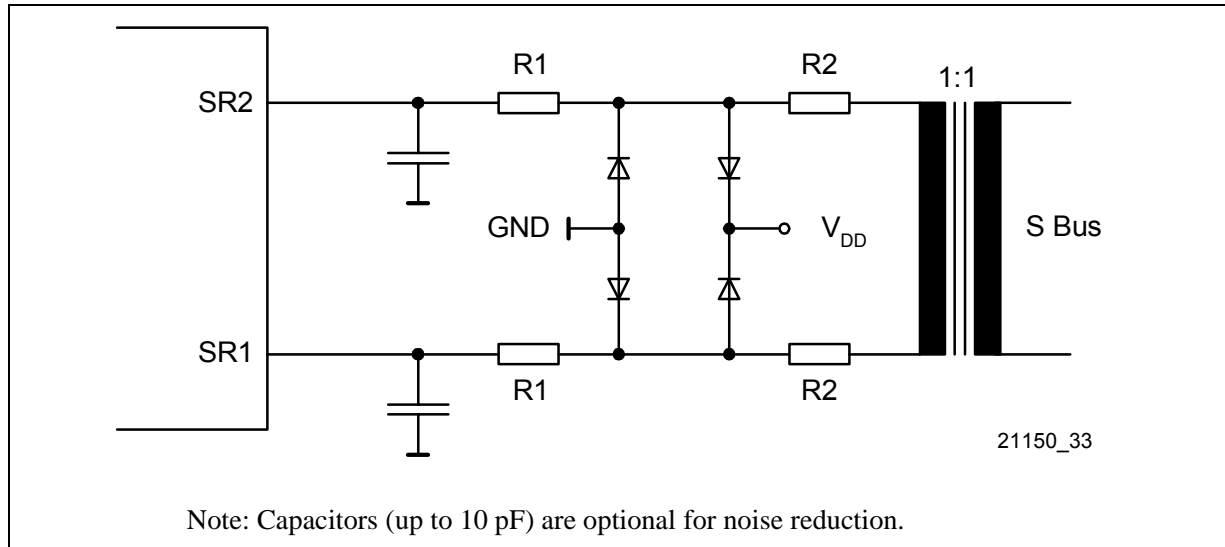

Figure 25 External Circuitry for Symmetrical Receivers

Note: Lower or higher values than 34 k Ω may be used as well, however for values above 34 k Ω the additional delay must be compensated by setting TR_CONF2.PDS=1 (compensates 260 ns) so the allowed input phase delay is not violated.

3.3.7 S/T Interface Delay Compensation

The S/T transmitter is shifted by two S/T bits minus 7 oscillator periods (plus analog delay plus delay of the external circuitry) with respect to the received frame. To compensate additional delay introduced into the receive and transmit path by the external circuit the delay of the transmit data can be reduced by another two oscillator periods (2 x 130 ns). Therefore PDS of the TR_CONF2 register must be programmed to '1'. This delay compensation might be necessary in order to comply with the "total phase deviation input to output" requirement of ITU-T recommendation I.430 which specifies a phase deviation in the range of - 7% to + 15% of a bit period.

3.3.8 Level Detection Power Down

If MODE1.CFS is set to '0', the clocks are also provided in power down state, whereas if CFS is set to '1' only the analog level detector is active in power down state. All clocks, including the IOM-2 interface, are stopped (DD, DU are 'high', DCL and BCL are 'low').

Description of Functional Blocks

An activation initiated from the exchange side will have the consequence that a clock signal is provided automatically if TR_CONF0.LDD is set to '0'. If TR_CONF0.LDD is set to '1' the microcontroller has to take care of an interrupt caused by the level detect circuit (ISTATR.LD)

From the terminal side an activation must be started by setting and resetting the SPU-bit in the IOM_CR register and writing TIM to the CIX0 register or by resetting MODE1.CFS=0.

3.3.9 Transceiver Enable/Disable

The layer-1 part of the ISAC-SX TE can be enabled/disabled by configuration (see [Figure 26](#)) with the two bits TR_CONF0.DIS_TR and TR_CONF2.DIS_TX .

By default all layer-1 functions with the exception of the transmitter buffer is enabled (DIS_TR = '0', DIS_TX = '1'). With several terminals connected to the S/T interface, another terminal may keep the interface activated although the ISAC-SX TE does not establish a connection. The receiver will monitor for incoming calls in this configuration. If the transceiver is disabled (DIS_TR = '1') all layer-1 functions are disabled including the level detection circuit of the receiver. In this case the power consumption of the Layer-1 is reduced to a minimum. The HDLC controller can still operate via IOM-2. The DCL and FSC pins become input.

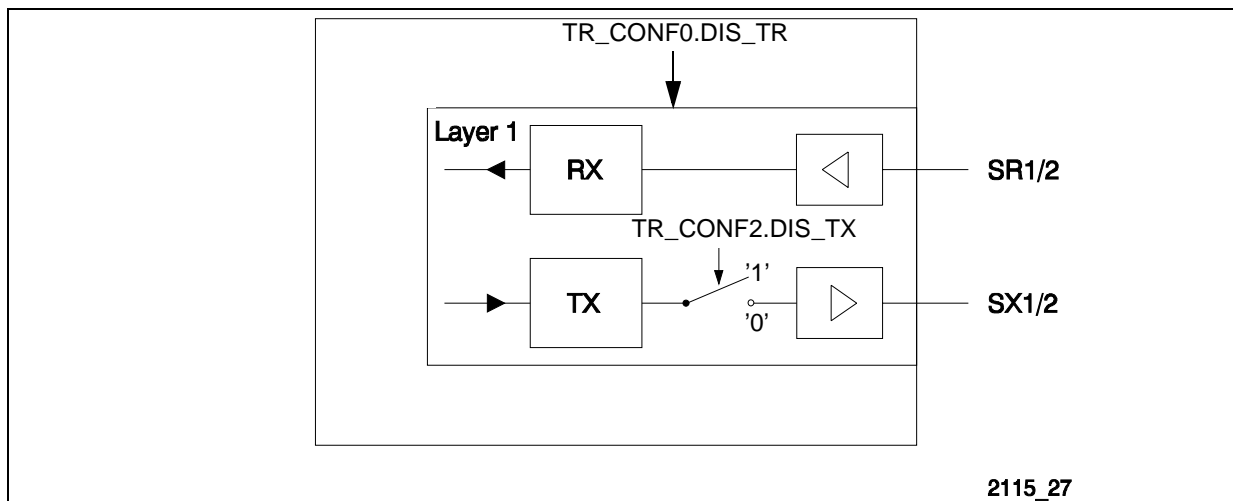

Figure 26 Disabling of S/T Transmitter

3.3.10 Test Functions

The ISAC-SX TE provides test and diagnostic functions for the S/T interface:

Note: For more details please refer to the application note "Test Function of new S-Transceiver family"

- The **internal local loop** (internal Loop A) is activated by a C/I command ARL. The transmit data of the transmitter is looped back internally to the receiver. The data of the IOM-2 input B- and D-channels are looped back to the output B- and D-channels. The S/T interface level detector is enabled, i.e. if a level is detected this will be reported by the Resynchronization Indication (RSY) but the loop function is not affected. Depending on the DIS_TX bit in the TR_CONF2 register the internal local loop can be transparent or non transparent to the S/T line.
- The **external local loop** (external Loop A) is activated in the same way as the internal local loop described above. Additionally the EXLP bit in the TR_CONF0 register has to be programmed and the loop has to be closed externally as described in [Figure 27](#). The S/T interface level detector is disabled. This allows complete system diagnostics.
- In **remote line loop** (RLP) received data is looped back to the S/T interface. The D-channel information received from the line card is transparently forwarded to the output IOM-2 D-channel. The output B-channel information on IOM-2 is fixed to 'FF'_H while this test loop is active. The remote loop is programmable in TR_CONF2.RLP.

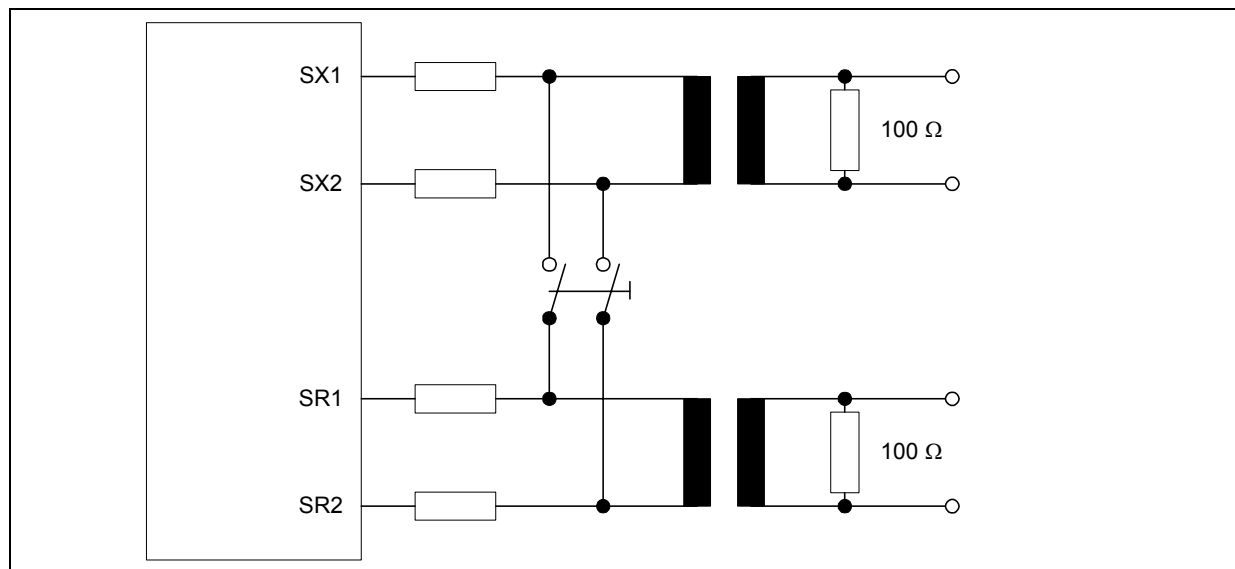

Figure 27 External Loop at the S/T-Interface

Description of Functional Blocks

- transmission of special test signals on the S/T interface according to the modified AMI code are initiated via a C/I command written in CIX0 register (see [Chapter 3.5.2](#))

Two kinds of test signals may be transmitted by the ISAC-SX:

- The single pulses are of alternating polarity. One pulse is transmitted in each frame resulting in a frequency of the fundamental mode of 2 kHz. The corresponding C/I command is SSP (Send Single Pulses).
- The continuous pulses are of alternating polarity. 48 pulses are transmitted in each frame resulting in a frequency of the fundamental mode of 96 kHz. The corresponding C/I command is SCP (Send Continuous Pulses).

3.4 Clock Generation

Figure 28 shows the clock system of the ISAC-SX TE. The oscillator is used to generate a 7.68 MHz clock signal (f_{XTAL}). The DPLL generates the IOM-2 clocks FSC (8 kHz), DCL (1536 kHz) and BCL (768 kHz) synchronous to the received S/T frames.

The FSC signal is used to generate the pulse lengths of the different reset sources C/I Code, \overline{EAW} pin and Watchdog (see **Chapter 3.2.4**). The IOM-2 clocks are summarized in **Table 9**.

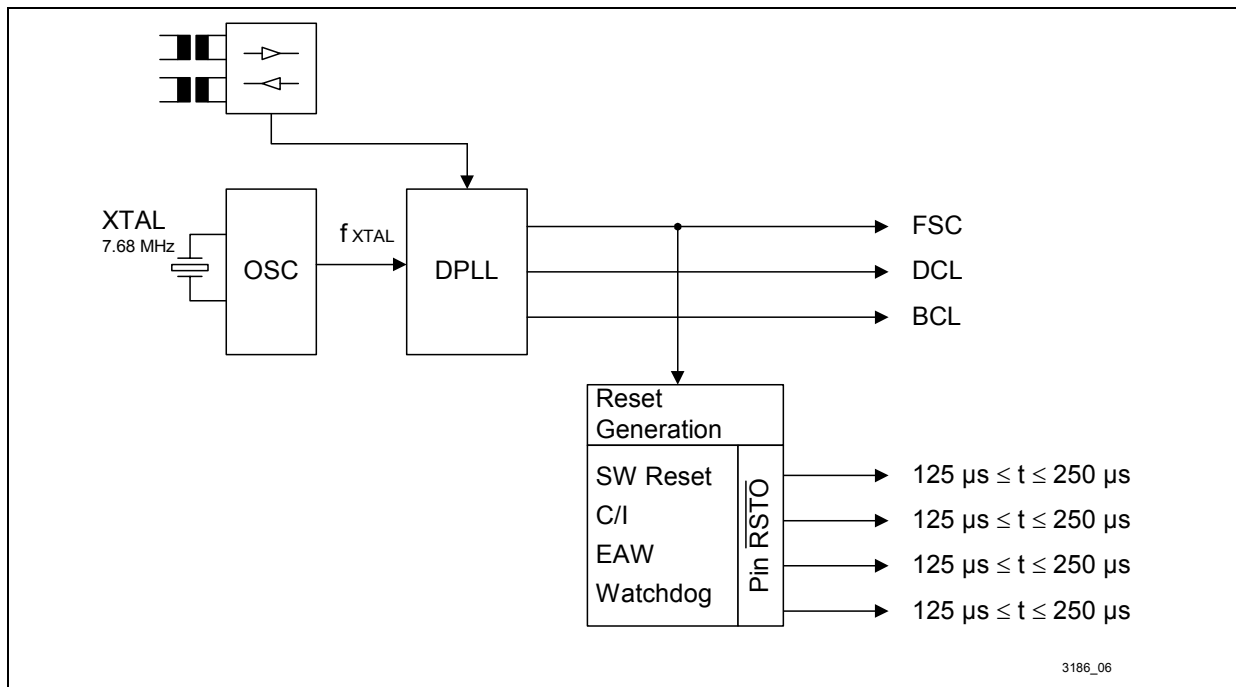

Figure 28 Clock System of the ISAC-SX TE

Table 9 IOM-2 Clocks

Signal	Function
FSC	o:8 kHz (DIS_TR=0), normal mode i:8 kHz (DIS_TR=1), S transceiver disabled *1)
DCL	o:1536 kHz (DIS_TR=0), normal mode i:1536/768 kHz (DIS_TR=1), S transceiver disabled *1)
BCL	o:768 kHz
DU	i *2)
DD	o *2)

Note: *i* = input; *o* = output;

1) The S transceiver can be disabled ($TR_CONF0.DIS_TR=1$) so the IOM clocks become inputs and with $IOM_CR.CLKM$ the DCL input can be selected to double clock (0) or single bit clock (1).

2) The direction input/output refers to the direction of the B- and D-channel data stream across the S-transceiver. Due to the capabilities of the IOM-2 handler the direction of some other timeslots may be different if this is programmed by the host (e.g. for data exchange between different devices connected to IOM-2).

3.4.1 Description of the Receive PLL (DPLL)

The receive PLL performs phase tracking between the F/L transition of the receive signal and the recovered clock. Phase adjustment is done by adding or subtracting 0.5 or 1 XTAL period to or from a 1.536-MHz clock cycle. The 1.536-MHz clock is then used to generate any other clock synchronized to the line.

During (re)synchronization an internal reset condition may effect the 1.536-MHz clock to have high or low times as short as 130 ns. After the S/T interface frame has achieved the synchronized state (after three consecutive valid pairs of code violations) the FSC output is set to a specific phase relationship, thus causing once an irregular FSC timing.

The phase relationships of the clocks are shown in [Figure 29](#).

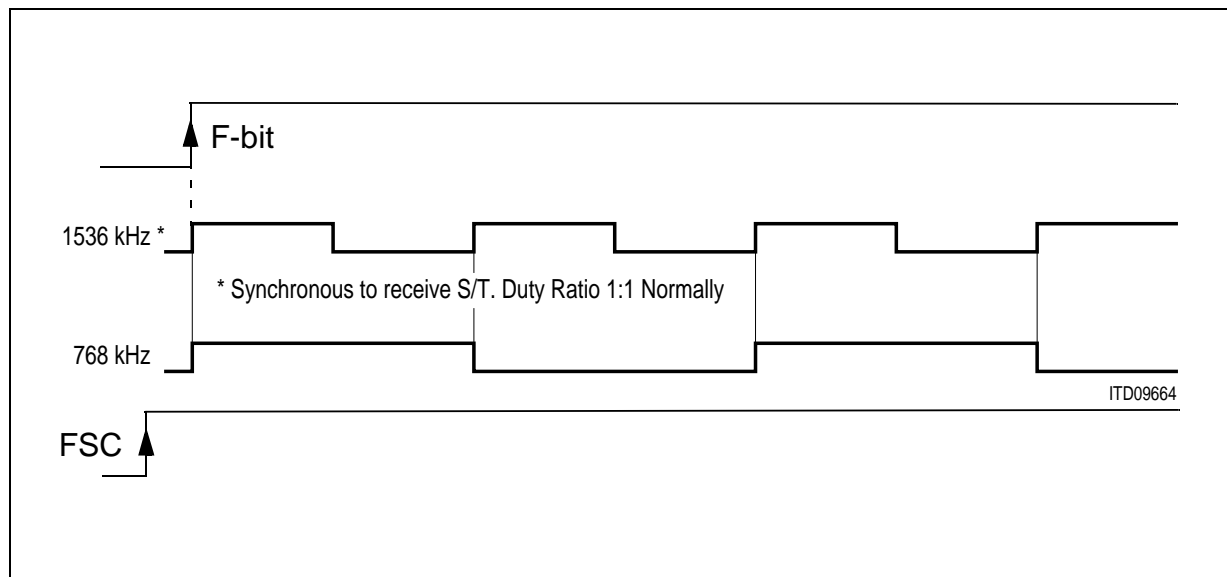

Figure 29 Phase Relationships of ISAC-SX TE Clock Signals

3.4.2 Jitter

The timing extraction jitter of the ISAC-SX TE conforms to ITU-T Recommendation I.430 (– 7% to + 7% of the S-interface bit period).

3.4.3 Oscillator Clock Output C768

The ISAC-SX TE derives its system clocks from an external clock connected to XTAL1 (while XTAL2 is not connected) or from a 7.68 MHz crystal connected across XTAL1 and XTAL2.

At pin C768 a buffered 7.68 MHz output clock is provided to drive further devices, which is suitable in multiline applications for example (see [Figure 30](#)). This clock is not synchronized to the S-interface.

In power down mode the C768 output is disabled (low signal).

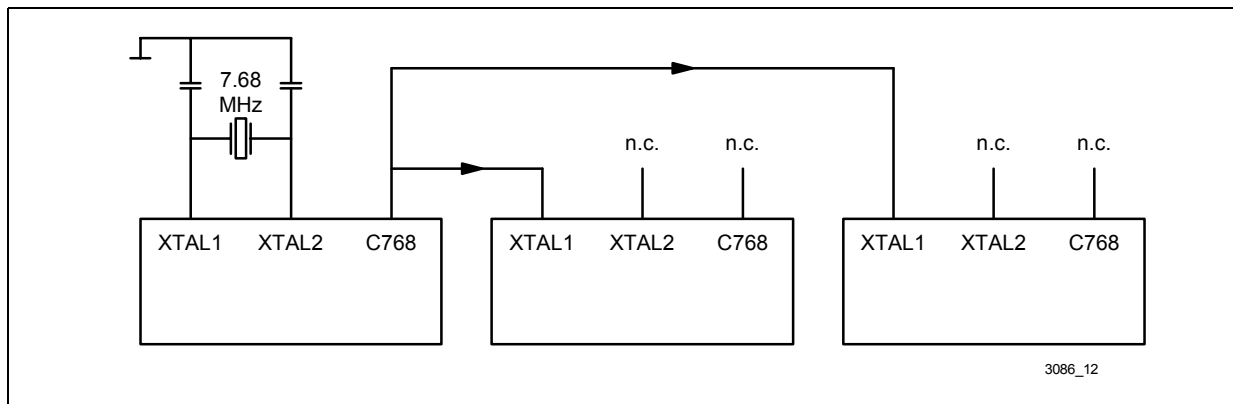

Figure 30 Buffered Oscillator Clock Output

3.5 Control of Layer-1

The layer-1 activation / deactivation is controlled by an internal state machine via the IOM-2 C/I0 channel. The ISAC-SX TE layer-1 control flow is shown in [Figure 31](#).

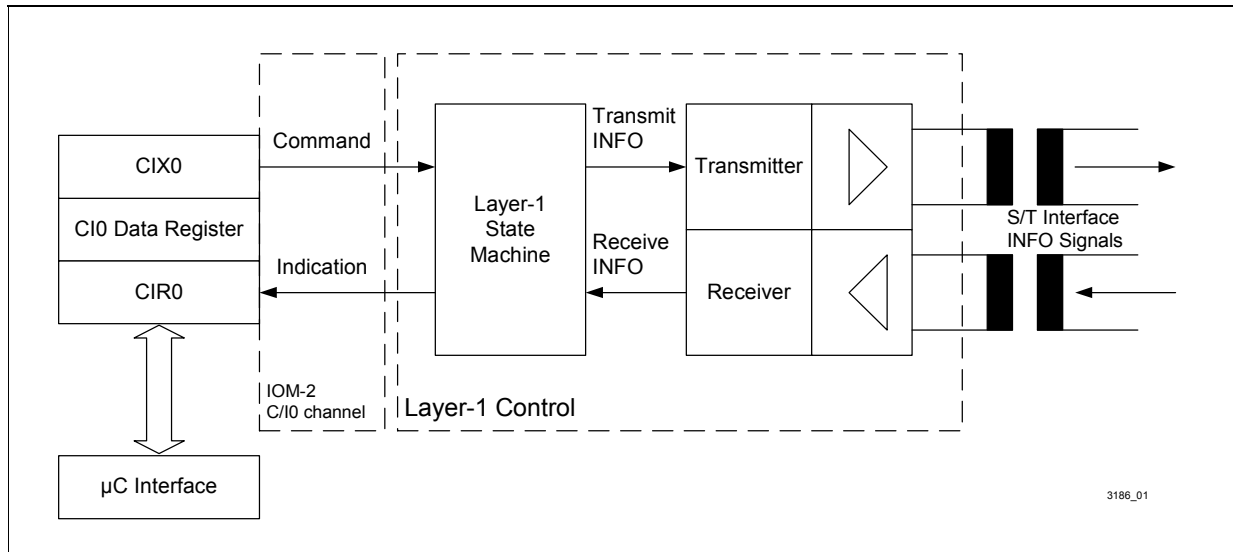

Figure 31 Layer-1 Control

In the following sections the layer-1 control by the ISAC-SX TE state machine will be described. For the description of the IOM-2 C/I0 channel see also [Chapter 3.7.4](#).

The layer-1 functions are controlled by commands issued via the CIX0 register. These commands, sent over the IOM-2 C/I channel 0 to layer 1, trigger certain procedures, such as activation/deactivation, switching of test loops and transmission of special pulse patterns. These procedures are governed by layer-1 state diagrams. Responses from layer 1 are obtained by reading the CIR0 register after a CIC interrupt (ISTA).

The state diagrams of the ISAC-SX TE are shown in [Figure 33](#) and [Figure 34](#). The activation/deactivation implemented by the ISAC-SX TE agrees with the requirements set forth in ITU recommendations. State identifiers F1-F8 are in accordance with ITU I.430.

State machines are the key to understanding the transceiver part of the ISAC-SX TE. They include all information relevant to the user and enable him to understand and predict the behaviour of the ISAC-SX TE. The state diagram notation is given in [Figure 32](#). The informations contained in the state diagrams are:

- state name (based on ITU I.430)
- S/T signal transmitted (INFO)
- C/I code received
- C/I code transmitted
- transition criteria

The coding of the C/I commands and indications are described in detail in [Chapter 3.5.2](#).

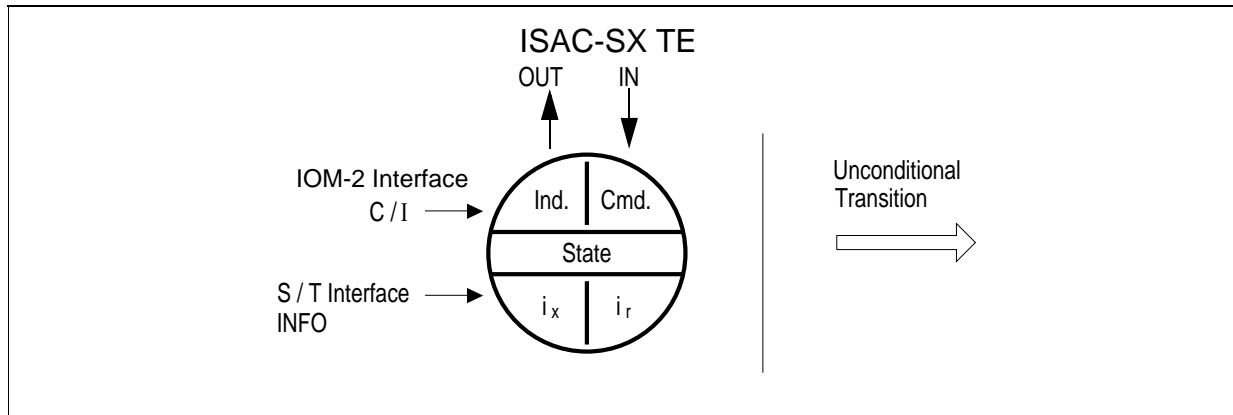

Figure 32 State Diagram Notation

The following example illustrates the use of a state diagram with an extract of the TE state diagram. The state explained is “F3 deactivated”.

The state may be entered:

- from the unconditional states (ARL, RES, TM)
- from state “F3 pending deactivation”, “F3 power up”, “F4 pending activation” or “F5 unsynchronized” after the C/I command “DI” has been received.

The following informations are transmitted:

- INFO 0 (no signal) is sent on the S/T-interface.

C/I message “DC” is issued on the IOM-2 interface.

The state may be left by either of the following methods:

- Leave for the state “F3 power up” in case C/I = “TIM” code is received.
- Leave for state “F4 pending activation” in case C/I = AR8 or AR10 is received.
- Leave for the state “F6 synchronized” after INFO 2 has been recognized on the S/T-interface.
- Leave for the state “F7 activated” after INFO 4 has been recognized on the S/T-interface.
- Leave for any unconditional state if any unconditional C/I command is received.

As can be seen from the transition criteria, combinations of multiple conditions are possible as well. A “*” stands for a logical AND combination. And a “+” indicates a logical OR combination.

The sections following the state diagram contain detailed information on all states and signals used.

3.5.1 State Machine TE Mode

3.5.1.1 State Transition Diagram (TE)

Figure 33 shows the state transition diagram of the ISAC-SX TE state machine.
Figure 34 shows this for the unconditional transitions (Reset, Loop, Test Mode i).

Description of Functional Blocks

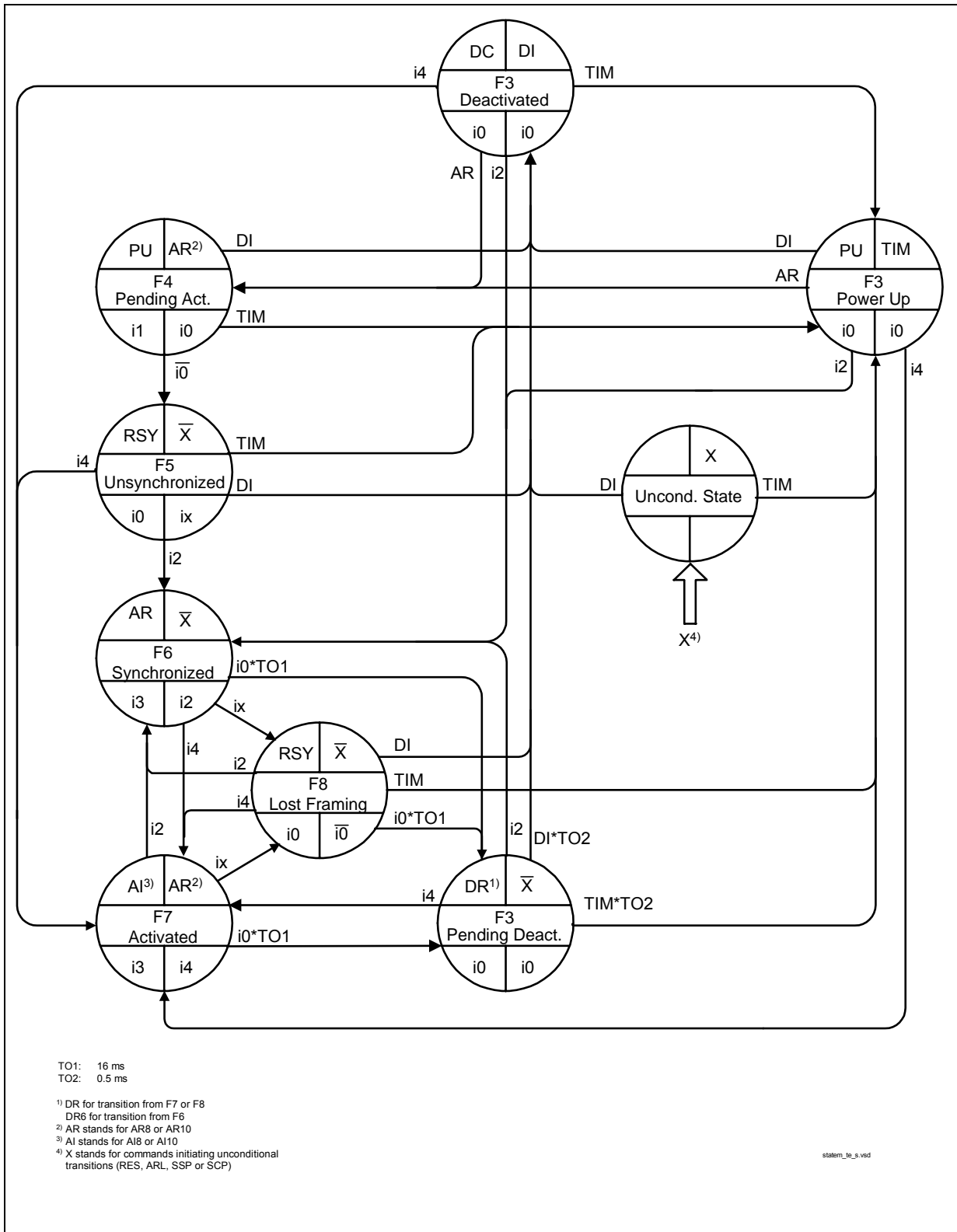

Figure 33 State Transition Diagram (TE)

Description of Functional Blocks

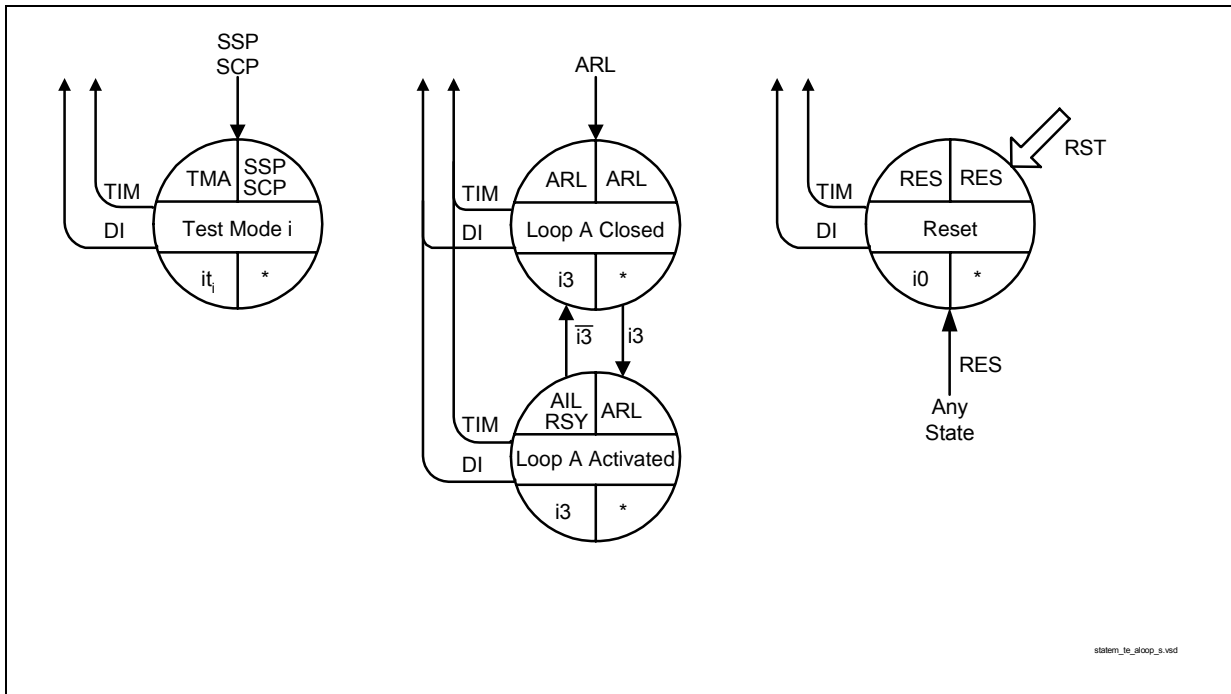

Figure 34 State Transition Diagram of Unconditional Transitions (TE)

3.5.1.2 States (TE)

F3 Pending Deactivation

State after deactivation from the S/T interface by info 0. Note that no activation from the terminal side is possible starting from this state. A 'DI' command has to be issued to enter the state 'Deactivated State'.

F3 Deactivated State

The S/T interface is deactivated and the clocks are deactivated 500 μs after entering this state and receiving info 0 if the CFS bit of the ISAC-SX TE Configuration Register is set to "0". Activation is possible from the S/T interface and from the IOM-2 interface.

F3 Power Up

The S/T interface is deactivated (info 0 on the line) and the clocks are running.

F4 Pending Activation

The ISAC-SX transmits info 1 towards the network, waiting for info 2.

F5 Unsynchronized

Any signal except info 2 or 4 detected on the S/T interface.

F6 Synchronized

The receiver has synchronized and detects info 2. Info 3 is transmitted to synchronize the NT.

Description of Functional Blocks**F7 Activated**

The receiver has synchronized and detects info 4. All user channels are now conveyed transparently to the IOM-2 interface.

To transfer user channels transparently to the S/T interface either the command AR8 or AR10 has to be issued and the signal from remote side must be synchronous.

F8 Lost Framing

The receiver has lost synchronization in the states F6 or F7 respectively.

Unconditional States**Loop A Closed (internal or external)**

The ISAC-SX loops back the transmitter to the receiver and activates by transmission of info 3. The receiver has not yet synchronized.

For a non transparent internal loop the DIS_TX bit of register TR_CONF2 has to be set to '1'.

Loop A Activated (internal or external)

The receiver has synchronized to info 3. Data may be sent. The indication "AIL" is output to indicate the activated state. If the loop is closed internally and the S/T line awake detector detects any signal on the S/T interface, this is indicated by "RSY".

Test Mode - SSP

Single alternating pulses are transmitted to the S/T-interface resulting in a frequency of the fundamental mode of 2 kHz.

Test Mode - SCP

Continuous alternating pulses are transmitted to the S/T-interface resulting in a frequency of the fundamental mode of 96 kHz.

Description of Functional Blocks

3.5.1.3 C/I Codes (TE)

Command	Abbr.	Code	Remark
Activation Request with priority class 8	AR8	1000	Activation requested by the ISAC-SX, D-channel priority set to 8 (see note)
Activation Request with priority class 10	AR10	1001	Activation requested by the ISAC-SX, D-channel priority set to 10 (see note)
Activation Request Loop	ARL	1010	Activation requested for the internal or external Loop A (see note). For a non transparent internal loop bit DIS_TX of register TR_CONF2 has to be set to '1' additionally.
Deactivation Indication	DI	1111	Deactivation Indication
Reset	RES	0001	Reset of the layer-1 statemachine
Timing	TIM	0000	Layer-2 device requires clocks to be activated
Test mode SSP	SSP	0010	One AMI-coded pulse transmitted in each frame, resulting in a frequency of the fundamental mode of 2 kHz
Test mode SCP	SCP	0011	AMI-coded pulses transmitted continuously, resulting in a frequency of the fundamental mode of 96 kHz

Note: In the activated states (AI8, AI10 or AIL indication) the 2B+D channels are only transferred transparently to the S/T interface if one of the three "Activation Request" commands is permanently issued.

Description of Functional Blocks

Indication	Abbr.	Code	Remark
Deactivation Request	DR	0000	Deactivation request via S/T-interface if left from F7/F8
Reset	RES	0001	Reset acknowledge
Test Mode Acknowledge	TMA	0010	Acknowledge for both SSP and SCP
Slip Detected	SLD	0011	
Resynchronization during level detect	RSY	0100	Signal received, receiver not synchronous
Deactivation Request from F6	DR6	0101	Deactivation Request from state F6
Power up	PU	0111	IOM-2 interface clocking is provided
Activation request	AR	1000	Info 2 received
Activation request loop	ARL	1010	Internal or external loop A closed
Illegal Code Violation	CVR	1011	Illegal code violation received. This function has to be enabled by setting the EN_ICV bit of register TR_CONF0.
Activation indication loop	AIL	1110	Internal or external loop A activated
Activation indication with priority class 8	AI8	1100	Info 4 received, D-channel priority is 8 or 9.
Activation indication with priority class 10	AI10	1101	Info 4 received, D-channel priority is 10 or 11.
Deactivation confirmation	DC	1111	Clocks are disabled if CFS bit of register MODE1 is set to '1', quiescent state

Description of Functional Blocks

3.5.1.4 Infos on S/T (TE)

Receive Infos on S/T (Downstream)

Name	Abbr.	Description
info 0	i0	No signal on S/T
info 2	i2	4 kHz frame A='0'
info 4	i4	4 kHz frame A='1'
info X	ix	Any signal except info 2 or info 4

Transmit Infos on S/T (Upstream)

Name	Abbr.	Description
info 0	i0	No signal on S/T
info 1	i1	Continuous bit sequence of the form '00111111'
info 3	i3	4 kHz frame
Test info 1	it ₁	SSP - Send Single Pulses
Test info 2	it ₂	SCP - Send Continuous Pulses

Description of Functional Blocks

3.5.2 Command/ Indicate Channel Codes (C/I0) - Overview

The table below presents all defined C/I0 codes. A command needs to be applied continuously until the desired action has been initiated. Indications are strictly state orientated. Refer to the state diagrams in the previous sections for commands and indications applicable in various states.

Code				TE Mode	
				Cmd	Ind
0	0	0	0	TIM	DR
0	0	0	1	RES	RES
0	0	1	0	SSP	TMA
0	0	1	1	SCP	SLD
0	1	0	0	–	RSY
0	1	0	1	–	DR6
0	1	1	0	–	–
0	1	1	1	–	PU
1	0	0	0	AR8	AR
1	0	0	1	AR10	–
1	0	1	0	ARL	ARL
1	0	1	1	–	CVR
1	1	0	0	–	AI8
1	1	0	1	–	AI10
1	1	1	0	–	AIL
1	1	1	1	DI	DC

3.6 Control Procedures

3.6.1 Example of Activation/Deactivation

An example of an activation/deactivation of the S/T interface initiated by the terminal with the time relationships mentioned in the previous chapters is shown in **Figure 35**.

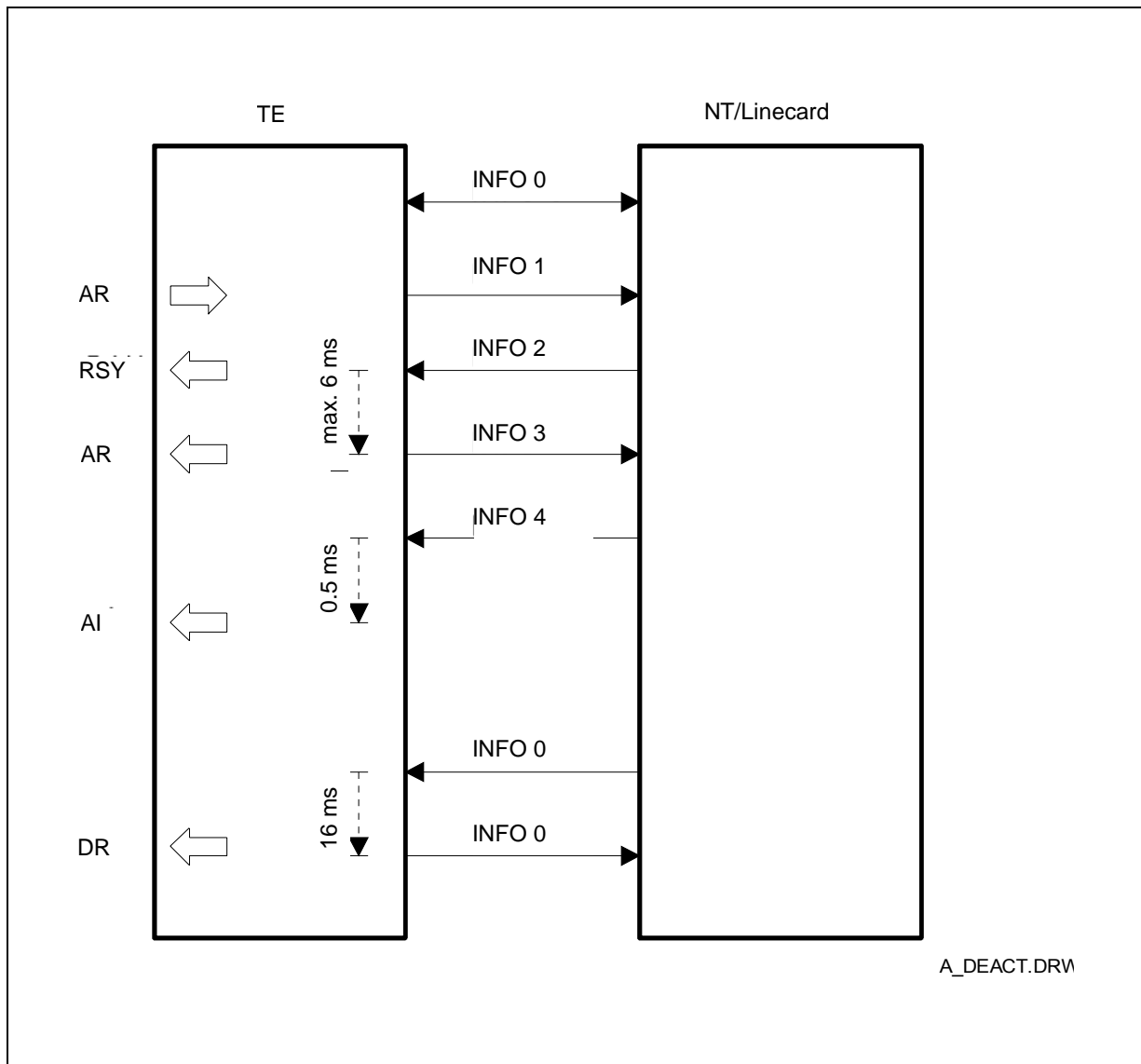

Figure 35 Example of Activation/Deactivation Initiated by the Terminal

3.7 IOM-2 Interface

The ISAC-SX TE supports the IOM-2 interface in terminal mode with single clock and double clock. The IOM-2 interface consists of four lines: FSC, DCL, DD and DU. Another clock signal BCL provides a single bit clock. The rising edge of FSC indicates the start of an IOM-2 frame. The DCL and the BCL clock signals synchronize the data transfer on both data lines DU and DD. The DCL is twice the bit rate, the BCL rate is equal to the bit rate. The bits are shifted out with the rising edge of the first DCL clock cycle and sampled at the falling edge of the second clock cycle.

The IOM-2 interface can be enabled/disabled with the DIS_IOM bit in the IOM_CR register.

The IOM clock signals are generated by the receive DPLL which synchronizes the FSC to the received S/T frame.

The BCL clock together with the serial data strobe signals SDS can be used to connect timeslot oriented standard devices to the IOM-2 interface. If the transceiver is disabled (TR_CON.DIS_TR) the DCL and FSC pins become input and the HDLC part can still work via IOM-2. In this case the clock mode bit (IOM_CR.CLKM) selects between a double clock and a single clock input for DCL.

The clock rate/frequency of the IOM-2 signals in TE mode are:

DD, DU: 768 kbit/s

FSC (o): 8 kHz

DCL (o): 1536 kHz (double clock rate)

BCL (o): 768 kHz (single clock rate)

Option - Transceiver disabled (DIS_TR = '1'):

FSC (i): 8 kHz

DCL (i): 1536 ... 4096 kHz, in steps of 512 kHz (double clock rate)

IOM-2 Frame Structure (TE Mode)

The frame structure on the IOM-2 data ports (DU,DD) of a master device in IOM-2 terminal mode is shown in **Figure 36**.

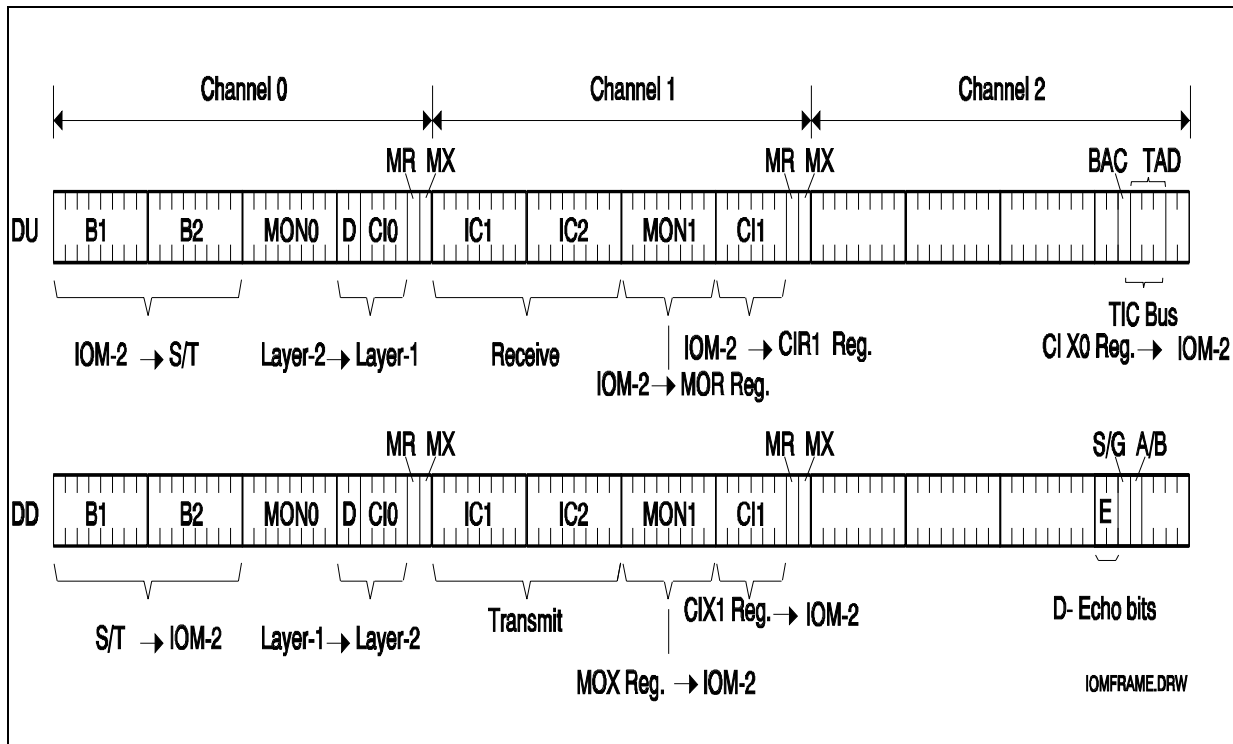

Figure 36 IOM[®]-2 Frame Structure in Terminal Mode

The frame is composed of three channels

- Channel 0 contains 144-kbit/s of user and signaling data (2B + D), a MONITOR programming channel (MON0) and a command/indication channel (CI0) for control and programming of the layer-1 transceiver.
- Channel 1 contains two 64-kbit/s intercommunication channels (IC) plus a MONITOR and command/indicate channel (MON1, CI1) to program or transfer data to other IOM-2 devices.
- Channel 2 is used for the TIC-bus access. Only the command/indicate bits are specified in this channel.

3.7.1 IOM-2 Handler

The IOM-2 handler offers a great flexibility for handling the data transfer between the different functional units of the ISAC-SX TE and voice/data devices connected to the IOM-2 interface. Additionally it provides a microcontroller access to all timeslots of the IOM-2 interface via the four controller data access registers (CDA). **Figure 37** shows the architecture of the IOM-2 handler. For illustrating the functional description it contains all configuration and control registers of the IOM-2 handler. A detailed register description can be found in **Chapter 4.3**.

The PCM data of the functional units

- Transceiver (TR) and the
- Controller data access (CDA)

can be configured by programming the timeslot and data port selection registers (TSDP). With the TSS bits (Timeslot Selection) the PCM data of the functional units can be assigned to each of the 12 PCM timeslots of the IOM-2 frame. With the DPS bit (Data Port Selection) the output of each functional unit is assigned to DU or DD respectively. The input is assigned vice versa. With the data control registers (xxx_CR) the access to the data of the functional units can be controlled by setting the corresponding control bits (EN, SWAP).

The IOM-2 handler also provides access to the

- MONITOR channel (MON)
- C/I channels (C/I0,C/I1)
- TIC bus (TIC) and
- HDLC control

The access to these channels is controlled by the registers MON_CR and DCI_CR.

The IOM-2 interface with the Serial Data Strobe SDS is controlled by the control registers IOM_CR, SDS_CR.

The reset configuration of the ISAC-SX TE IOM-2 handler corresponds to the defined frame structure and data ports of a master device in IOM-2 terminal mode (see **Figure 36**).

Description of Functional Blocks

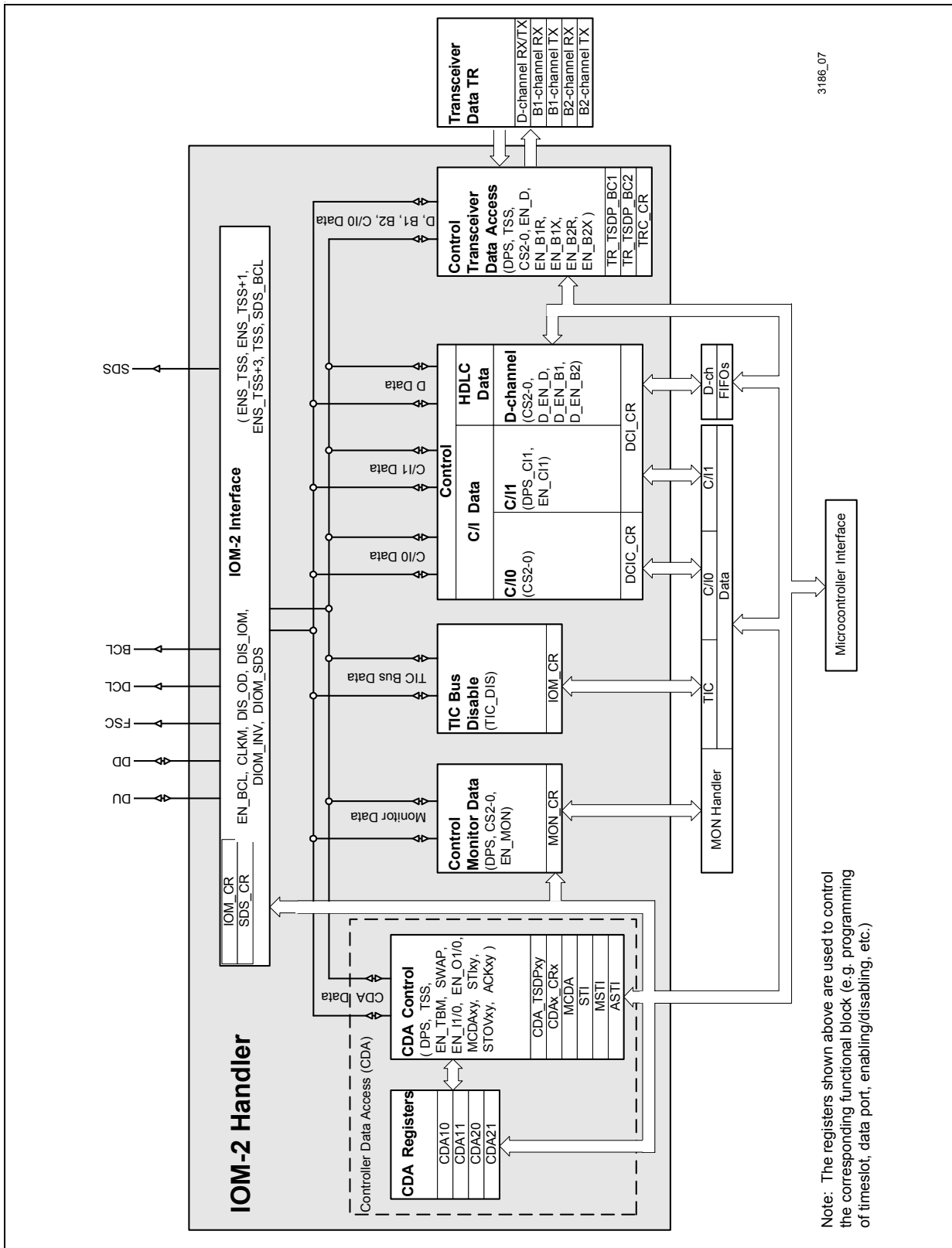

3186_07

Figure 37 Architecture of the IOM Handler (Example Configuration)

3.7.1.1 Controller Data Access (CDA)

With its four controller data access registers (CDA10, CDA11, CDA20, CDA21) the ISAC-SX TE IOM-2 handler provides a very flexible solution for the host access to up to 32 IOM-2 timeslots. However, in the normal mode (DCL output = 1.536 MHz) 12 timeslots are supported. Only if the transceiver is disabled (DIS_TR = '1') and external clocks are provided, up to 32 timeslots (DCL input = 4.096 MHz) can be used.

The functional unit CDA (controller data access) allows with its control and configuration registers

- looping of up to four independent PCM channels from DU to DD or vice versa over the four CDA registers
- shifting of two independent PCM channels to another two independent PCM channels on both data ports (DU, DD). Between reading and writing the data can be manipulated (processed with an algorithm) by the microcontroller. If this is not the case a switching function is performed
- monitoring of up to four timeslots on the IOM-2 interface simultaneously
- microcontroller read and write access to each PCM timeslot

The access principle which is identical for the two channel register pairs CDA10/11 and CDA20/21 is illustrated in [Figure 38](#). Each of the index variables x,y used in the following description can be 1 or 2 for x and 0 or 1 for y. The prefix 'CDA_' from the register names has been omitted for simplification.

To each of the four CDAXy data registers a TSDPxy register is assigned by which the timeslot and the data port can be determined. With the TSS (Timeslot Selection) bits a timeslot from 0...31 can be selected. With the DPS (Data Port Selection) bit the output of the CDAXy register can be assigned to DU or DD, respectively. The timeslot and data port for the output of CDAXy is always defined by its own TSDPxy register. The input of CDAXy depends on the SWAP bit in the control registers CRx.

- If the SWAP bit = '0' (swap is disabled) the timeslot and data port for the input and output of the CDAXy register is defined by its own TSDPxy register.
- If the SWAP bit = '1' (swap is enabled) the input port and timeslot of the CDAX0 is defined by the TSDP register of CDAX1 and the input port and timeslot of CDAX1 is defined by the TSDP register of CDAX0. The input definition for timeslot and data port CDAX0 are thus swapped to CDAX1 and for CDAX1 swapped to CDAX0. The output timeslots are not affected by SWAP.

The input and output of every CDAXy register can be enabled or disabled by setting the corresponding EN (-able) bit in the control register CDAX_CR. If the input of a register is disabled the output value in the register is retained.

Usually one input and one output of a functional unit (transceiver, HDLC controller, CDA register) is programmed to a timeslot on IOM-2 (e.g. for B-channel transmission in upstream direction the HDLC controller writes data onto IOM and the transceiver reads data from IOM). For monitoring data in such cases a CDA register is programmed as

Description of Functional Blocks

described below under “Monitoring Data”. Besides that none of the IOM timeslots must be assigned more than one input and output of any functional unit.

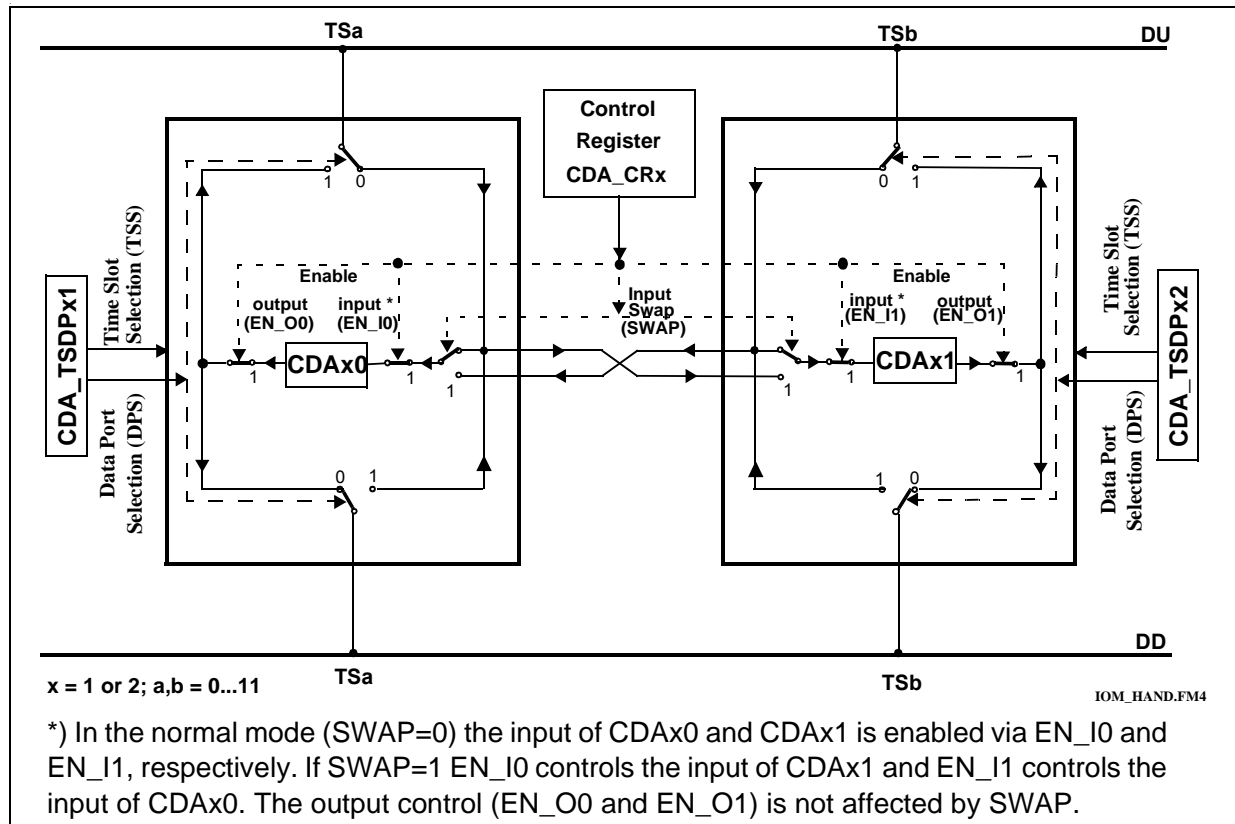

Figure 38 Data Access via CDAX1 and CDAX2 Register Pairs

Looping and Shifting Data

Figure 39 gives examples for typical configurations with the above explained control and configuration possibilities with the bits TSS, DPS, EN and SWAP in the registers TSDPx_y or CDAX_x_CR:

- a) Looping IOM-2 timeslot data from DU to DD or vice versa (SWAP = 0)
- b) Shifting data from TSa to TSb and TSc to TSd in both transmission directions (SWAP = 1)
- c) Switching data from TSa to TSb and looping from DU to DD or TSc to TSd and looping from DD to DU respectively

TSa is programmed in TSDP10, TSb in TSDP11, TSc in TSDP20 and TSd in TSDP21. It should also be noted that the input control of CDA registers is swapped if SWAP=1 while the output control is not affected (e.g. for CDA11 in example a: EN_I1=1 and EN_O1=1, whereas for CDA11 in example b: EN_I0=1 and EN_O1=1).

Description of Functional Blocks

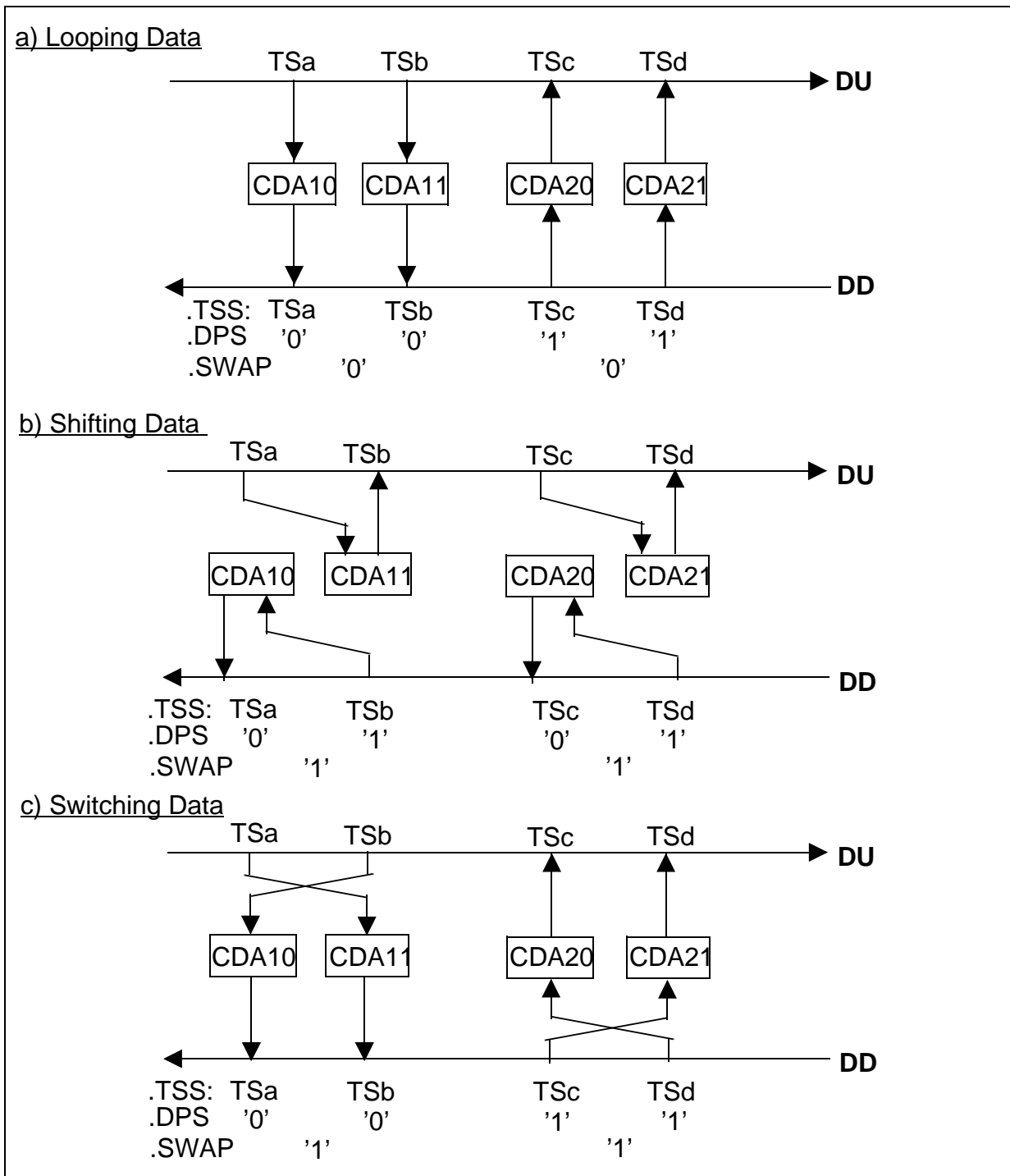

Figure 39 Examples for Data Access via CDAxy Registers

- a) Looping Data
- b) Shifting (Switching) Data
- c) Shifting and Looping Data

Description of Functional Blocks

Figure 40 shows the timing of looping TSa from DU to DD ($a = 0...11$) via CDAXy register. TSa is read in the CDAXy register from DU and is written one frame later on DD.

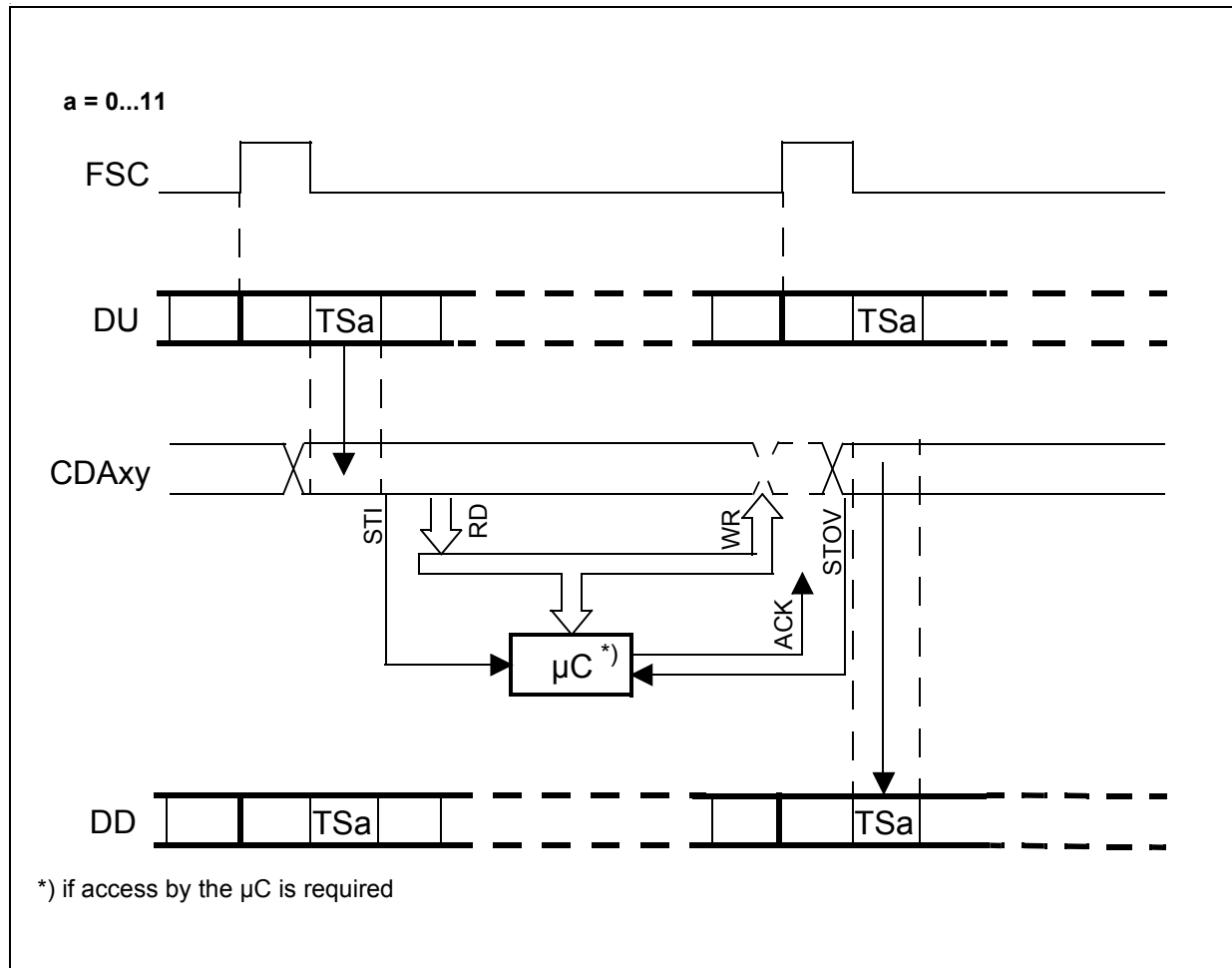

Figure 40 Data Access when Looping TSa from DU to DD

Figure 41 shows the timing of shifting data from TSa to TSb on DU (DD). In **Figure 41a**) shifting is done in one frame because TSa and TSb didn't succeed direct one another ($a, b = 0...9$ and $b \geq a+2$). In **Figure 41b**) shifting is done from one frame to the following frame. This is the case when the timeslots succeed one other ($b = a+1$) or b is smaller than a ($b < a$).

At looping and shifting the data can be accessed by the controller between the synchronous transfer interrupt (STI) and the status overflow interrupt (STOV). STI and STOV are explained in the section 'Synchronous Transfer'. If there is no controller intervention the looping and shifting is done autonomous.

Description of Functional Blocks

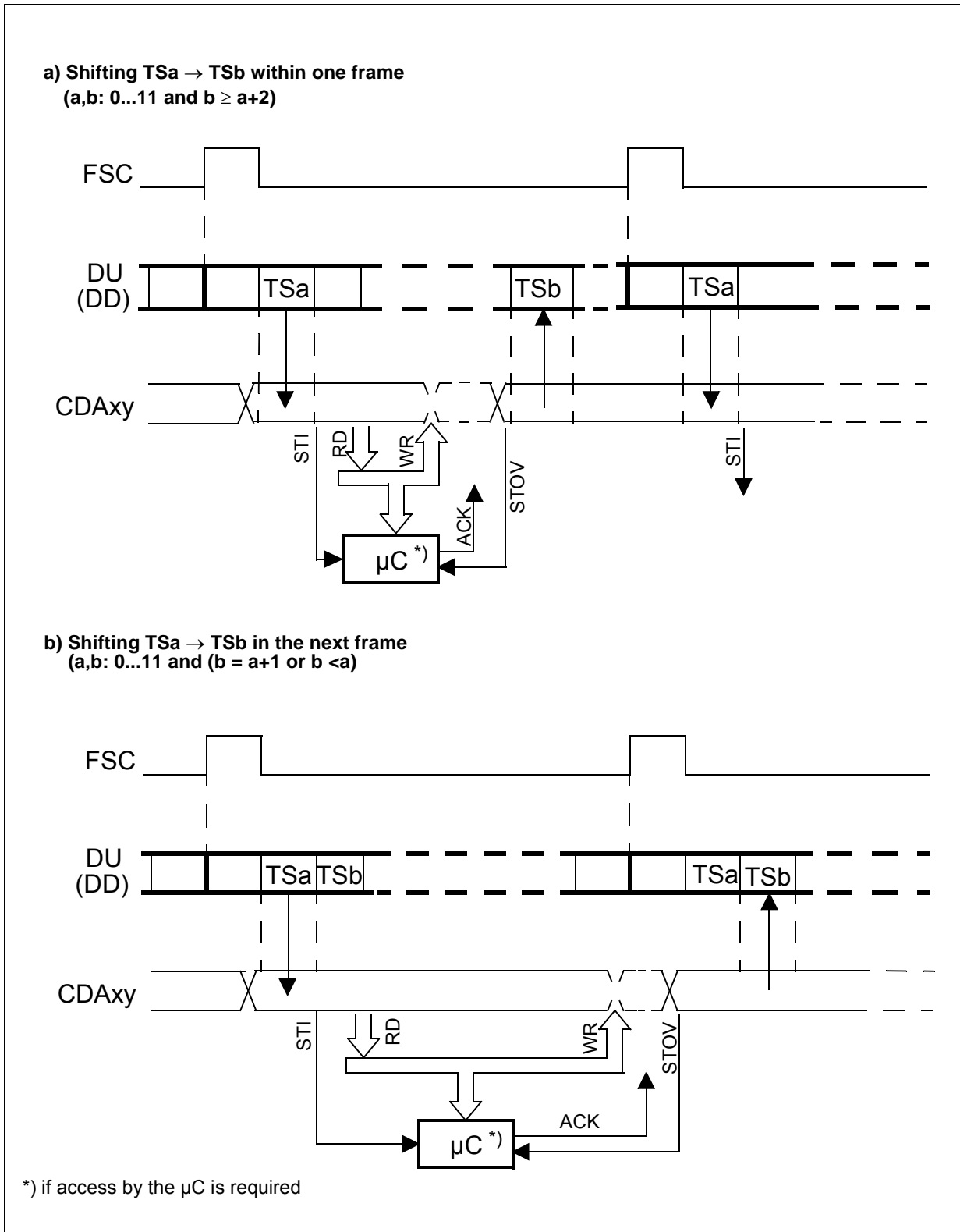

Figure 41 Data Access when Shifting TSa to TSb on DU (DD)

Monitoring Data

Figure 42 gives an example for monitoring of two IOM-2 timeslots each on DU or DD simultaneously. For monitoring on DU and/or DD the channel registers with even numbers (CDA10, CDA20) are assigned to timeslots with even numbers TS(2n) and the channel registers with odd numbers (CDA11, CDA21) are assigned to timeslots with odd numbers TS(2n+1). The user has to take care of this restriction by programming the appropriate timeslots..

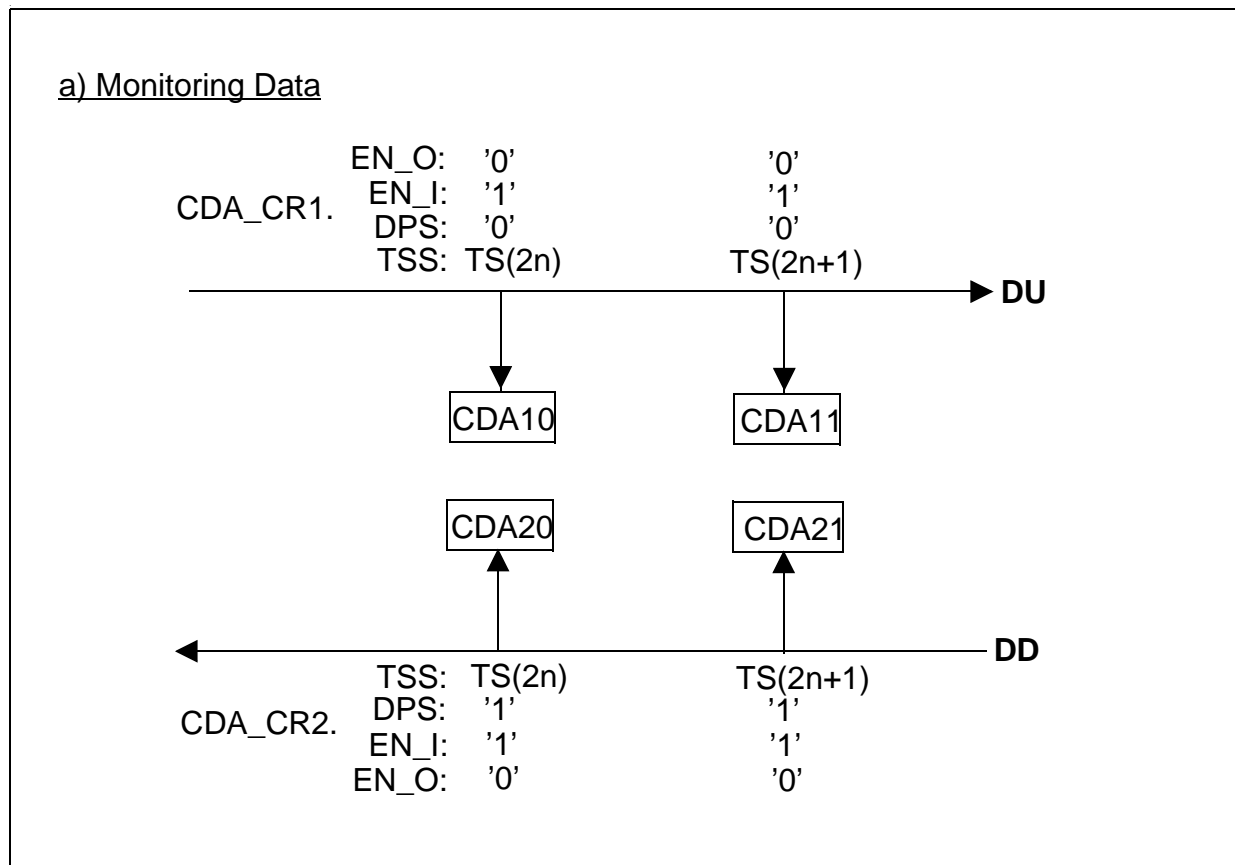

Figure 42 Example for Monitoring Data

Monitoring TIC Bus

Monitoring the TIC bus (TS11) is handled as a special case. The TIC bus can be monitored with the registers CDAx0 by setting the EN_TBM (Enable TIC Bus Monitoring) bit in the control registers CRx. In this special case the TSDPx0 must be set to 08_h for monitoring from DU or 88_h for monitoring from DD respectively. By this it is possible to monitor the TIC bus (TS11) and the odd numbered D-channel (TS3) simultaneously on DU and DD.

Synchronous Transfer

While looping, shifting and switching the data can be accessed by the controller between the synchronous transfer interrupt (STI) and the status overflow interrupt (STOV).

The microcontroller access to the CDA_{xy} registers can be synchronized by means of four programmable synchronous transfer interrupts (STI_{xy})¹⁾ and synchronous transfer overflow interrupts (STOV_{xy})²⁾ in the STI register.

Depending on the DPS bit in the corresponding CDA_TSDP_{xy} register the STI_{xy} is generated two (for DPS='0') or one (for DPS='1') BCL clock after the selected timeslot (CDA_TSDP_{xy}.TSS). One BCL clock is equivalent to two DCL clocks.

In the following description the index xy_0 and xy_1 are used to refer to two different interrupt pairs (STI/STOV) out of the four CDA interrupt pairs (STI10/STOV10, STI11/STOV11, STI20/STOV20, STI21/STOV21).

An STOV_{xy₀} is related to its STI_{xy₀} and is only generated if STI_{xy₀} is enabled and not acknowledged. However, if STI_{xy₀} is masked, the STOV_{xy₀} is generated for any other STI_{xy₁} which is enabled and not acknowledged.

Table 10 gives some examples for that. It is assumed that an STOV interrupt is only generated because an STI interrupt was not acknowledged before.

In example 1 only the STI_{xy₀} is enabled and thus STI_{xy₀} is only generated. If no STI is enabled, no interrupt will be generated even if STOV is enabled (example 2).

In example 3 STI_{xy₀} is enabled and generated and the corresponding STOV_{xy₀} is disabled. STI_{xy₁} is disabled but its STOV_{xy₁} is enabled, and therefore STOV_{xy₁} is generated due to STI_{xy₀}. In example 4 additionally the corresponding STOV_{xy₀} is enabled, so STOV_{xy₀} and STOV_{xy₁} are both generated due to STI_{xy₀}.

In example 5 additionally the STI_{xy₁} is enabled with the result that STOV_{xy₀} is only generated due to STI_{xy₀} and STOV_{xy₁} is only generated due to STI_{xy₁}.

Compared to the previous example STOV_{xy₀} is disabled in example 6, so STOV_{xy₀} is not generated and STOV_{xy₁} is only generated for STI_{xy₁} but not for STI_{xy₀}.

Compared to example 5 in example 7 a third STOV_{xy₂} is enabled and thus STOV_{xy₂} is generated additionally for both STI_{xy₀} and STI_{xy₁}.

¹⁾ In order to enable the STI interrupts the input of the corresponding CDA register has to be enabled. This is also valid if only a synchronous write access is wanted. The enabling of the output alone does not effect an STI interrupt.

²⁾ In order to enable the STOV interrupts the output of the corresponding CDA register has to be enabled. This is also valid if only a synchronous read access is wanted. The enabling of the input alone does not effect an interrupt.

Description of Functional Blocks

Table 10 Examples for Synchronous Transfer Interrupts

Enabled Interrupts (Register MSTI)		Generated Interrupts (Register STI)		
STI	STOV	STI	STOV	
xy ₀	-	xy ₀	-	Example 1
-	xy ₀	-	-	Example 2
xy ₀	xy ₁	xy ₀	xy ₁	Example 3
xy ₀	xy ₀ ; xy ₁	xy ₀	xy ₀ ; xy ₁	Example 4
xy ₀ ; xy ₁	xy ₀ ; xy ₁	xy ₀ xy ₁	xy ₀ xy ₁	Example 5
xy ₀ ; xy ₁	xy ₁	xy ₀ xy ₁	- xy ₁	Example 6
xy ₀ ; xy ₁	xy ₀ ; xy ₁ ; xy ₂	xy ₀ xy ₁	xy ₀ ; xy ₂ xy ₁ ; xy ₂	Example 7

An STOV interrupt is not generated if all stimulating STI interrupts are acknowledged.

An STI_{xy} must be acknowledged by setting the ACK_{xy} bit in the ASTI register until two BCL clocks (for DPS='0') or one BCL clocks (for DPS='1') before the timeslot which is selected for the appropriate STI_{xy}.

The interrupt structure of the synchronous transfer is shown in **Figure 43**.

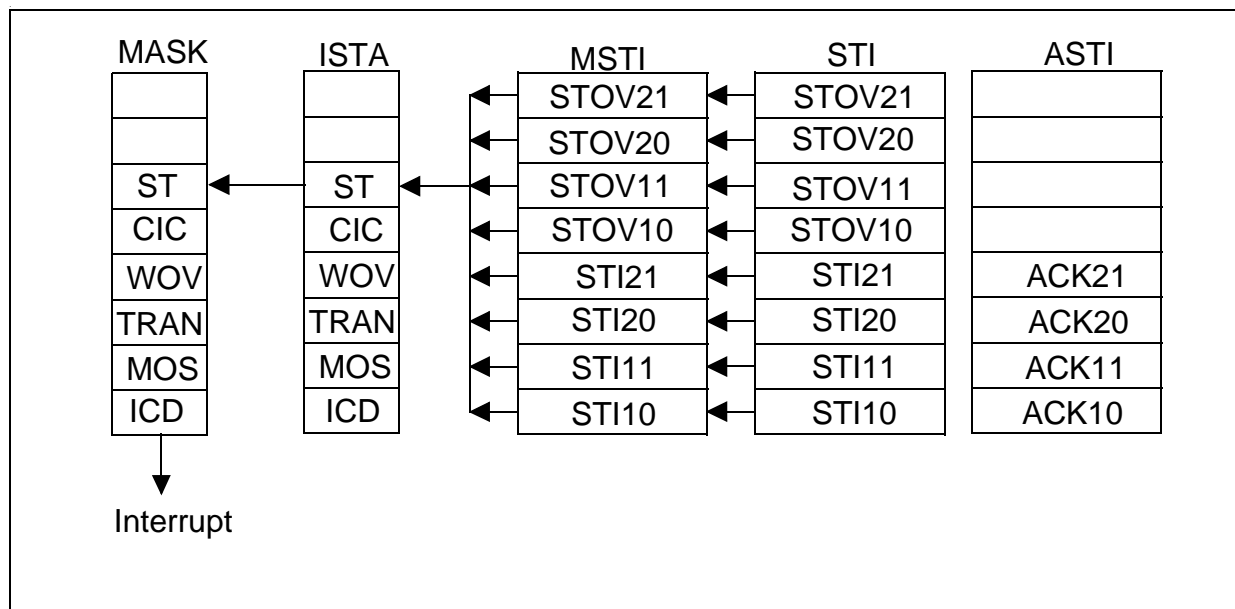

Figure 43 Interrupt Structure of the Synchronous Data Transfer

Description of Functional Blocks

Figure 44 shows some examples based on the timeslot structure. Figure a) shows at which point in time an STI and STOV interrupt is generated for a specific timeslot. Figure b) is identical to example 3 above, figure c) corresponds to example 5 and figure d) shows example 4.

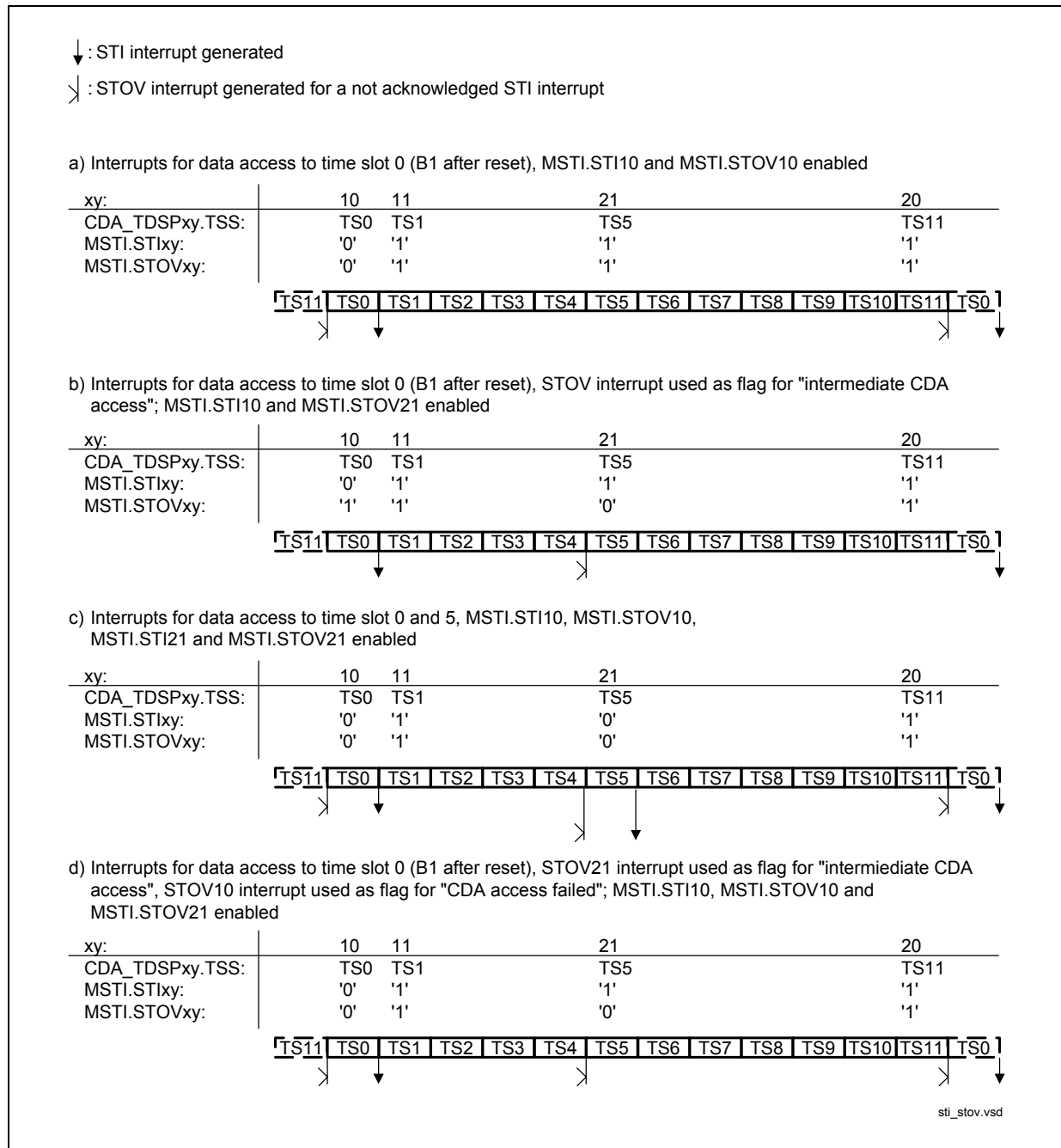

Figure 44 Examples for the Synchronous Transfer Interrupt Control with one Enabled STIxy

Description of Functional Blocks

Restrictions Concerning Monitoring and Shifting Data

Due to the hardware design, there are some restrictions for the CDA shifting data function and for the CDA monitoring data function. The selection of the CDA registers is restricted if other functional blocks of the ISAC-SX TE (transceiver cores, HDLC controllers, CI handler, Monitor handler, TIC bus etc.) access the corresponding timeslot.

If no functional block is assigned to a certain timeslot, any CDA register can be used for monitoring or shifting it.

If a timeslot is already occupied by a functional block in a certain transmission direction, only CDA registers with odd numbers (CDA11/21) can be assigned to odd timeslots and CDA registers with even numbers (CDA10/20) can be assigned to even timeslots in the same transmission direction. For the other transmission direction every CDA register can be used. (Example: If TS 5 is already occupied in DD direction, only CDA11 and 21 can be used for monitoring it. For monitoring TS 5 in DU direction, also CDA10 or CDA20 could be used.)

If above guideline is not considered, data can be overwritten in corresponding timeslots. In this context no general rules can be derived in which way the data are overwritten.

The usage of the looping data and switching data functions are unrestricted.

Restrictions Concerning Read/Write Access

If data shall be read out from a certain transmission direction and other data shall be written in the opposite transmission direction in the same timeslot, only special CDA register combinations can be used. The correct behavior can be achieved with the following CDA register combinations:

Table 11 CDA Register Combinations with Correct Read/Write Access

CDA Register Combination	1	2	3	4
Data of the downstream timeslot is read by	CDA10	CDA11	CDA20	CDA21
Data is written to the upstream timeslot from	CDA20	CDA21	CDA10	CDA11

With other register combinations unintended loops or erroneous monitorings can occur or wrong data is written to the IOM interface.

Unexpected Write/Read Behavior of CDA Registers

If inputs and outputs are disabled, the programmed values of CDA10/11/20/21 registers cannot be read back. Instead of the expected value the content of the previous programming can be read out. The programmed value (5A_H in the following example) will be fetched if the output is enabled.

Example:

w CDA1_CR = 00_H (inputs and outputs are disabled)
w CDA10 = 5A_H (example)
r CDA10 = FF_H (old value of previous programming)
w CDA1_CR = 02_H (output of CDA10 is enabled)
r CDA10 = 5A_H (the programmed value can be read back)

3.7.2 Serial Data Strobe Signal and Strobed Data Clock

For timeslot oriented standard devices connected to the IOM-2 interface the ISAC-SX TE provides an independent data strobe signal SDS. Instead of a data strobe signal a strobed IOM-2 bit clock can be provided on pin SDS.

3.7.2.1 Serial Data Strobe Signal

The strobe signal can be generated with every 8-kHz frame and is controlled by the register SDS_CR. By programming the TSS bits and three enable bits (ENS_TSS, ENS_TSS+1, ENS_TSS+3) a data strobe can be generated for the IOM-2 timeslots TS, TS+1 and TS+3 and any combination of them.

The data strobe for TS and TS+1 are always 8 bits long (bit7 to bit0) whereas the data strobe for TS+3 is always 2 bits long (bit7, bit6).

Figure 45 shows three examples for the generation of a strobe signal. In example 1 the SDS is active during channel B2 on IOM-2 whereas in the second example during IC2 and MON1. The third example shows a strobe signal for 2B+D channels which can be used e.g. for an IDSL (144kbit/s) transmission.

Description of Functional Blocks

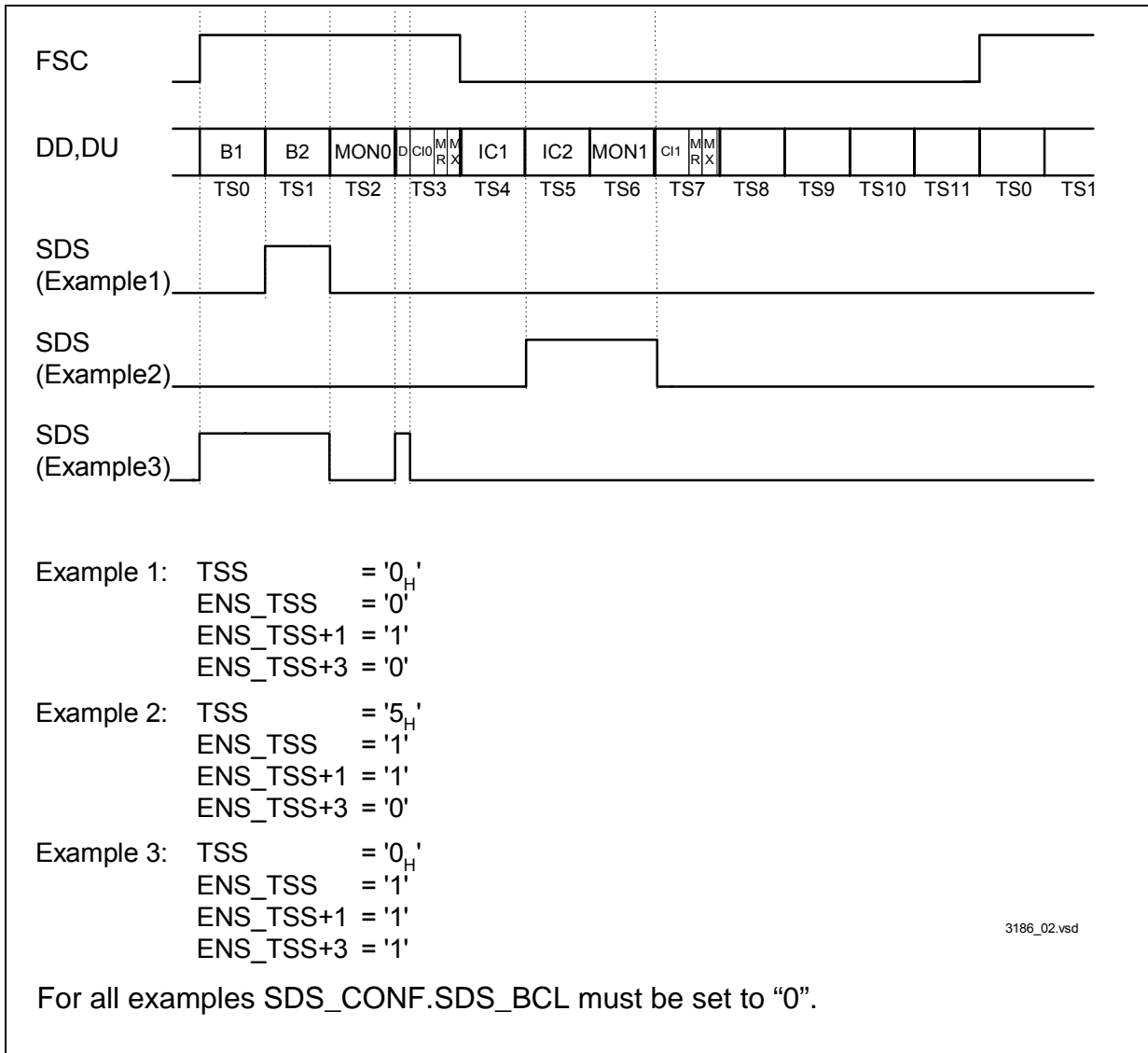

3186_02.vsd

Figure 45 Data Strobe Signal

3.7.2.2 Strobed IOM-2 Bit Clock

The strobed IOM-2 bit clock is active during the programmed window. Outside the programmed window a '0' is driven. Two examples are shown in [Figure 46](#).

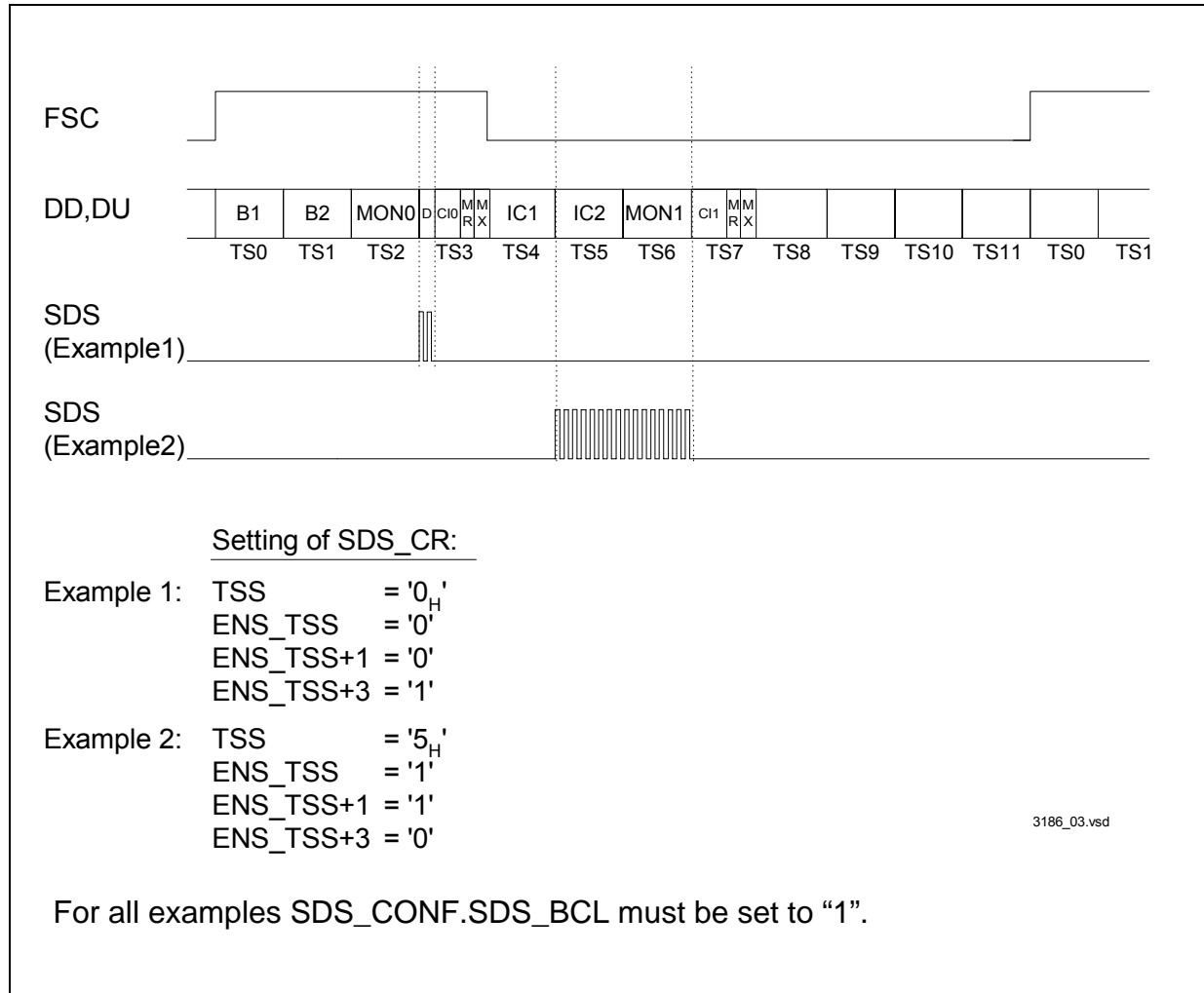

Figure 46 Strobed IOM-2 Bit Clock. Register SDS_CONF programmed to 01_H

The strobed bit clock can be enabled in SDS_CONF.SDS_BCL.

3.7.3 IOM-2 Monitor Channel

The IOM-2 MONITOR channel ([Figure 47](#)) is utilized for information exchange in the MONITOR channel between a master mode device and a slave mode device.

The MONITOR channel data can be controlled by the bits in the MONITOR control register (MON_CR). For the transmission of the MONITOR data one of the IOM-2 channels (3 IOM-2 channels in TE mode) can be selected by setting the MONITOR channel selection bits (MCS) in the MONITOR control register (MON_CR).

Description of Functional Blocks

The DPS bit in the same register selects between an output on DU or DD respectively and with EN_MON the MONITOR data can be enabled/disabled. The default value is MONITOR channel 0 (MON0) enabled and transmission on DD.

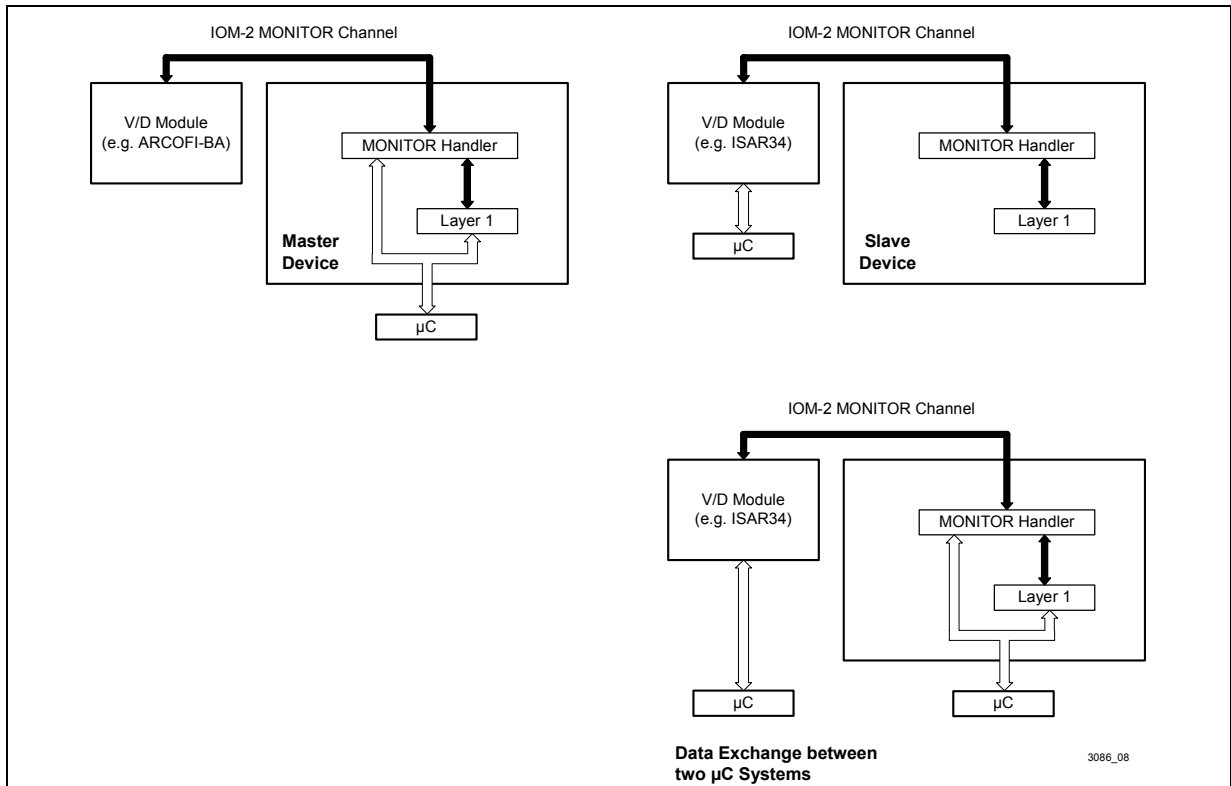

Figure 47 Examples of MONITOR Channel Applications in IOM -2 TE Mode

The MONITOR channel of the ISAC-SX TE can be used in following applications which are illustrated in **Figure 47**:

- As a **master device** the ISAC-SX TE can program and control other devices attached to the IOM-2 which do not need a parallel microcontroller interface e.g. ARCOFI-BA PSB 2161. This facilitates redesigning existing terminal designs in which e.g. an interface of an expansion slot is realized with IOM-2 interface and monitor programming.
- As a **slave device** the transceiver part of the ISAC-SX TE is programmed and controlled from a master device on IOM-2 (e.g. ISAR34 PSB 7115). This is used in applications where no microcontroller is connected directly to the ISAC-SX TE in order to simplify host interface connection. The HDLC controlling is processed by the master device therefore the HDLC data is transferred via IOM-2 interface directly to the master device.
- For **data exchange** between two microcontroller systems attached to two different devices on one IOM-2 backplane. Use of the MONITOR channel avoids the necessity of a dedicated serial communication path between the two systems. This simplifies the system design of terminal equipment.

3.7.3.1 Handshake Procedure

The MONITOR channel operates on an asynchronous basis. While data transfers on the bus take place synchronized to frame sync, the flow of data is controlled by a handshake procedure using the MONITOR Channel Receive (MR) and MONITOR Channel Transmit (MX) bits. Data is placed onto the MONITOR channel and the MX bit is activated. This data will be transmitted once per 8-kHz frame until the transfer is acknowledged via the MR bit.

The MONITOR channel protocol is described in the following section and [Figure 48](#) illustrates this. The relevant control and status bits for transmission and reception are listed in [Table 12](#) and [Table 13](#).

Table 12 Transmit Direction

Control/ Status Bit	Register	Bit	Function
Control	MOCR	MXC	MX Bit Control
		MIE	Transmit Interrupt Enable
Status	MOSR	MDA	Data Acknowledged
		MAB	Data Abort
	MSTA	MAC	Transmission Active

Table 13 Receive Direction

Control/ Status Bit	Register	Bit	Function
Control	MOCR	MRC	MR Bit Control
		MRE	Receive Interrupt Enable
Status	MOSR	MDR	Data Received
		MER	End of Reception

Description of Functional Blocks

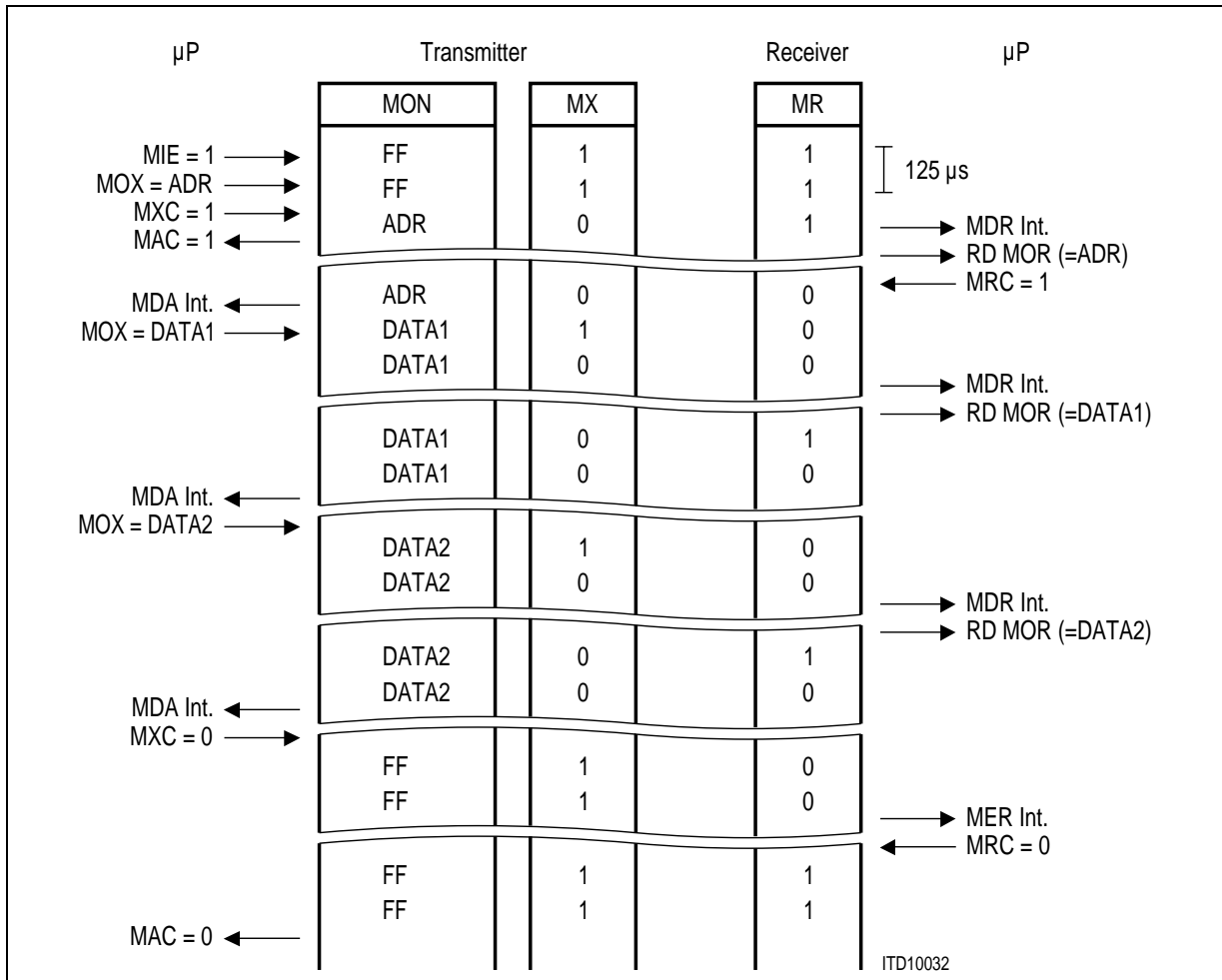

Figure 48 MONITOR Channel Protocol (IOM-2)

Before starting a transmission, the microprocessor should verify that the transmitter is inactive, i.e. that a possible previous transmission has been terminated. This is indicated by a '0' in the MONITOR Channel Active MAC status bit.

After having written the MONITOR Data Transmit (MOX) register, the microprocessor sets the MONITOR Transmit Control bit MXC to '1'. This enables the MX bit to go active (0), indicating the presence of valid MONITOR data (contents of MOX) in the corresponding frame. As a result, the receiving device stores the MONITOR byte in its MONITOR Receive MOR register and generates an MDR interrupt status.

Alerted by the MDR interrupt, the microprocessor reads the MONITOR Receive (MOR) register. When it is ready to accept data (e.g. based on the value in MOR, which in a point-to-multipoint application might be the address of the destination device), it sets the MR control bit MRC to '1' to enable the receiver to store succeeding MONITOR channel bytes and acknowledge them according to the MONITOR channel protocol. In addition, it enables other MONITOR channel interrupts by setting MONITOR Interrupt Enable (MIE) to '1'.

Description of Functional Blocks

As a result, the first MONITOR byte is acknowledged by the receiving device setting the MR bit to '0'. This causes a MONITOR Data Acknowledge MDA interrupt status at the transmitter.

A new MONITOR data byte can now be written by the microprocessor in MOX. The MX bit is still in the active (0) state. The transmitter indicates a new byte in the MONITOR channel by returning the MX bit active after sending it once in the inactive state. As a result, the receiver stores the MONITOR byte in MOR and generates a new MDR interrupt status. When the microprocessor has read the MOR register, the receiver acknowledges the data by returning the MR bit active after sending it once in the inactive state. This in turn causes the transmitter to generate an MDA interrupt status.

This "MDA interrupt – write data – MDR interrupt – read data – MDA interrupt" handshake is repeated as long as the transmitter has data to send. Note that the MONITOR channel protocol imposes no maximum reaction times to the microprocessor.

When the last byte has been acknowledged by the receiver (MDA interrupt status), the microprocessor sets the MONITOR Transmit Control bit MXC to '0'. This enforces an inactive ('1') state in the MX bit. Two frames of MX inactive signifies the end of a message. Thus, a MONITOR Channel End of Reception MER interrupt status is generated by the receiver when the MX bit is received in the inactive state in two consecutive frames. As a result, the microprocessor sets the MR control bit MRC to 0, which in turn enforces an inactive state in the MR bit. This marks the end of the transmission, making the MONITOR Channel Active MAC bit return to '0'.

During a transmission process, it is possible for the receiver to ask a transmission to be aborted by sending an inactive MR bit value in two consecutive frames. This is effected by the microprocessor writing the MR control bit MRC to '0'. An aborted transmission is indicated by a MONITOR Channel Data Abort MAB interrupt status at the transmitter.

The MONITOR transfer protocol rules are summarized in the following section:

- A pair of MX and MR in the inactive state for two or more consecutive frames indicates an **idle state** or an **end of transmission**.
- A **start of a transmission** is initiated by the transmitter by setting the MXC bit to '1' enabling the internal MX control. The receiver acknowledges the received first byte by setting the MR control bit to '1' enabling the internal MR control.
- The internal MX,MR control indicates or acknowledges a new byte in the MON slot by toggling MX,MR from the active to the inactive state for one frame.
- Two frames with the MX-bit in the inactive state indicate the **end of transmission**.
- Two frames with the MR-bit set to inactive indicate a receiver request for **abort**.
- The transmitter can **delay a transmission** sequence by sending the same byte continuously. In that case the MX-bit remains active in the IOM-2 frame following the first byte occurrence. Delaying a transmission sequence is only possible while the receiver MR-bit and the transmitter MX-bit are active.

Description of Functional Blocks

- Since a **double last-look criterion** is implemented the receiver is able to receive the MON slot data at least twice (in two consecutive frames), the receiver waits for the acknowledge of the reception of two identical bytes in two successive frames.
- To control this handshake procedure a collision detection mechanism is implemented in the transmitter. This is done by making a **collision check** per bit on the transmitted MONITOR data and the MX bit.
- Monitor data will be transmitted repeatedly until its reception is acknowledged or the transmission time-out timer expires.
- Two frames with the MX bit in the inactive state indicates the **end of a message** (EOM).
- Transmission and reception of monitor messages can be performed simultaneously. This feature is used by the ISAC-SX TE to send back the response before the transmission from the controller is completed (the ISAC-SX TE does not wait for EOM from controller).

3.7.3.2 Error Treatment

In case the ISAC-SX TE does not detect identical monitor messages in two successive frames, transmission is not aborted. Instead the ISAC-SX TE will wait until two identical bytes are received in succession.

A transmission is aborted of the ISAC-SX TE if

- an error in the MR handshaking occurs
- a collision on the IOM-2 bus of the MONITOR data or MX bit occurs
- the transmission time-out timer expires

A reception is aborted by the device if

- an error in the MX handshaking occurs or
- an abort request from the opposite device occurs

MX/MR Treatment in Error Case

In the master mode the MX/MR bits are under control of the microcontroller through MXC or MRC, respectively. An abort is indicated by an MAB interrupt or MER interrupt, respectively.

In the slave mode the MX/MR bits are under control of the device. An abort is always indicated by setting the MX/MR bit inactive for two or more IOM-2 frames. The controller must react with EOM.

Figure 49 shows an example for an abort requested by the receiver, **Figure 50** shows an example for an abort requested by the transmitter and **Figure 51** shows an example for a successful transmission.

Description of Functional Blocks

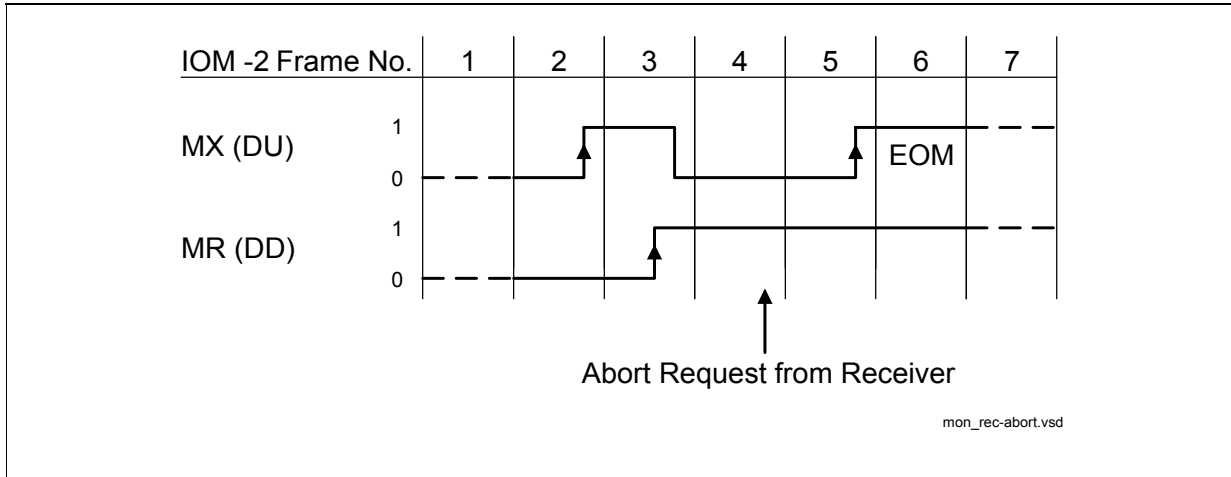

Figure 49 Monitor Channel, Transmission Abort requested by the Receiver

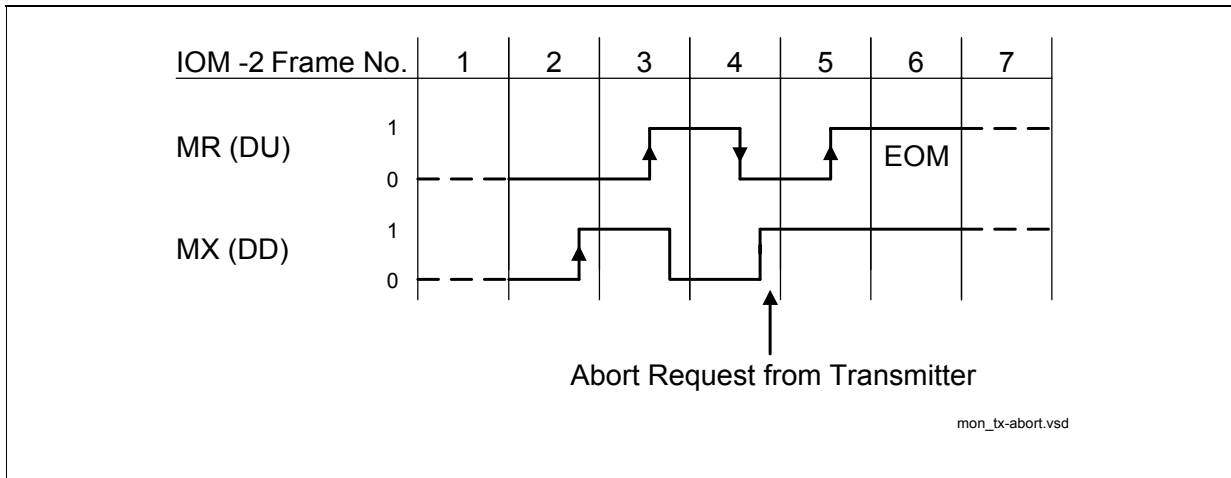

Figure 50 Monitor Channel, Transmission Abort requested by the Transmitter

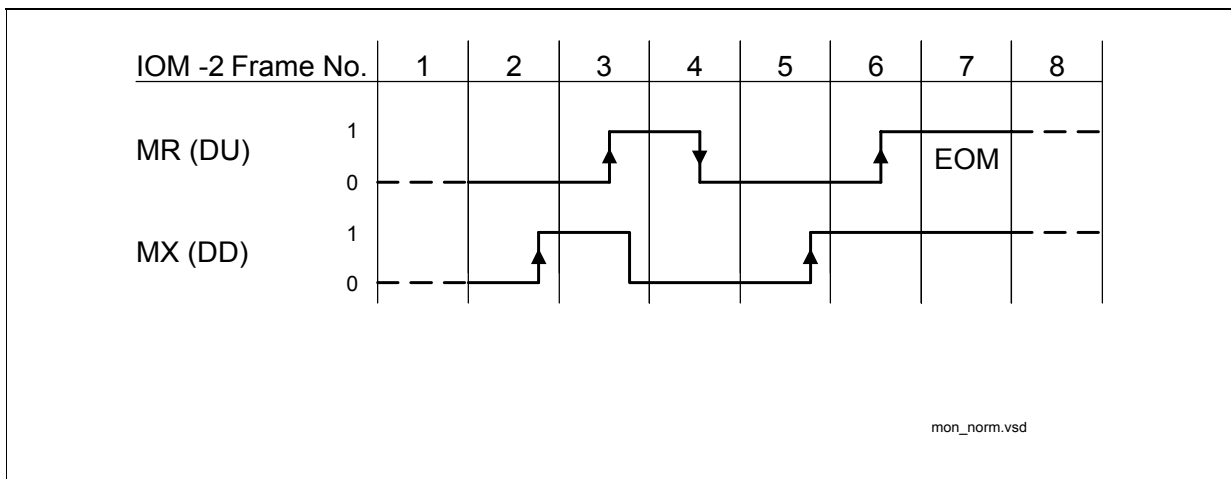

Figure 51 Monitor Channel, Normal End of Transmission

3.7.3.3 MONITOR Channel Programming as a Master Device

As a master device the ISAC-SX TE can program and control other devices attached to the IOM-2 interface. The master mode is selected by default if one of the possible microcontroller interfaces are selected. The monitor data is written by the microprocessor in the MOX register and transmitted via IOM-2 DD (DU) line to the programmed/controlled device e.g. ARCOFI-BA PSB 2161 or IEC-Q TE PSB 21911. The transfer of the commands in the MON channel is regulated by the handshake protocol mechanism with MX, MR which is described in the previous chapter [Chapter 3.7.3.1](#).

If the transmitted command was a read command the slave device responds by sending the requested data.

The data structure of the transmitted monitor message depends on the device which is programmed. Therefore the first byte of the message is a specific address code which contains in the higher nibble a MONITOR channel address to identify different devices. The length of the messages depends on the accessed device and the type of MONITOR command.

3.7.3.4 MONITOR Channel Programming as a Slave Device

In applications without direct host controller connection the ISAC-SX TE must operate in the MONITOR slave mode which can be selected by pinstrapping the microcontroller interface pins according [Table 3](#) respectively in [Chapter 3.2](#). As a slave device the transceiver part of the ISAC-SX TE is programmed and controlled by a master device at the IOM-2 interface. All programming data required by the ISAC-SX TE is received in the MONITOR timeslot on the IOM-2 and is transferred in the MOR register. The transfer of the commands in the MON channel is regulated by the handshake protocol mechanism with MX, MR which is described in the previous [Chapter 3.7.3.1](#).

The first byte of the MONITOR message must contain in the higher nibble the MONITOR channel address code which is '1010' for the ISAC-SX TE. The lower nibble distinguishes between a programming command or an identification command.

Identification Command

In order to be able to identify unambiguously different hardware designs of the ISAC-SX TE by software, the following identification command is used:

DD 1st byte value	1	0	1	0	0	0	0	0
DD 2nd byte value	0	0	0	0	0	0	0	0

The ISAC-SX TE responds to this DD identification sequence by sending a DU identification sequence:

DESIGN:six bit code, specific for each device in order to identify differences in operation

Description of Functional Blocks

DU 1st byte value	1	0	1	0	0	0	0	0
DU 2nd byte value	0	1	DESIGN				<IDENT>	

e.g. 000001 ISAC-SX TE PSB 3186 V 1.4

This identification sequence is usually done once, when the terminal is connected for the first time. This function is used so that the software can distinguish between different possible hardware configurations. However this sequence is not compulsory.

Programming Sequence

The programming sequence is characterized by a '1' being sent in the lower nibble of the received address code. The data structure after this first byte and the principle of a read/write access to a register is similar to the structure of the serial control interface described in [Chapter 3.2.1.1](#). For write access the header 43_H/47_H can be used and for read access the header 40_H/44_H.

DD 1st byte value	1	0	1	0	0	0	0	1
DD 2nd byte value	Header Byte							
DD 3rd byte value	R/W	Register Address						
DD 4th byte value	Data 1							
DD (nth + 3) byte value	Data n							

All registers can be read back when setting the R/W bit in the byte for the command/register address. The ISAC-SX TE responds by sending its IOM-2 specific address byte (A1_H) followed by the requested data.

Note: Application Hint:

It is not allowed to disable the MX- and MR-control in the programming device at the same time! First, the MX-control must be disabled, then the μ C has to wait for an End of Reception before the MR-control may be disabled. Otherwise, the ISAC-SX TE does not recognize an End of Reception.

3.7.3.5 Monitor Time-Out Procedure

To prevent lock-up situations in a MONITOR transmission a time-out procedure can be enabled by setting the time-out bit (TOUT) in the MONITOR configuration register (MCONF). An internal timer is always started when the transmitter must wait for the reply of the addressed device. After 5 ms without reply the timer expires and the transmission will be aborted with a EOM (End of Message) command by setting the MX bit to '1' for two consecutive IOM-2 frames.

3.7.3.6 MONITOR Interrupt Logic

Figure 52 shows the MONITOR interrupt structure of the ISAC-SX TE. The MONITOR Data Receive interrupt status **MDR** has two enable bits, MONITOR Receive interrupt Enable (**MRE**) and MR bit Control (**MRC**). The MONITOR channel End of Reception **MER**, MONITOR channel Data Acknowledged **MDA** and MONITOR channel Data Abort **MAB** interrupt status bits have a common enable bit MONITOR Interrupt Enable **MIE**.

MRE prevents the occurrence of **MDR** status, including when the first byte of a packet is received. When **MRE** is active (1) but **MRC** is inactive, the **MDR** interrupt status is generated only for the first byte of a receive packet. When both **MRE** and **MRC** are active, **MDR** is always generated and all received MONITOR bytes - marked by a 1-to-0 transition in MX bit - are stored. (Additionally, an active **MRC** enables the control of the MR handshake bit according to the MONITOR channel protocol.)

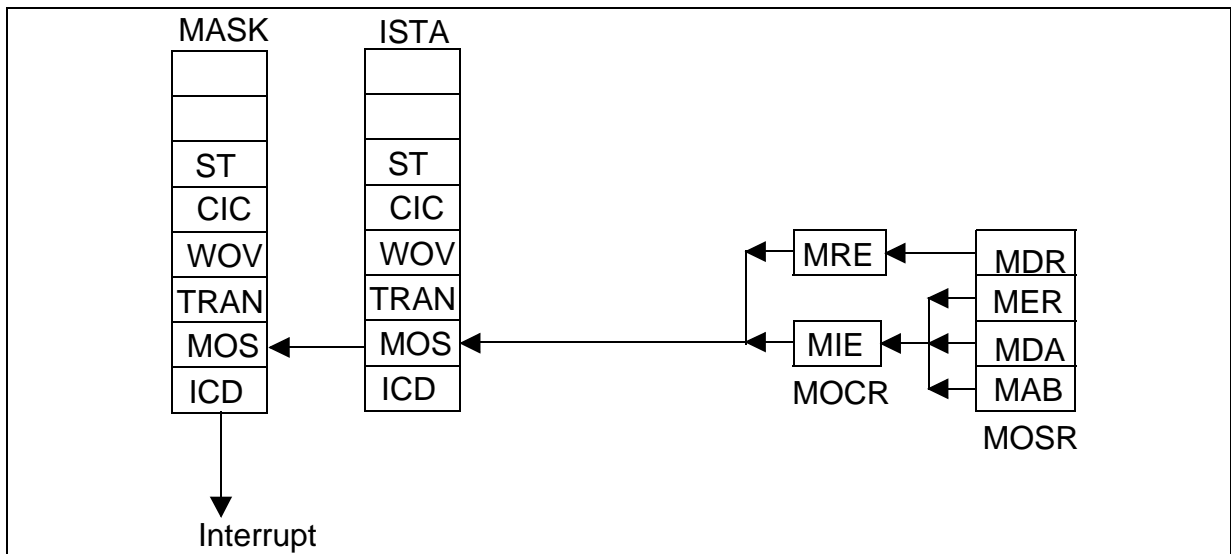

Figure 52 MONITOR Interrupt Structure

3.7.4 C/I Channel Handling

The Command/Indication channel carries real-time status information between the ISAC-SX TE and another device connected to the IOM-2 interface.

1) One C/I channel (called C/I0) conveys the commands and indications between the layer-1 and the layer-2 parts of the ISAC-SX TE. It can be accessed by an external layer-2 device e.g. to control the layer-1 activation/deactivation procedures. C/I0 channel access may be arbitrated via the TIC bus access protocol. In this case the arbitration is done in IOM-2 channel 2 (see **Figure 36**).

The C/I0 channel is accessed via register CIR0 (in receive direction, layer-1 to layer-2) and register CIX0 (in transmit direction, layer-2 to layer-1). The C/I0 code is four bits long. A listing and explanation of the layer-1 C/I codes can be found in **Chapter 3.5.2**.

In the receive direction, the code from layer-1 is continuously monitored, with an interrupt

Description of Functional Blocks

being generated anytime a change occurs (ISTA.CIC). A new code must be found in two consecutive IOM-2 frames to be considered valid and to trigger a C/I code change interrupt status (double last look criterion).

In the transmit direction, the code written in CIX0 is continuously transmitted in C/I0.

2) A second C/I channel (called C/I1) can be used to convey real time status information between the ISAC-SX TE and various non-layer-1 peripheral devices e.g. PSB 2161 ARCOFI-BA. The C/I1 channel consists of four or six bits in each direction. The width can be changed from 4bit to 6bit by setting bit CIX1.CICW.

In 4-bit mode 6-bits are written whereby the higher 2 bits must be set to "1" and 6-bits are read whereby only the 4 LSBs are used for comparison and interrupt generation (i.e. the higher two bits are ignored).

The C/I1 channel is accessed via registers CIR1 and CIX1. A change in the received C/I1 code is indicated by an interrupt status without double last look criterion.

CIC Interrupt Logic

Figure 53 shows the CIC interrupt structure.

A CIC interrupt may originate

- from a change in received C/I channel 0 code (CIC0)

or

- from a change in received C/I channel 1 code (CIC 1).

The two corresponding status bits CIC0 and CIC1 are read in CIR0 register. CIC1 can be individually disabled by clearing the enable bit CI1E in the CIX1 register. In this case the occurrence of a code change in CIR1 will not be displayed by CIC1 until the corresponding enable bit has been set to one.

Bits CIC0 and CIC1 are cleared by a read of CIR0.

An interrupt status is indicated every time a valid new code is loaded in CIR0 or CIR1. The CIR0 is buffered with a FIFO size of two. If a second code change occurs in the received C/I channel 0 before the first one has been read, immediately after reading of CIR0 a new interrupt will be generated and the new code will be stored in CIR0. If several consecutive codes are detected, only the first and the last code is obtained at the first and second register read, respectively.

For CIR1 no FIFO is available. The actual code of the received C/I channel 1 is always stored in CIR1.

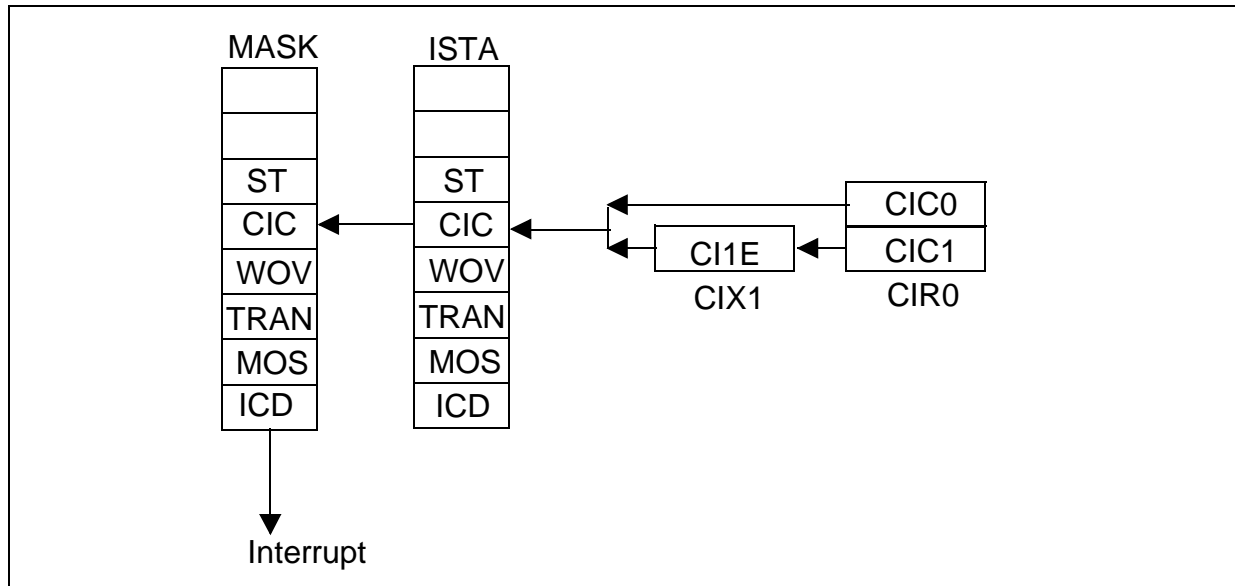

Figure 53 CIC Interrupt Structure

3.7.5 D-Channel Access Control

D-channel access control is defined to guarantee all connected TEs and HDLC controllers a fair chance to transmit data in the D-channel. Collisions are possible

- on the IOM-2 interface if there is more than one HDLC controller connected or
- on the S-interface when there is more than one terminal connected in a point to multipoint configuration (NT → TE1 ... TE8).

Both arbitration mechanisms are implemented in the ISAC-SX TE and will be described in the following two chapters.

3.7.5.1 TIC Bus D-Channel Access Control

The TIC bus is implemented to organize the access to the layer-1 functions provided in the ISAC-SX TE (C/I-channel) and to the D-channel from up to 7 external communication controllers (Figure 54).

Note: *If the TIC Bus feature is not used, it has to be switched off in order not to disturb the layer-1 control and the HDLC controller. This is done by setting bit DIM 1 in register Mode D and bit 4 in register IOM_CR. For more details please refer to the application note “Reconfigurable PBX”.*

To this effect the outputs of the D-channel controllers (e.g. ICC - ISDN Communication Controller PEB 2070) are wired-or (negative logic, i.e. a “0” wins) and connected to pin DU. The inputs of the ICCs are connected to pin DD. External pull-up resistors on DU/DD are required. The arbitration mechanism must be activated by setting MODED.DIM2-0=00x.

Description of Functional Blocks

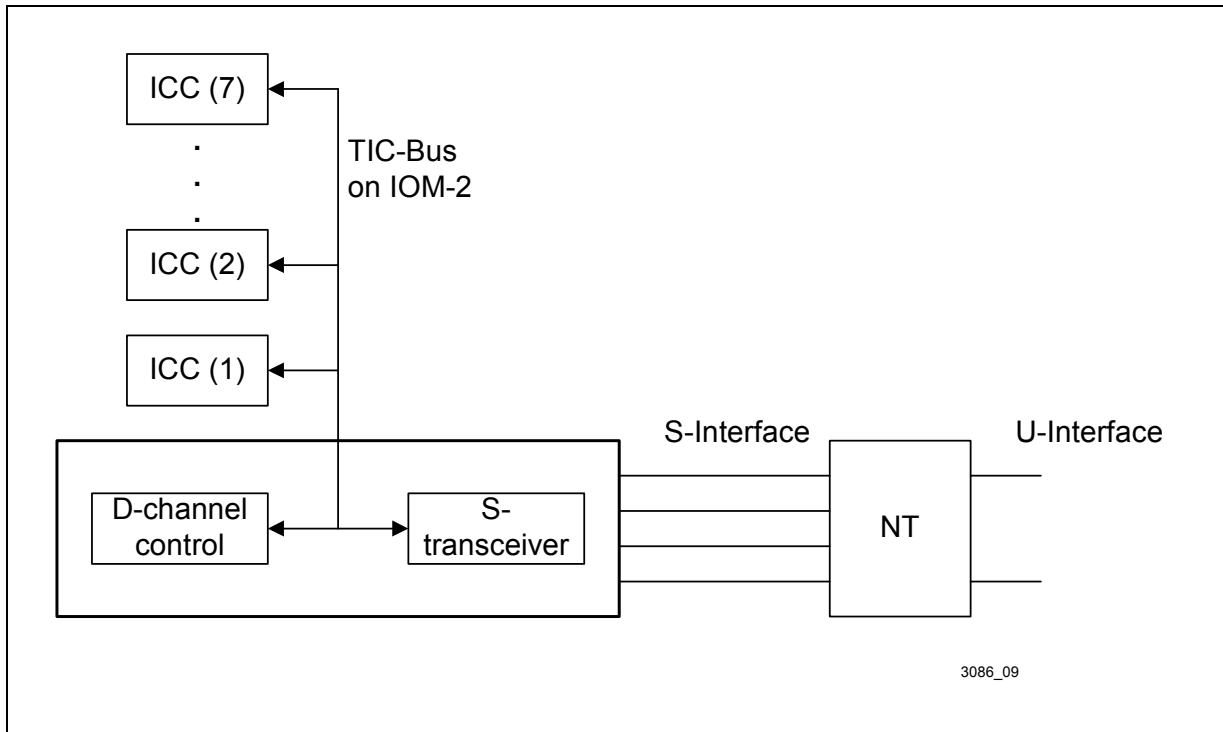

Figure 54 Applications of TIC Bus in IOM-2 Bus Configuration

The arbitration mechanism is implemented in the last octet in IOM-2 channel 2 of the IOM-2 interface (Figure 55). An access request to the TIC bus may either be generated by software (μ P access to the C/I channel) or by the ISAC-SX TE itself (transmission of an HDLC frame in the D-channel). A software access request to the bus is effected by setting the BAC bit (CIX0 register) to '1'.

In the case of an access request, the ISAC-SX TE checks the Bus Accessed-bit BAC (bit 5 of last octet of CH2 on DU, Figure 55) for the status "bus free", which is indicated by a logical '1'. If the bus is free, the ISAC-SX TE transmits its individual TIC bus address TAD programmed in the CIX0 register (CIX0.TBA2-0). The ISAC-SX TE sends its TIC bus address TAD and compares it bit by bit with the value on DU. If a sent bit set to '1' is read back as '0' because of the access of another D-channel source with a lower TAD, the ISAC-SX TE withdraws immediately from the TIC bus, i.e. the remaining TAD bits are not transmitted. The TIC bus is occupied by the device which sends its address error-free. If more than one device attempt to seize the bus simultaneously, the one with the lowest address values wins. This one will set BAC=0 on TIC bus and starts D-channel transmission in the same frame.

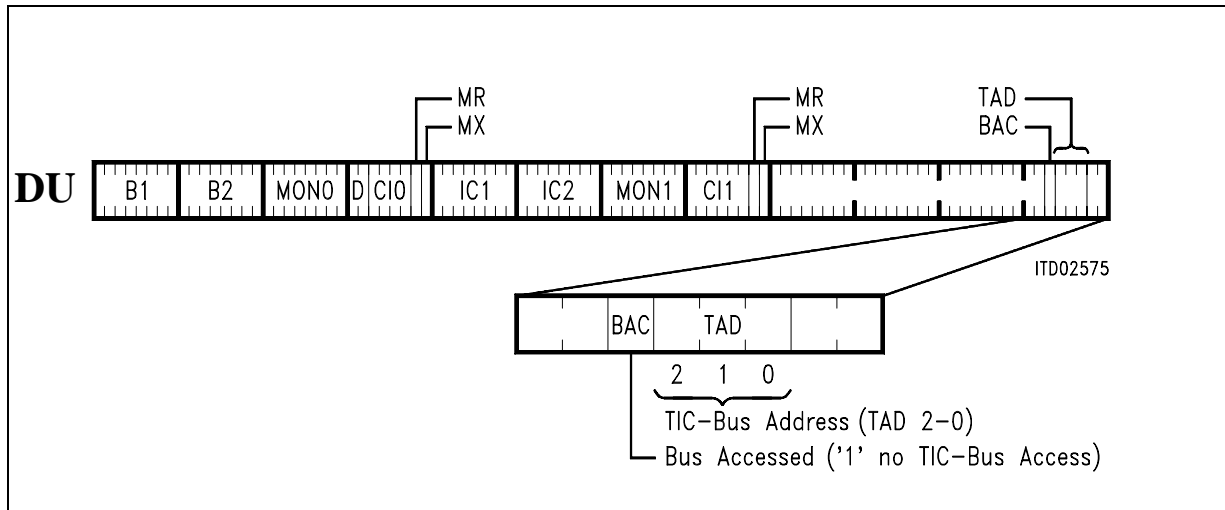

Figure 55 Structure of Last Octet of Ch2 on DU

When the TIC bus is seized by the ISAC-SX TE, the bus is identified to other devices as occupied via the DU Ch2 Bus Accessed-bit state '0' until the access request is withdrawn. After a successful bus access, the ISAC-SX TE is automatically set into a lower priority class, that is, a new bus access cannot be performed until the status "bus free" is indicated in two successive frames.

If none of the devices connected to the IOM-2 interface request access to the D and C/I channels, the TIC bus address 7 will be present. The device with this address will therefore have access, by default, to the D and C/I channels.

Note: Bit BAC (CIX0 register) should be reset by the μP when access to the C/I channels is no more requested, to grant other devices access to the D and C/I channels.

3.7.5.2 S-Bus Priority Mechanism for D-Channel

The S-bus access procedure specified in ITU I.430 was defined to organize D-channel access with multiple TEs connected to a single S-bus (**Figure 57**).

To implement collision detection the D (channel) and E (echo) bits are used. The D-channel S-bus condition is indicated towards the IOM-2 interface with the S/G bit, i.e. the availability of the S/T interface D channel is indicated in bit 5 "Stop/Go" (S/G) of the DD last octet of Ch2 channel (**Figure 56**).

S/G = 1 : stop

S/G = 0 : go

Description of Functional Blocks

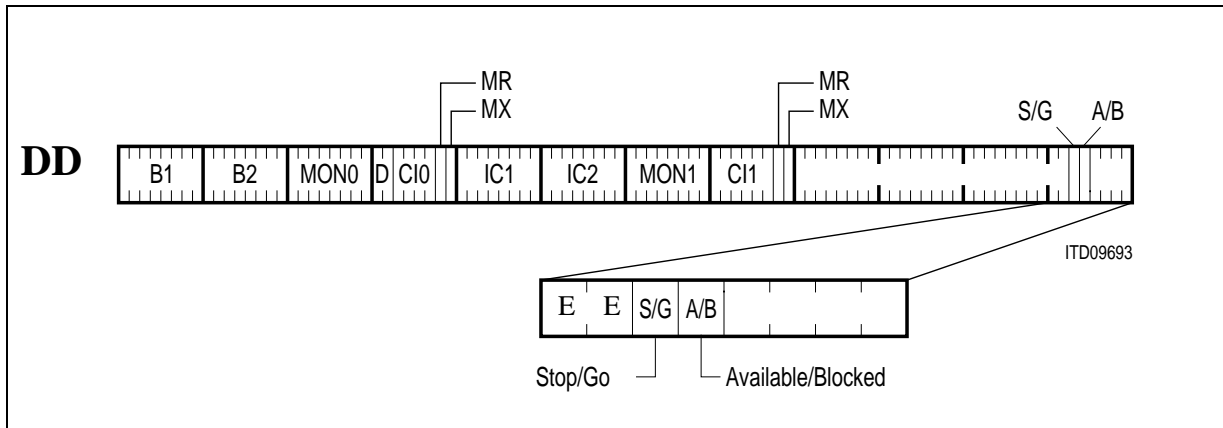

Figure 56 Structure of Last Octet of Ch2 on DD

The Stop/Go bit is available to other layer-2 devices connected to the IOM-2 interface to determine if they can access the S/T bus D channel.

The access to the D-channel is controlled by a priority mechanism which ensures that all competing TEs are given a fair access chance. This priority mechanism discriminates among the kind of information exchanged and information exchange history: Layer-2 frames are transmitted in such a way that signalling information is given priority (priority class 1) over all other types of information exchange (priority class 2). Furthermore, once a TE having successfully completed the transmission of a frame, it is assigned a lower level of priority of that class. The TE is given back its normal level within a priority class when all TEs have had an opportunity to transmit information at the normal level of that priority class.

The priority mechanism is based on a rather simple method: A TE not transmitting layer-2 frames sends binary 1s on the D-channel. As layer-2 frames are delimited by flags consisting of the binary pattern “01111110” and zero bit insertion is used to prevent flag imitation, the D-channel may be considered idle if more than seven consecutive 1s are detected on the D-channel. Hence by monitoring the D echo channel, the TE may determine if the D-channel is currently used by another TE or not.

A TE may start transmission of a layer-2 frame first when a certain number of consecutive 1s has been received on the echo channel. This number is fixed to 8 in priority class 1 and to 10 in priority class 2 for the normal level of priority; for the lower level of priority the number is increased by 1 in each priority class, i.e. 9 for class 1 and 11 for class 2.

A TE, when in the active condition, is monitoring the D echo channel, counting the number of consecutive binary 1s. If a 0 bit is detected, the TE restarts counting the number of consecutive binary 1s. If the required number of 1s according to the actual level of priority has been detected, the TE may start transmission of an HDLC frame. If a collision occurs, the TE immediately shall cease transmission, return to the D-channel monitoring state, and send 1s over the D-channel.

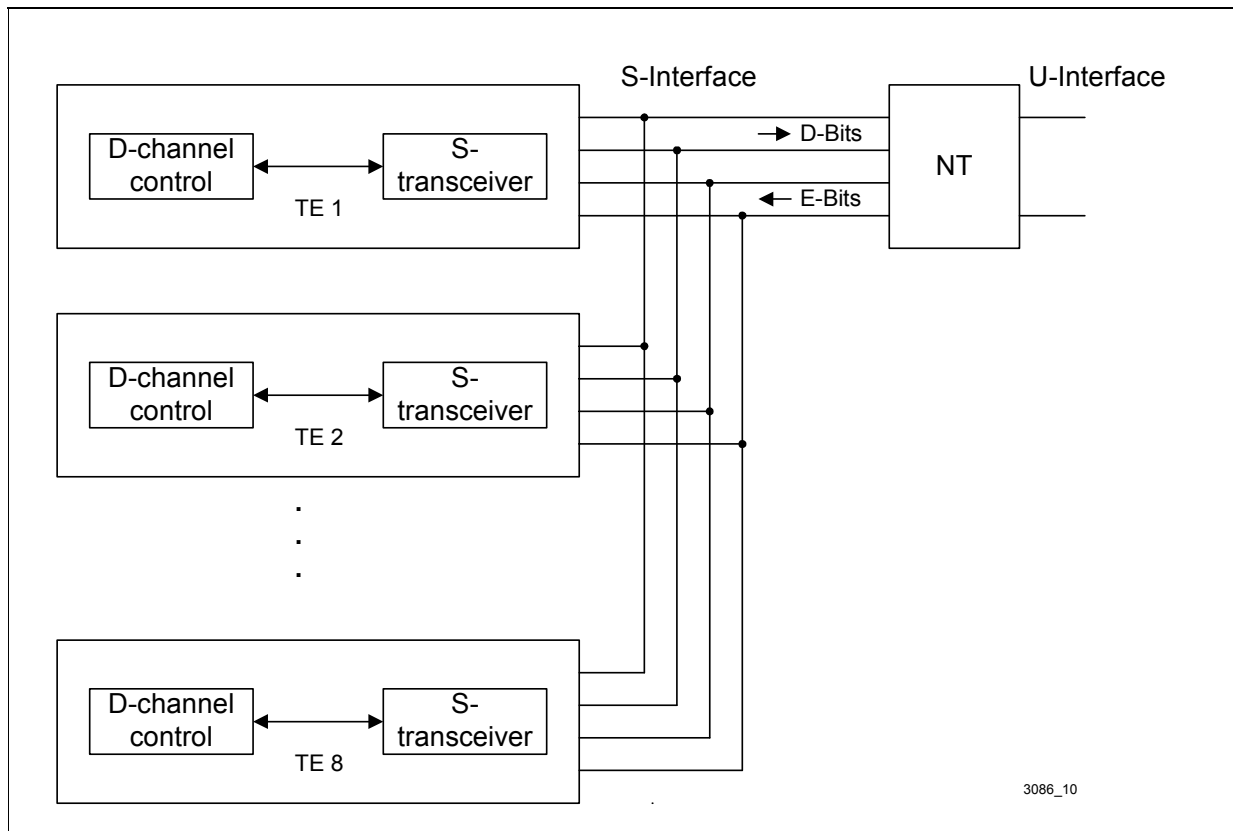

Figure 57 D-Channel Access Control on the S-Interface

S-Bus D-channel Access Control in the ISAC-SX TE

The above described priority mechanism is fully implemented in the ISAC-SX TE. For this purpose the D-channel collision detection according to ITU I.430 must be enabled by setting MODED.DIM2-0 to '0x1'. In this case the transceiver continuously compares the received E-echo bits with its own transmitted D data bits.

Depending on the priority class selected, 8 or 10 consecutive ONEs (high priority level, priority 8) need to be detected before the transceiver sends valid D-channel data on the upstream D-bits on S. In low priority level (priority 10) 10 or 11 consecutive ONEs are required.

The priority class (priority 8 or priority 10) is selected by transferring the appropriate activation command via the Command/Indication (C/I) channel of the IOM-2 interface to the transceiver. If the activation is initiated by a TE, the priority class is selected implicitly by the choice of the activation command. If the S-interface is activated from the NT, an activation command selecting the desired priority class should be programmed at the TE on reception of the activation indication (AI8 or AI10). In the activated state the priority class may be changed whenever required by simply programming the desired activation request command (AR8 or AR10).

3.7.6 Activation/Deactivation of IOM-2 Interface

The IOM-2 interface can be switched off in the inactive state, reducing power consumption to a minimum. In this deactivated state is FSC = '1', DCL and BCL = '0' and the data lines are '1'.

The IOM-2 interface can be kept active while the S interface is deactivated by setting the CFS bit to "0" (MODE1 register). This is the case after a hardware reset. If the IOM-2 interface should be switched off while the S interface is deactivated, the CFS bit should be set to '1'. In this case the internal oscillator is disabled when no signal (info 0) is present on the S bus and the C/I command is '1111' = DIU. If the TE wants to activate the line, it has first to activate the IOM-2 interface either by using the "Software Power Up" function (IOM_CR.SPU bit) or by setting the CFS bit to "0" again.

The deactivation procedure is shown in **Figure 58**. After detecting the code DIU (Deactivate Indication Upstream) the layer 1 of the ISAC-SX TE responds by transmitting DID (Deactivate Indication Downstream) during subsequent frames and stops the timing signals synchronously with the end of the last C/I (C/I0) channel bit of the fourth frame.

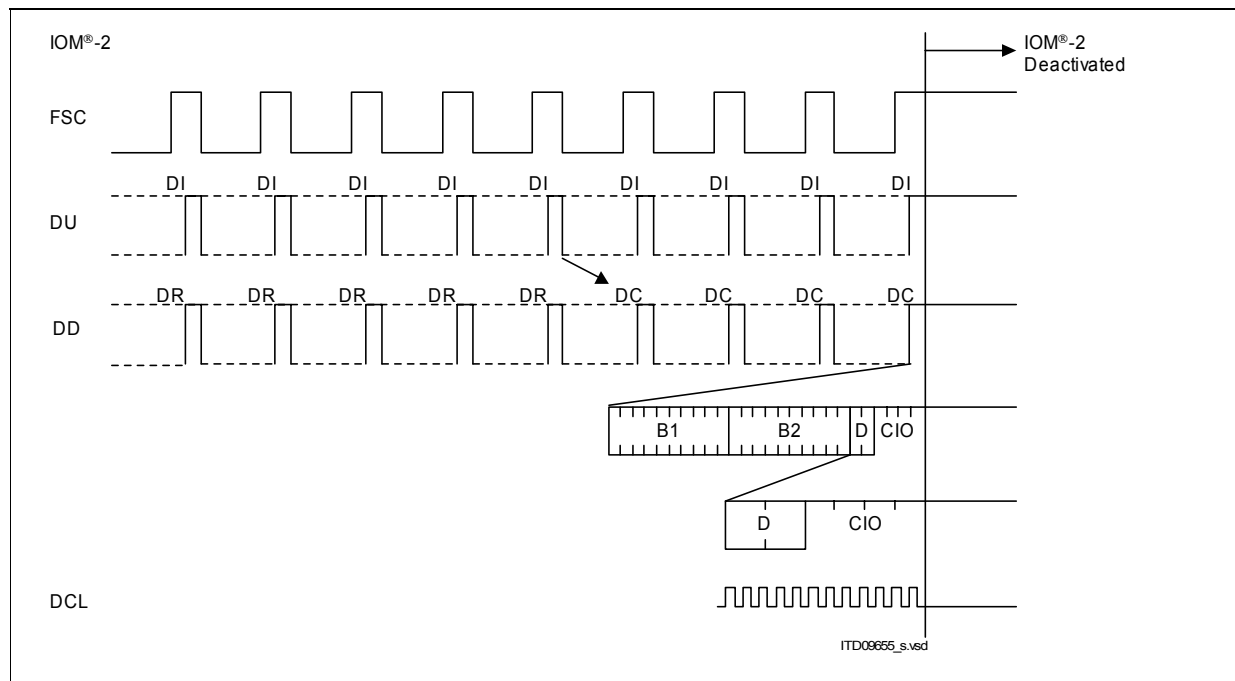

Figure 58 Deactivation of the IOM-2 Interface

The clock pulses will be enabled again when the DU line is pulled low (bit SPU in the IOM_CR register), i.e. the C/I command TIM = "0000" is received by layer 1, or when a non-zero level on the S-line interface is detected (if TR_CONF0.LDD=0). The clocks are turned on after approximately 0.2 to 4 ms depending on the oscillator.

DCL is activated such that its first rising edge occurs with the beginning of the bit following the C/I (C/I0) channel.

Description of Functional Blocks

After the clocks have been enabled this is indicated by the PU code in the C/I channel and, consequently, by a CIC interrupt. The DU line may be released by resetting the Software Power Up bit IOM_CR = '0' and the C/I code written to CIX0 before (e.g. TIM or AR8) is output on DU.

The ISAC-SX TE supplies IOM-2 timing signals as long as there is no DIU command in the C/I (C/I0) channel. If timing signals are no longer required and activation is not yet requested, this is indicated by programming DIU in the CIX0 register.

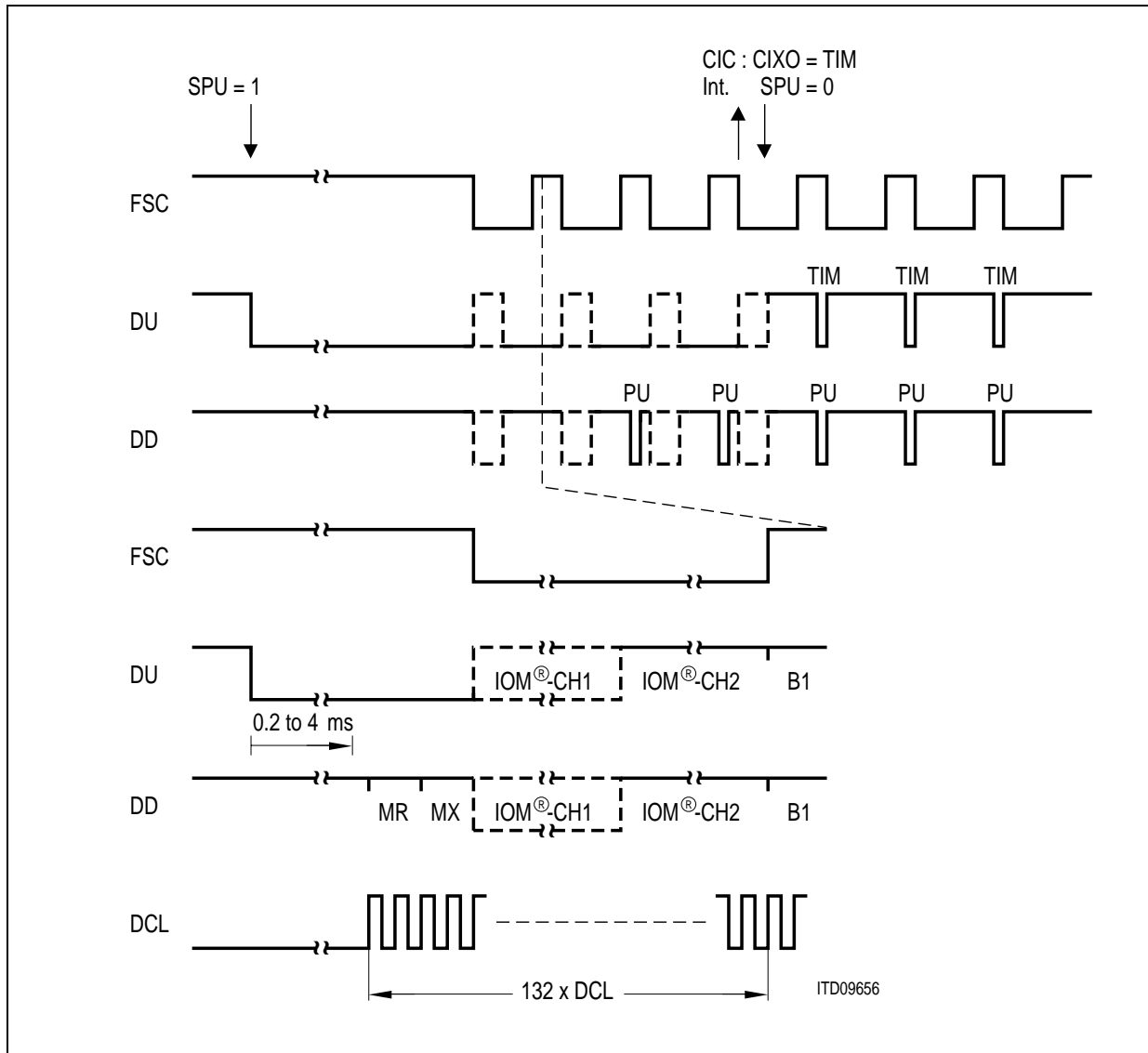

Figure 59 Activation of the IOM-2 interface

3.8 HDLC Controller

The ISAC-SX TE contains an HDLC controller for the layer-2 functions of the D- channel protocol (LAPD). By setting the Enable HDLC channel bits (D_EN_x) in the DCI_CR register the HDLC controller can access the D or B-channels on IOM-2.

It performs the framing functions used in HDLC based communication: flag generation/ recognition, bit stuffing, CRC check and address recognition.

The FIFO has a size of 64 byte per direction and is implemented as cyclic buffers. The transceiver reads and writes data sequentially with constant data rate whereas the data transfer between FIFO and microcontroller uses a block oriented protocol with variable block sizes.

The configuration, control and status bits related to the HDLC controller are all assigned to the following address ranges:

Table 14 HDLC Controller Address Range

	FIFO Address	Config/Ctrl/Status Registers
D-channel HDLC	00 _H -1F _H	20 _H -29 _H

Note: For D-channel access the address range 00_H-1F_H is used (similar as in ISAC-S TE PSB 2186), however a single address from this range is sufficient to access the FIFO as the internal FIFO pointer is incremented automatically independent from the external address.

3.8.1 Message Transfer Modes

The HDLC controller can be programmed to operate in various modes, which are different in the treatment of the HDLC frame in receive direction. Thus the receive data flow and the address recognition features can be programmed in a flexible way to satisfy different system requirements.

The structure of a D-channel two-byte address (LAPD) is shown below:

High Address Byte		Low Address Byte	
SAPI1, 2, SAPG	C/R 0	TEI 1, 2, TEIG	EA

For address recognition on the D-channel the ISAC-SX TE contains four programmable registers for individual SAPI and TEI values (SAP1, 2 and TEI1, 2), plus two fixed values for the “group” SAPI (SAPG = 'FE' or 'FC') and TEI (TEIG = 'FF').

The received C/R bit is excluded from the address comparison. EA is the address field extension bit which must be set to '1' according to HDLC LAPD.

Description of Functional Blocks**Operating Modes**

There are 5 different operating modes which can be selected via the mode selection bits MDS2-0 in the MODED registers:

Non-Auto Mode (MDS2-0 = '01x')

Characteristics: Full address recognition with one-byte (MDS = '010') or two-byte (MDS = '011') address comparison

All frames with valid addresses are accepted and the bytes following the address are transferred to the μ P via RFIFOD. Additional information is available in RSTAD.

Transparent mode 0 (MDS2-0 = '110').

Characteristics: no address recognition

Every received frame is stored in RFIFOD (first byte after opening flag to CRC field). Additional information can be read from RSTAD.

Transparent mode 1 (MDS2-0 = '111').

Characteristics: SAPI recognition

A comparison is performed on the first byte after the opening flag with SAP1, SAP2 and "group" SAPI (FE_H/FC_H). In the case of a match, all the following bytes are stored in RFIFOD. Additional information can be read from RSTAD.

Transparent mode 2 (MDS2-0 = '101').

Characteristics: TEI recognition

A comparison is performed only on the second byte after the opening flag, with TEI1, TEI2 and group TEI (FF_H). In case of a match the rest of the frame is stored in the RFIFOD. Additional information is available in RSTAD.

Extended transparent mode (MDS2-0 = '100').

Characteristics: fully transparent

In extended transparent mode fully transparent data transmission/reception without HDLC framing is performed i.e. without FLAG generation/recognition, CRC generation/check, bitstuffing mechanism. This allows user specific protocol variations.

Also refer to [Chapter 3.8.5](#).

3.8.2 Data Reception

3.8.2.1 Structure and Control of the Receive FIFO

The cyclic receive FIFO buffer with a length of 64 byte has a variable FIFO block size (threshold) of 4, 8, 16 or 32 bytes which can be selected by setting the corresponding RFBS bits in the EXMD register. The variable block size allows an optimized HDLC processing concerning frame length, I/O throughput and interrupt load.

The transfer protocol between HDLC FIFO and microcontroller is block oriented with the microcontroller as master. The control of the data transfer between the CPU and the ISAC-SX TE is handled via interrupts (ISAC-SX TE → Host) and commands (Host → ISAC-SX TE).

There are three different interrupt indications in the ISTAD registres concerned with the reception of data:

- **RPF (Receive Pool Full)** interrupt, indicating that a data block of the selected length (EXMD.RFBS) can be read from RFIFOD. The message which is currently received exceeds the block size so further blocks will be received to complete the message.
- **RME (Receive Message End)** interrupt, indicating that the reception of one message is completed, i.e. either
 - a short message is received (message length \leq the defined block size (EXMD.RFBS)) or
 - the last part of a long message is received (message length $>$ the defined block size (EXMD.RFBS)) and is stored in the RFIFOx.
- **RFO (Receive Frame Overflow)** interrupt, indicating that a complete frame could not be stored in RFIFOD and is therefore lost as the RFIFOD is occupied. This occurs if the host fails to respond quickly enough to RPF/RME interrupts since previous data was not read by the host.

There are two control commands that are used with the reception of data:

- **RMC (Receive Message Complete)** command, telling the ISAC-SX TE that a data block has been read from the RFIFOD and the corresponding FIFO space can be released for new receive data.
- **RRES (Receiver Reset)** command, resetting the HDLC receiver and clearing the receive FIFO of any data (e.g. used before start of reception). It has to be used after a change of the message transfer mode. Pending interrupt indications of the receiver are not cleared by RRES, but have to be cleared by reading these interrupts.

Note: The significant interrupts and commands are underlined as only these are commonly used during a normal reception sequence.

The following description of the receive FIFO operation is illustrated in **Figure 60** for a RFIFOD block size (threshold) of 16 and 32 bytes.

Description of Functional Blocks

The RFIFOD requests service from the microcontroller by setting a bit in the ISTAD register, which causes an interrupt (RPF, RME, RFO). The microcontroller then reads status information (RBCHD,RBCLD), data from the RFIFOD and then may change the receive FIFO block size (EXMD.RFBS). A block transfer is completed by the microcontroller via a receive message complete (CMDRD.RMC) command. This causes the space of the transferred bytes being released for new data and in case the frame was complete (RME) the reset of the receive byte counter RBC (RBCHD,RBCLD)¹⁾.

The total length of the frame is contained in the RBCHD and RBCLD registers which contain a 12 bit number (RBC11...0), so frames up to 4095 byte length can be counted. If a frame is longer than 4095 bytes, the RBCHD.OV (overflow) bit will be set. The least significant bits of RBCLD contain the number of valid bytes in the last data block indicated by RME (length of last data block \leq selected block size). **Table 15** shows which RBC bits contain the number of bytes in the last data block or number of complete data blocks respectively. If the number of bytes in the last data block is '0' the length of the last received block is equal to the block size.

Table 15 Receive Byte Count with RBC11...0 in the RBCHD/RBCLD Registers

EXMD1.RFBS	Selected block size	Number of	
		complete data blocks in	bytes in the last data block in
'00'	32 byte	RBC11...5	RBC4...0
'01'	16 byte	RBC11...4	RBC3...0
'10'	8 byte	RBC11...3	RBC2...0
'11'	4 byte	RBC11...2	RBC1...0

The transfer block size (EXMD.RFBS) is 32 bytes by default. If it is necessary to react to an incoming frame within the first few bytes the microcontroller can set the RFIFOD block size to a smaller value. Each time a CMDRD.RMC or CMDRD.RRES command is issued, the RFIFOD access controller sets its block size to the value specified in EXMD.RFBS, so the microcontroller has to write the new value for RFBS before the RMC command. When setting an initial value for RFBS before the first HDLC activities, a RRES command must be issued afterwards.

The RFIFOD can hold any number of frames fitting in the 64 bytes. At the end of a frame, the RSTAD byte is always appended.

All generated interrupts are inserted together with all additional information into a wait line to be individually passed to the host. For example if several data blocks have been received to be read by the host and the host acknowledges the current block, a new RPF or RME interrupt from the wait line is immediately generated to indicate new data.

¹⁾ If RMC is omitted, then no new interrupt can be generated.

Description of Functional Blocks

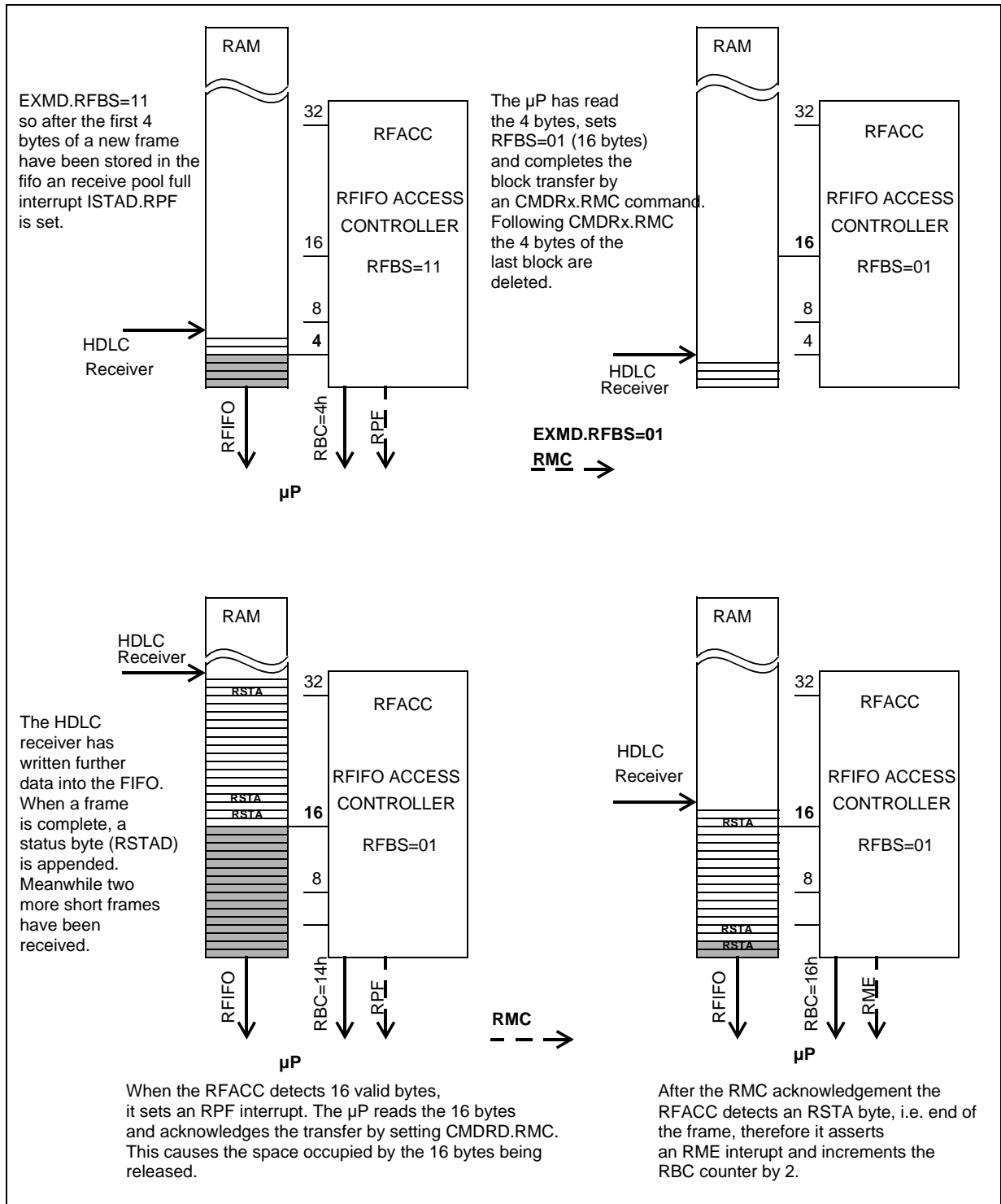

Figure 60 RFIFO Operation

Description of Functional Blocks**Possible Error Conditions During Reception of Frames**

If parts of a frame get lost because the receive FIFO is full, the Receive Data Overflow (RDO) byte in the RSTAD byte will be set. If a complete frame is lost, i.e. if the FIFO is full when a new frame is received, the receiver will assert a Receive Frame Overflow (RFO) interrupt.

The microcontroller sees a cyclic buffer, i.e. if it tries to read more data than available, it reads the same data again and again. On the other hand, if it doesn't read or doesn't want to read all data, they are deleted anyway after the RMC command.

If the microcontroller reads data without a prior RME or RPF interrupt, the content of the RFIFOD would not be corrupted, but new data is only transferred to the host as long as new valid data is available in the RFIFOD, otherwise the last data is read again and again.

The general procedures for a data reception sequence are outlined in the flow diagram in [Figure 61](#).

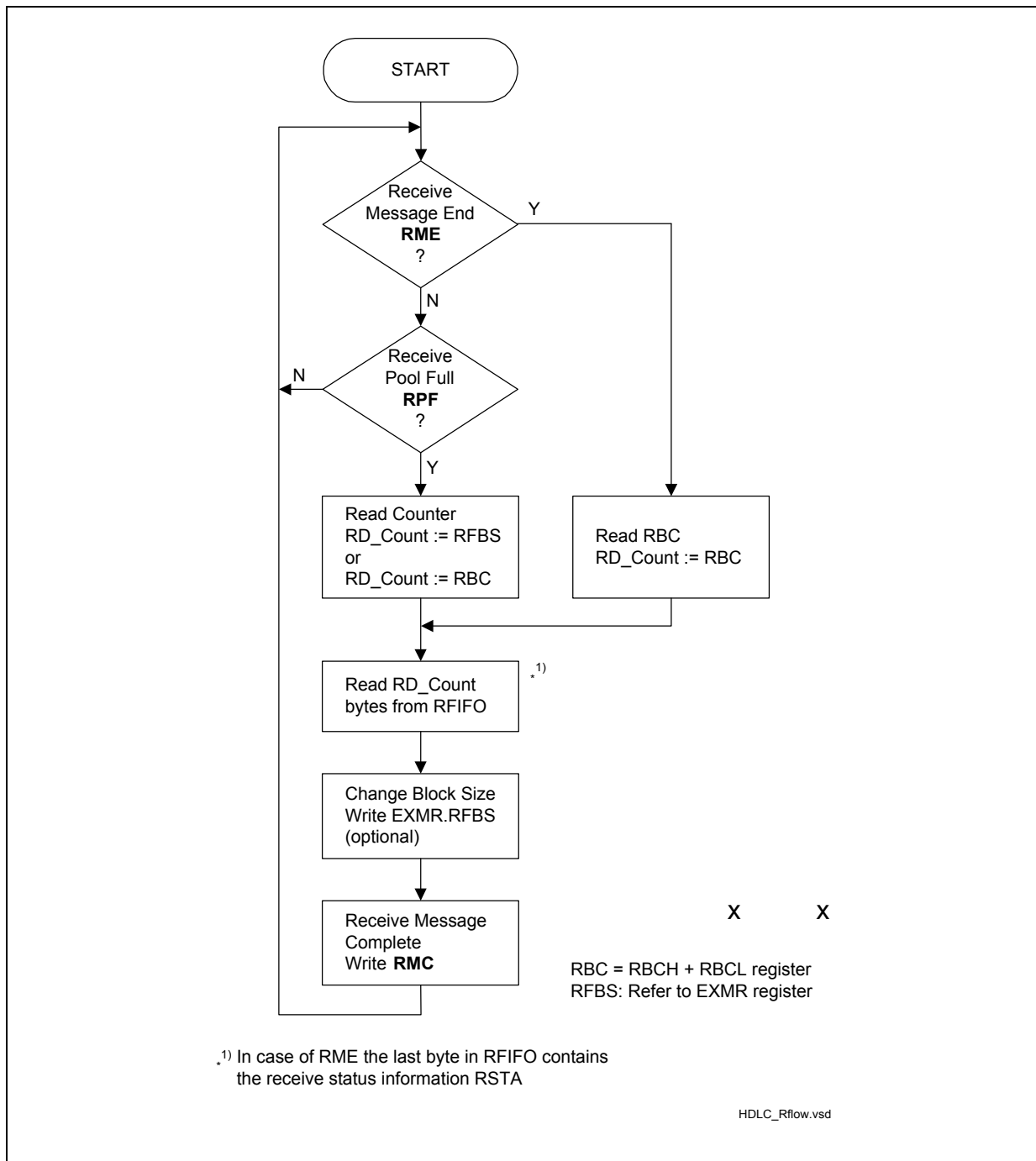

Figure 61 Data Reception Procedures

Figure 62 gives an example of an interrupt controlled reception sequence, supposed that a long frame (68 byte) followed by two short frames (12 byte each) are received. The FIFO threshold (block size) is set to 32 byte in this example:

- After 32 byte of frame 1 have been received an RPF interrupt is generated to indicate that a data block can be read from the RFIFOD.

Description of Functional Blocks

- The host reads the first data block from RFIFOD and acknowledges the reception by RMC. Meanwhile the second data block is received and stored in RFIFOD.
- The second 32 byte block is indicated by RPF which is read and acknowledged by the host as described before.
- The reception of the remaining 4 bytes plus RSTAD are indicated by RME (i.e. the receive status is always appended to the end of the frame).
- The host gets the number of bytes (COUNT = 5) from RBCLD/RBCHD and reads out the RFIFOD and optionally the status register RSTA. The frame is acknowledged by RMC.
- The second frame is received and indicated by RME interrupt.
- The host gets the number of bytes (COUNT = 13) from RBCLD/RBCHD and reads out the RFIFOD and optionally the status register. The RFIFOD is acknowledged by RMC.
- The third frame is transferred in the same way.

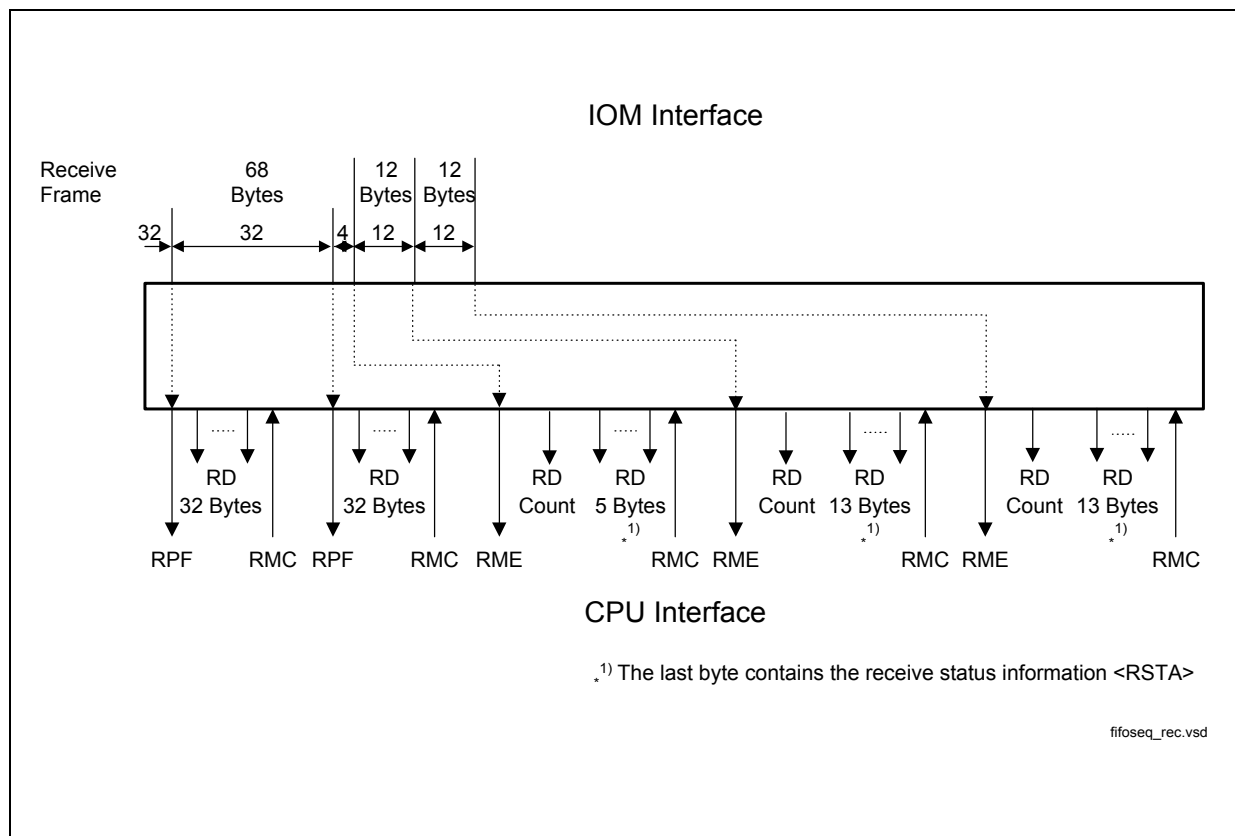

Figure 62 Reception Sequence Example

3.8.2.2 Receive Frame Structure

The management of the received HDLC frames as affected by the different operating modes (see [Chapter 3.8.1](#)) is shown in [Figure 63](#).

Description of Functional Blocks

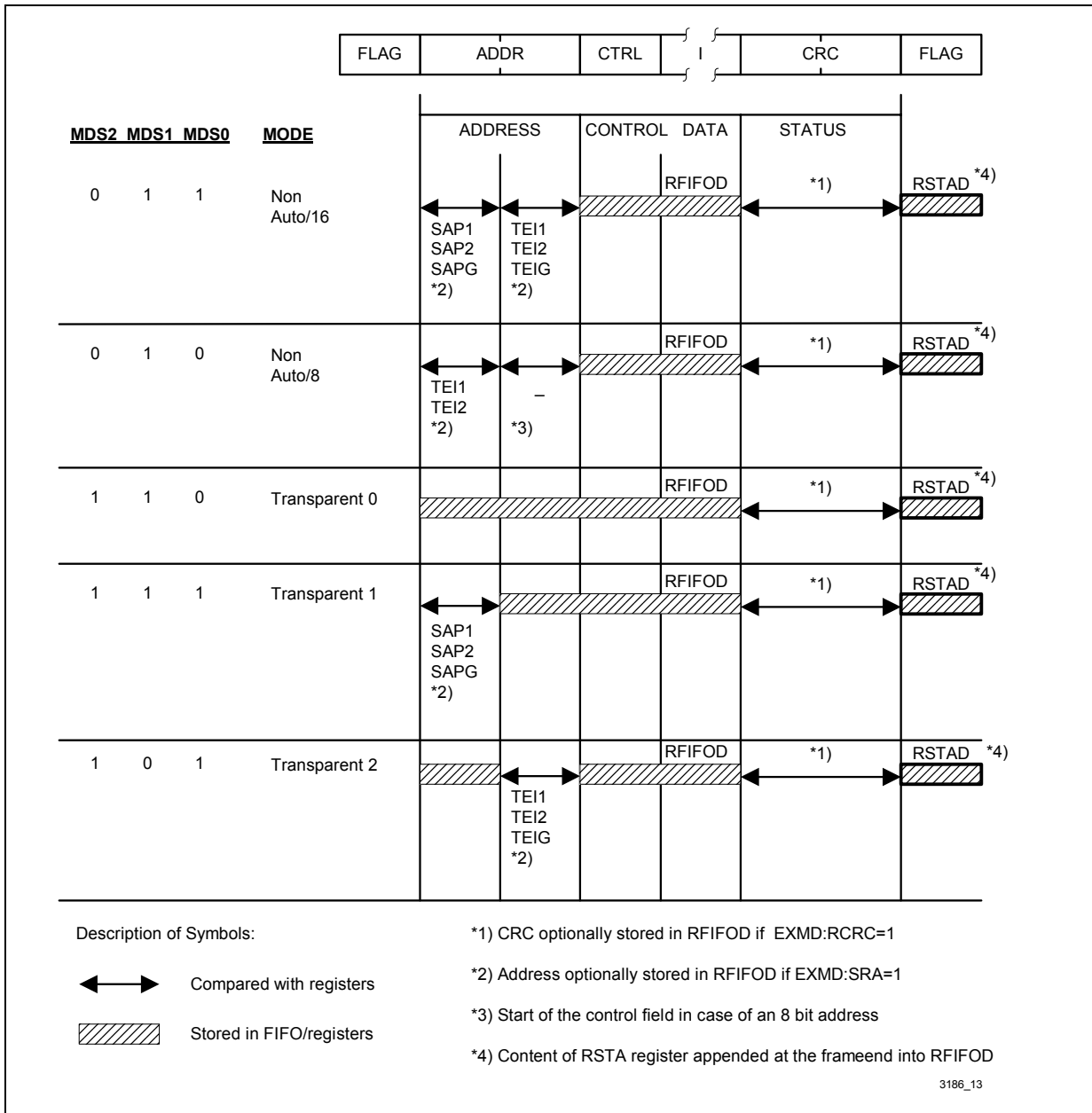

Figure 63 Receive Data Flow

The ISAC-SX TE indicates to the host that a new data block can be read from the RFIFOD by means of an RPF interrupt (see previous chapter). User data is stored in the RFIFOD and information about the received frame is available in the RBCLD and RBCHD registers and the RSTAD byte which are listed in [Table 16](#).

The RSTAD register is always appended in the RFIFOD as last byte to the end of a frame.

Note: The number of bytes received in RFIFOD depends on the selected receive FIFO threshold (EXMD.RFBS).

Description of Functional Blocks

Table 16 Receive Information at RME Interrupt

Information	Register	Bit	Mode
Type of frame (Command/ Response)	RSTAD	C/R	Non-auto mode, 2-byte address field Transparent mode 1
Recognition of SAPI	RSTAD	SA1, 0	Non-auto mode, 2-byte address field Transparent mode 1
Recognition of TEI	RSTAD	TA	All except transparent mode 0
Result of CRC check (correct/incorrect)	RSTAD	CRC	All
Valid Frame	RSTAD	VFR	All
Abort condition detected (yes/no)	RSTAD	RAB	All
Data overflow during reception of a frame (yes/no)	RSTAD	RDO	All
Number of bytes received in RFIFO	RBCL	RBC4-0	All
Message length	RBCLD RBCHD	RBC11-0	All
RFIFO Overflow	RBCHD	OV	All

3.8.3 Data Transmission

3.8.3.1 Structure and Control of the Transmit FIFO

The cyclic transmit FIFO buffer with a length of 64 byte has a variable FIFO block size (threshold) of 16 or 32 bytes (programmable) which can be selected by setting the corresponding XFBS bits in the EXMD register. There are three different interrupt indications in the ISTAD register concerned with the transmission of data:

- **XPR (Transmit Pool Ready)** interrupt, indicating that a data block of up to 16 or 32 byte can be written to the XFIFOD (fixed block size).
An XPR interrupt is generated either
 - after an XRES (Transmitter Reset) command (which is issued for example for frame abort) or
 - when a data block from the XFIFOD is transmitted and the corresponding FIFO space is released to accept further data from the host.
- **XDU (Transmit Data Underrun)** interrupt, indicating that the transmission of the current frame has been aborted (seven consecutive '1's are transmitted) as the XFIFOD holds no further transmit data. This occurs if the host fails to respond to an XPR interrupt quickly enough.
- **XMR (Transmit Message Repeat)** interrupt, indicating that the transmission of the complete last frame has to be repeated as a collision on the S bus has been detected and the XFIFOx does not hold the first data bytes of the frame (collision after the 16th/32nd byte or after the 32nd byte of the frame, respectively).

The occurrence of an XDU or XMR interrupt clears the XFIFOD and an XMR interrupt is issued together with an XDU or XMR interrupt, respectively. Data cannot be written to the XFIFOD as long as an XDU/XMR interrupt is pending.

Three different control commands are used for transmission of data:

- **XTF (Transmit Transparent Frame)** command, telling the ISAC-SX TE that up to 16 or 32 byte have been written to the XFIFOD and should be transmitted. A start flag is generated automatically.
- **XME (Transmit Message End)** command, telling the ISAC-SX TE that the last data block written to the XFIFOD completes the corresponding frame and should be transmitted. This implies that according to the selected mode a frame end (CRC + closing flag) is generated and appended to the frame.
- **XRES (Transmitter Reset)** command, resetting the HDLC transmitter and clearing the transmit FIFO of any data. After an XRES command the transmitter always sends an abort sequence, i.e. this command can be used to abort a transmission. Pending interrupt indications of the transmitter are not cleared by XRES, but have to be cleared by reading these interrupts.

Optionally two additional status conditions can be read by the host:

Description of Functional Blocks

- **XDOV** (Transmit **D**ata **O**verflow), indicating that the data block size has been exceeded, i.e. more than 16 or 32 byte were entered and data was overwritten.
- **XFW** (Transmit **F**IFO **W**rite Enable), indicating that data can be written to the XFIFOD. This status flag may be polled instead of or in addition to XPR.

Note: The significant interrupts and commands are underlined as only these are usually used during a normal transmission sequence.

The XFIFOD requests service from the microcontroller by setting a bit in the ISTAD register, which causes an interrupt (XPR, XDU, XMR). The microcontroller can then read the status register STARD (XFW, XDOV), write data in the FIFO and it can change the transmit FIFO block size (EXMD.XFBS) if required.

The instant of the initiation of a transmit pool ready (XPR) interrupt after different transmit control commands is listed in [Table 17](#).

Table 17 XPR Interrupt (availability of XFIFOD) after XTF, XME Commands

CMDRD Register	Transmit pool ready (XPR) interrupt initiated ...
XTF	as soon as the selected buffer size in the XFIFOD is available.
XTF & XME	after the successful transmission of the closing flag. The transmitter always sends an abort sequence.
XME	as soon as the selected buffer size in the FIFO is available, two consecutive frames share flags.

When setting XME the transmitter appends the CRC and the endflag at the end of the frame. When XTF & XME has been set, the XFIFOD is locked until successful transmission of the current frame, so a consecutive XPR interrupt also indicates successful transmission of the frame whereas after XME or XTF the XPR interrupt is asserted as soon as there is space for one data block in the XFIFOD.

The transfer block size is 32 bytes for D- and B-channel by default, but sometimes, if the microcontroller has a high computational load, it is useful to increase the maximum reaction time for an XPR interrupt. However, the threshold can only be changed for D-channel. The maximum reaction time is:

$$t_{\max} = (\text{XFIFOD size} - \text{XFBS}) / \text{data transmission rate}$$

With a selected block size of 16 bytes an XPR interrupt indicates when a transmit FIFO space of at least 16 bytes is available to accept further data, i.e. there are still a maximum of 48 bytes (64 bytes - 16 bytes) to be transmitted. With a 32 bytes block size the XPR is initiated when a transmit FIFO space of at least 32 bytes is available to accept further data, i.e. there are still a maximum of 32 bytes (64 bytes - 32 bytes) to be transmitted. The maximum reaction time for the smaller block size is 50 % higher with the trade-off of a doubled interrupt load. With a selected block size an XPR always indicates the

Description of Functional Blocks

available space in the XFIFOD, so any number of bytes smaller than the selected XFBS may be stored in the FIFO during one “write block“ access cycle.

Similar to RFBS for the receive FIFO, a new setting of XFBS takes effect after the next XTF, XME or XRES command. XRES resets the XFIFOD.

The XFIFOD can hold any number of frames fitting in the 64 bytes.

Possible Error Conditions during Transmission of Frames

If the transmitter sees an empty FIFO, i.e. if the microcontroller doesn't react fast enough to an XPR interrupt, an XDU (transmit data underrun) interrupt will be generated. If the HDLC channel becomes unavailable during transmission the transmitter tries to repeat the current frame as specified in the LAPD protocol. This is impossible after the first data block has been sent (16 or 32 bytes), in this case an XMR transmit message repeat interrupt is set and the microcontroller has to send the whole frame again.

Both XMR and XDU interrupts cause a reset of the XFIFOD. The XFIFOD is locked while an XMR or XDU interrupt is pending, i.d. all write actions of the microcontroller will be ignored as long as the microcontroller hasn't read the ISTAD register with the set XDU, XMR interrupts.

If the microcontroller writes more data than allowed (block size), then the data in the XFIFOD will be corrupted and the STARD.XDOV bit is set. If this happens, the microcontroller has to abort the transmission by CMDRD.XRES and start new.

The general procedures for a data transmission sequence are outlined in the flow diagram in [Figure 64](#).

Description of Functional Blocks

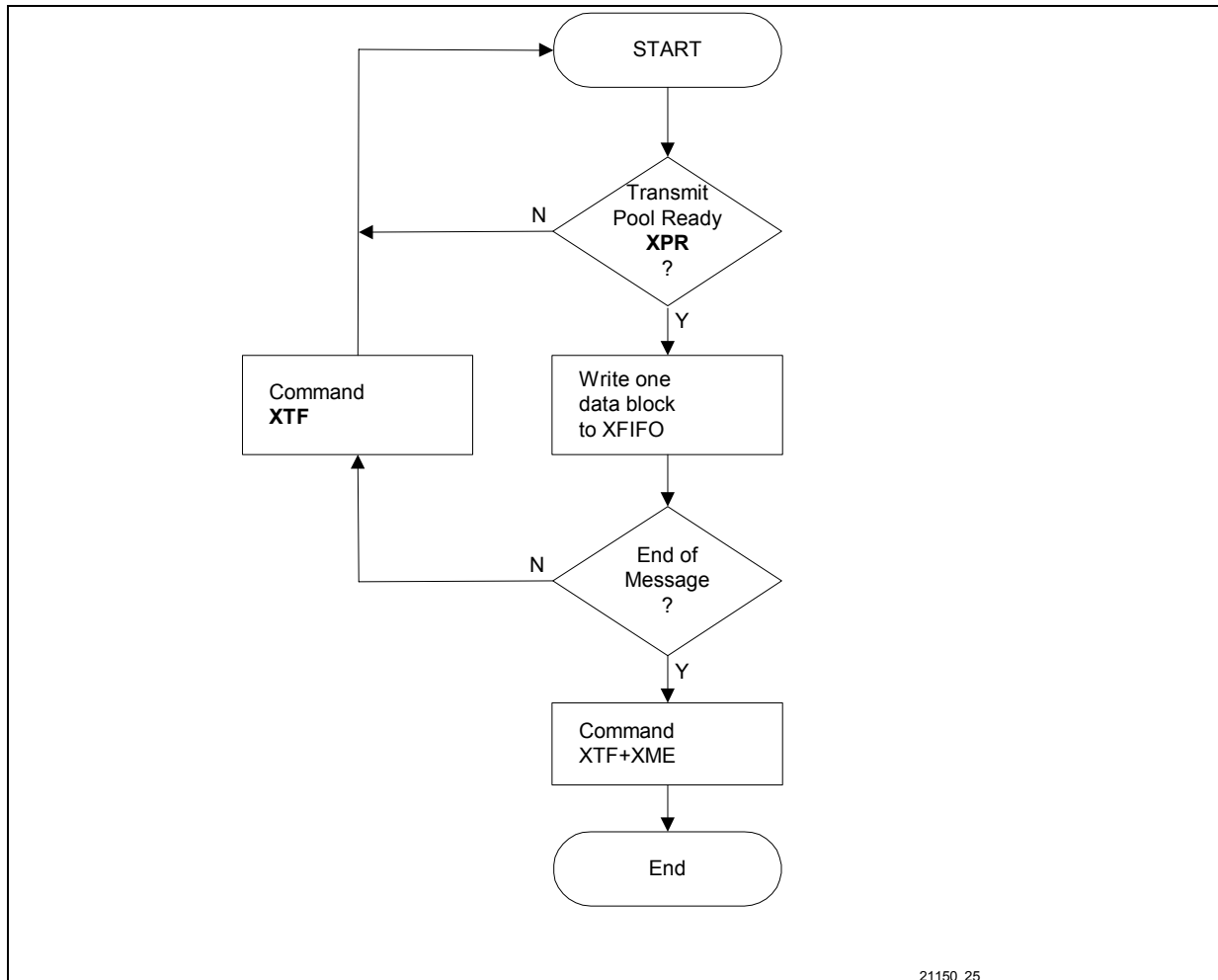

Figure 64 Data Transmission Procedure

The following description gives an example for the transmission of a 76 byte frame with a selected block size of 32 byte:

- The host writes 32 bytes to the XFIFOD, issues an XTF command and waits for an XPR interrupt in order to continue with entering data.
- The ISAC-SX TE immediately issues an XPR interrupt (as remaining XFIFOD space is not used) and starts transmission.
- Due to the XPR interrupt the host writes the next 32 bytes to the XFIFOD, followed by the XTF command, and waits for XPR.
- As soon as the last byte of the first block is transmitted, the ISAC-SX TE releases an XPR (XFIFOD space of first data block is free again) and continues transmitting the second block.
- The host writes the remaining 12 bytes of the frame to the XFIFOD and issues the XTF command together with XME to indicate that this is the end of frame.
- After the last byte of the frame has been transmitted the ISAC-SX TE releases an XPR interrupt and the host may proceed with transmission of a new frame.

Description of Functional Blocks

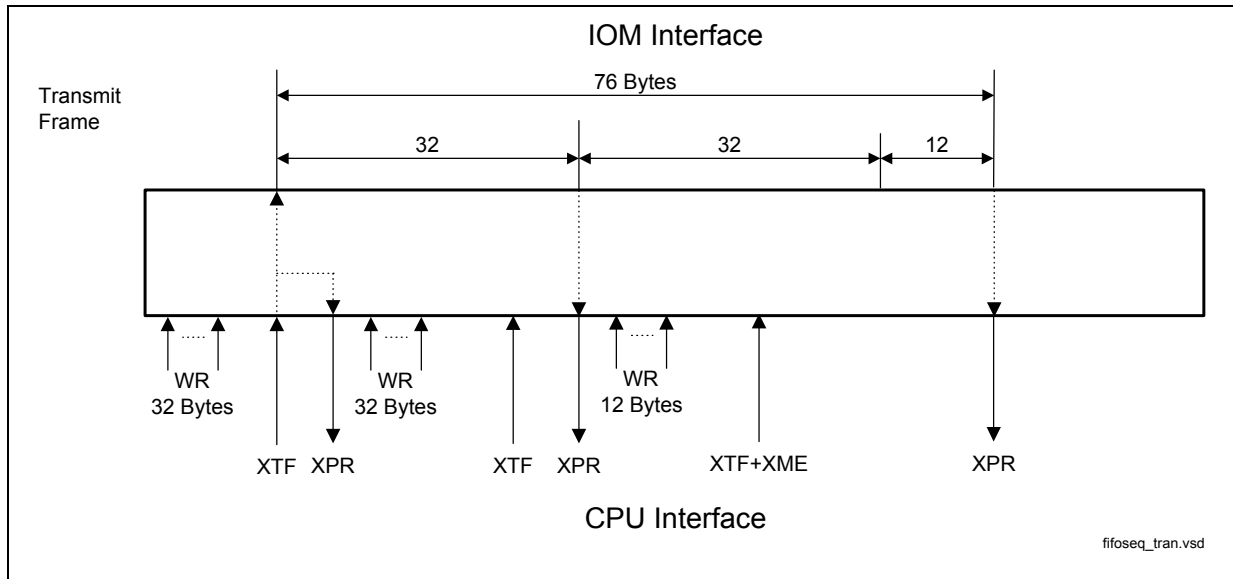

Figure 65 Transmission Sequence Example

3.8.3.2 Transmit Frame Structure

The transmission of transparent frames (XTF command) is shown in [Figure 66](#).

For transparent frames, the whole frame including address and control field must be written to the XFIFOD. The host configures whether the CRC is generated and appended to the frame (default) or not (selected in EXMD.XCRC).

Further, the host selects the interframe time fill signal which is transmitted between HDCL frames (EXMD.ITF). One option is to send continuous flags ('01111110'), however if D-channel access handling (collision resolution on the S bus) is required, the signal must be set to idle (continuous '1's are transmitted). Reprogramming of ITF takes effect only after the transmission of the current frame has been completed or after an XRES command.

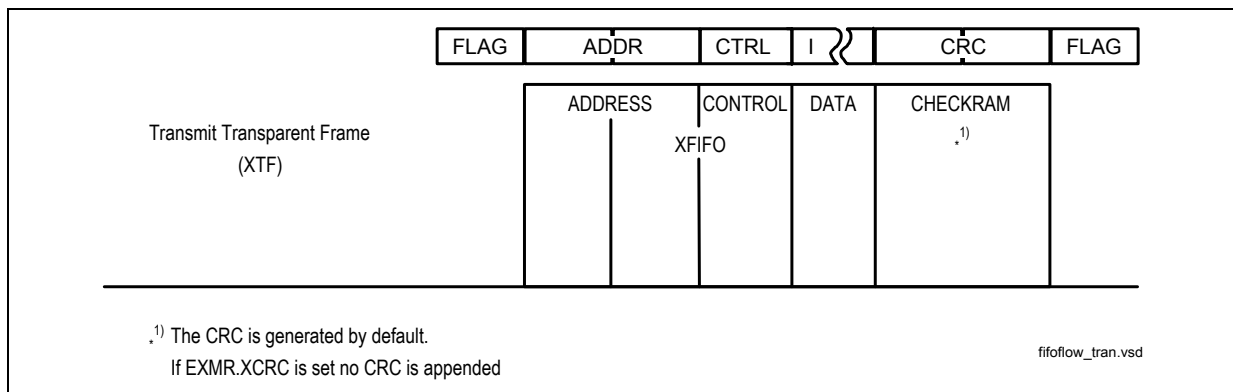

Figure 66 Transmit Data Flow

3.8.4 Access to IOM-2 Channels

By setting the enable HDLC data bits (D_EN_D, D_EN_B1, D_EN_B2) in the DCI_CR register the HDLC controller can access the D, B1 and B2 channels or any combination of them. In all modes (except extended transparent mode) transmission always works frame aligned, i.e. it starts with the first selected channel, whereas reception searches for a flag anywhere in the serial data stream.

3.8.5 Extended Transparent Mode

This non-HDLC mode is selected by setting MODE2...0 to '100'. In extended transparent mode fully transparent data transmission/reception without HDLC framing is performed i.e. without FLAG generation/recognition, CRC generation/check, bitstuffing mechanism. This allows user specific protocol variations.

Transmitter

The transmitter sends the data out of the FIFO without manipulation. Transmission is always IOM-2 frame aligned and byte aligned, i.e. transmission starts in the first selected channel (B1, B2, D, according to the setting of register DCI_CR in the IOM-2 Handler) of the next IOM-2 frame.

The FIFO indications and commands are the same as in other modes.

If the microcontroller sets XTF & XME the transmitter responds with an XPR interrupt after sending the last byte, then it returns to its idle state (sending continuous '1').

If the collision detection is enabled in D-channel (MODE.DIM = '0x1') the stop go bit (S/G) can be used as clear to send indication as in any other mode. If the S/G bit is set to '1' (stop) during transmission the transmitter responds always with an XMR (transmit message repeat) interrupt.

If the microcontroller fails to respond to a XPR interrupt in time and the transmitter runs out of data then it will assert an XDU (transmit data underrun) interrupt.

Receiver

The reception is IOM-2 frame aligned and byte aligned, like transmission, i.e. reception starts in the first selected channel (B1, B2, D, according to the setting of registers DCI_CR in the IOM-2 Handler) of the next IOM-2 frame. The FIFO indications and commands are the same as in others modes.

All incoming data bytes are stored in the RFIFOD and is additionally made available in RSTAD. If the FIFO is full an RFO interrupt is asserted (EXMD.SRA = '0').

Note: In the extended transparent mode the EXMD register has to be set to 'xxx00000'

3.8.6 HDLC Controller Interrupts

The cause of an interrupt related to the HDLC controller is indicated in the ISTA register by the ICD bit. This bit points to the interrupt source of the D-channel HDLC controller in the ISTAD register. The individual interrupt sources of the HDLC controllers during reception and transmission of data are explained in [Chapter 3.8.2.1](#) or [Chapter 3.8.3.1](#) respectively.

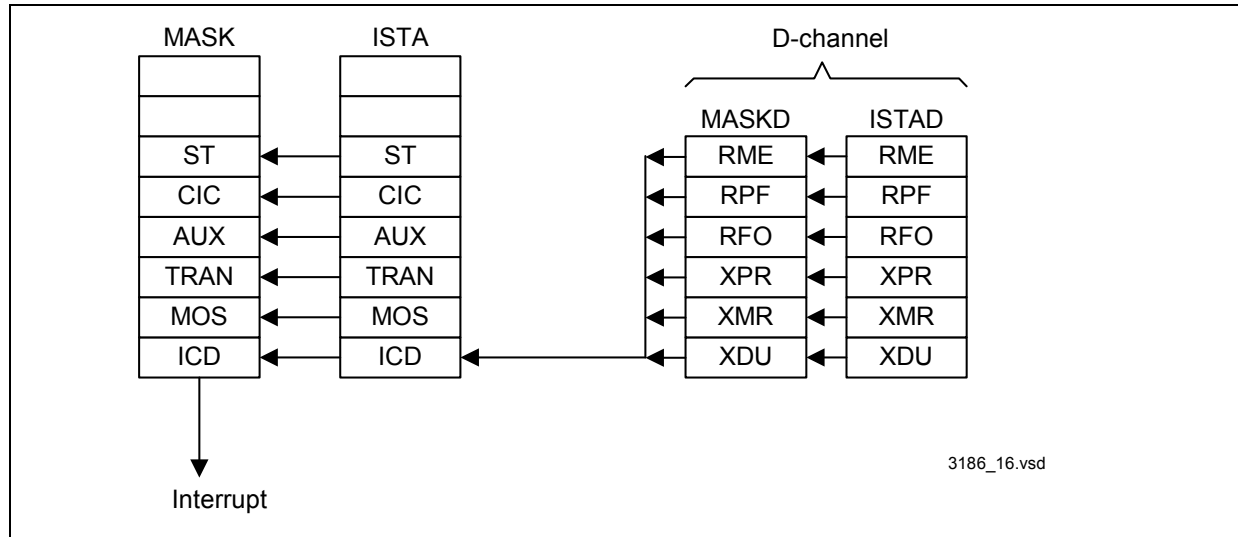

Figure 67 Interrupt Status Registers of the HDLC Controllers

Each interrupt source in the ISTAD register can selectively be masked by setting the corresponding bit in MASKD to "1".

3.9 Test Functions

The ISAC-SX TE provides test and diagnostic functions for the S-interface and the D-channel:

- Digital loop via TLP (Test Loop, TMD register) command bit (**Figure 68**): The TX path of layer 2 is internally connected with the RX path of layer 2. The output from layer 1 (S/T) on DD is ignored. This is used for testing ISAC-SX TE functionality excluding layer 1 (loopback between XFIFOD and RFIFOD).

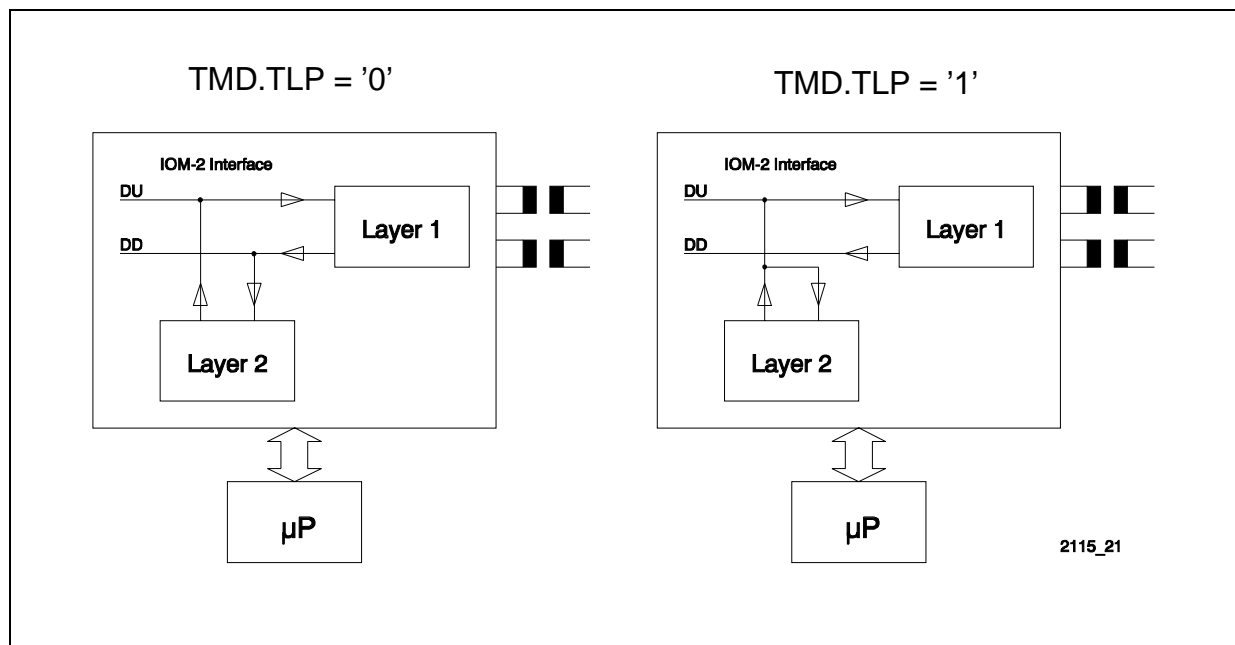

Figure 68 Layer 2 Test Loops

Description of Functional Blocks

- Test of layer-2 functions while disabling all layer-1 functions and pins associated with them (including clocking) via bit TR_CONF0.DIS_TR. The HDLC controllers can still operate via IOM-2. DCL and FSC pins become input.
- loop at the analog end of the S interface;

Test loop 3 is activated with the C/I channel command Activate Request Loop (ARL). An S interface is not required since INFO3 is looped back internally to the receiver. When the receiver has synchronized itself to this signal, the message "Test Indication" (or "Awake Test Indication") is delivered in the C/I channel. No signal is transmitted over the S interface.

In the test loop mode the S interface awake detector is enabled, i.e. if a level is detected (e.g. Info 2/Info 4) this will be reported by the Resynchronization Indication (RSY). The loop function is not effected by this condition and the internally generated 192-kHz line clock does not depend on the signal received at the S interface.

- transmission of special test signals on the S/T interface according to the modified AMI code are initiated via a C/I command written in CIX0 register.

Two kinds of test signals may be sent by the ISAC-SX TE:

- single pulses and
- continuous pulses.

The single pulses are of alternating polarity, one S interface bit period wide, 0.25 ms apart, with a repetition frequency of 2 kHz. Single pulses can be sent in all applications. The corresponding C/I command in TE applications is TM1.

Continuous pulses are likewise of alternating polarity, one S-interface bit period wide, but they are sent continuously. The repetition frequency is 96 kHz. Continuous pulses may be transmitted in all applications. This test mode is entered in TE applications with the C/I command TM2.

4 Detailed Register Description

The register mapping of the ISAC-SX TE is shown in [Figure 69](#).

FFh	(Not used)
70h	
60h	Interrupt, General Configuration
40h	IOM-2 and MONITOR Handler
30h	Transceiver
00h	D- and C/I-channel

3186_04

Figure 69 Register Mapping of the ISAC-SX TE

The register address range from 00_H-2F_H is assigned to the D-channel HDLC controller and the C/I-channel handler.

The register set ranging from 30_H-3F_H pertains to the transceiver registers.

The address range from 40_H-5B_H is assigned to the IOM handler with the registers for timeslot and data port selection (TSDP) and the control registers (CR) for the transceiver data (TR), Monitor data (MON), HDLC/CI data (HCI) and controller access data (CDA), serial data strobe signal (SDS), IOM interface (IOM) and synchronous transfer interrupt (STI).

The address range from 5C_H-5F_H pertains to the MONITOR handler.

General interrupt and configuration registers are contained in the address range 60_H-65_H.

Detailed Register Description

The register summaries of the ISAC-SX TE are shown in the following tables containing the abbreviation of the register name and the register bits, the register address, the reset values and the register type (Read/Write). A detailed register description follows these register summaries.

The register summaries and the description are sorted in ascending order of the register address.

D-channel HDLC, C/I-channel Handler

Name	7	6	5	4	3	2	1	0	ADDR	R/W	RES
RFIFOD	D-Channel Receive FIFO								00 _H -1F _H	R	
XFIFOD	D-Channel Transmit FIFO								00 _H -1F _H	W	
ISTAD	RME	RPF	RFO	XPR	XMR	XDU	0	0	20 _H	R	10 _H
MASKD	RME	RPF	RFO	XPR	XMR	XDU	1	1	20 _H	W	FF _H
STARD	XDOV	XFW	0	0	RACI	0	XACI	0	21 _H	R	40 _H
CMDRD	RMC	RRES	0	STI	XTF	0	XME	XRES	21 _H	W	00 _H
MODED	MDS2	MDS1	MDS0	0	RAC	DIM2	DIM1	DIM0	22 _H	R/W	C0 _H
EXMD1	XFBS	RFBS		SRA	XCRC	RCRC	0	ITF	23 _H	R/W	00 _H
TIMR1	CNT			VALUE					24 _H	R/W	00 _H
SAP1	SAPI1						0	MHA	25 _H	W	FC _H
SAP2	SAPI2						0	MLA	26 _H	W	FC _H
RBCLD	RBC7							RBC0	26 _H	R	00 _H
RBCHD	0	0	0	OV	RBC11			RBC8	27 _H	R	00 _H
TEI1	TEI1							EA1	27 _H	W	FF _H
TEI2	TEI2							EA2	28 _H	W	FF _H
RSTAD	VFR	RDO	CRC	RAB	SA1	SA0	C/R	TA	28 _H	R	0F _H
TMD	0	0	0	0	0	0	0	TLP	29 _H	R/W	00 _H

Detailed Register Description

	reserved					2A-2D _H		
CIR0	CODR0		CIC0	CIC1	S/G	BAS	2E _H	R F3 _H
CIX0	CODX0		TBA2	TBA1	TBA0	BAC	2E _H	W FE _H
CIR1	CODR1				CICW	CI1E	2F _H	R FE _H
CIX1	CODX1				CICW	CI1E	2F _H	W FE _H

Transceiver

NAME	7	6	5	4	3	2	1	0	ADDR	R/W	RES
TR_CONF0	DIS_TR	0	EN_ICV	0	0	0	EXLP	LDD	30 _H	R/W	01 _H
TR_CONF1	0	RPLL_ADJ	EN_SFSC	0	0	x	x	x	31 _H	R/W	
TR_CONF2	DIS_TX	PDS	0	RLP	0	0	0	0	32 _H	R/W	80 _H
TR_STA	RINF		SLIP	ICV	0	FSYN	0	LD	33 _H	R	00 _H
	reserved								34 _H		
SQRR1	MSYN	MFEN	0	0	SQR11	SQR12	SQR13	SQR14	35 _H	R	40 _H
SQXR1	0	MFEN	0	0	SQX11	SQX12	SQX13	SQX14	35 _H	W	4F _H
SQRR2	SQR21	SQR22	SQR23	SQR24	SQR31	SQR32	SQR33	SQR34	36 _H	R	00 _H
	reserved								36 _H	W	
SQRR3	SQR41	SQR42	SQR43	SQR44	SQR51	SQR52	SQR53	SQR54	37 _H	R	00 _H
	reserved								37 _H	W	
ISTATR	0	x	x	x	LD	RIC	SQC	SQW	38 _H	R	00 _H
MASKTR	1	1	1	1	LD	RIC	SQC	SQW	39 _H	R/W	FF _H
	reserved								3A _H - 3B _H		

Detailed Register Description
Transceiver

NAME	7	6	5	4	3	2	1	0	ADDR	R/W	RES
ACFG2	0	0	0	0	ACL	LED	0	0	3C _H	R/W	00 _H
	reserved								3D _H - 3F _H		

**IOM Handler (Timeslot , Data Port Selection,
CDA Data and CDA Control Register)**

Name	7	6	5	4	3	2	1	0	ADDR	R/W	RES
CDA10	Controller Data Access Register (CH10)								40 _H	R/W	FF _H
CDA11	Controller Data Access Register (CH11)								41 _H	R/W	FF _H
CDA20	Controller Data Access Register (CH20)								42 _H	R/W	FF _H
CDA21	Controller Data Access Register (CH21)								43 _H	R/W	FF _H
CDA_ TSDP10	DPS	0	0	TSS					44 _H	R/W	00 _H
CDA_ TSDP11	DPS	0	0	TSS					45 _H	R/W	01 _H
CDA_ TSDP20	DPS	0	0	TSS					46 _H	R/W	80 _H
CDA_ TSDP21	DPS	0	0	TSS					47 _H	R/W	81 _H
	reserved								48 _H - 4B _H		
TR_ TSDP_ BC1	DPS	0	0	TSS					4C _H	R/W	
TR_ TSDP_ BC2	DPS	0	0	TSS					4D _H	R/W	

Detailed Register Description

CDA1_CR	0	0	EN_TBM	EN_I1	EN_I0	EN_O1	EN_O0	SWAP	4E _H	R/W	00 _H
CDA2_CR	0	0	EN_TBM	EN_I1	EN_I0	EN_O1	EN_O0	SWAP	4F _H	R/W	00 _H

IOM Handler (Control Registers, Synchronous Transfer Interrupt Control), MONITOR Handler

Name	7	6	5	4	3	2	1	0	ADDR	R/W	RES
TR_CR (CI_CS=0)	EN_D	EN_B2R	EN_B1R	EN_B2X	EN_B1X	CS2-0			50 _H	R/W	
TRC_CR (CI_CS=1)	0	0	0	0	0	CS2-0			50 _H	R/W	
	reserved								51 _H		
	reserved								52 _H		
DCI_CR (CI_CS=0)	DPS_CI1	EN_CI1	D_EN_D	D_EN_B2	D_EN_B1	CS2-0			53 _H	R/W	
DCIC_CR (CI_CS=1)	0	0	0	0	0	CS2-0			53 _H	R/W	
MON_CR	DPS	EN_MON	0	0	0	CS2-0			54 _H	R/W	
SDS_CR	ENS_TSS	ENS_TSS+1	ENS_TSS+3	TSS					55 _H	R/W	00 _H
	reserved								56 _H		
IOM_CR	SPU	0	CI_CS	TIC_DIS	EN_BCL	CLKM	DIS_OD	DIS_IOM	57 _H	R/W	08 _H
STI	STOV_21	STOV_20	STOV_11	STOV_10	STI_21	STI_20	STI_11	STI_10	58 _H	R	00 _H
ASTI	0	0	0	0	ACK_21	ACK_20	ACK_11	ACK_10	58 _H	W	00 _H

Detailed Register Description

MSTI	STOV 21	STOV 20	STOV 11	STOV 10	STI 21	STI 20	STI 11	STI 10	59 _H	R/W	FF _H
SDS_ CONF	0	0	0	0	DIOM_ INV	DIOM_ SDS	0	SDS_ BCL	5A _H	R/W	00 _H
MCDA	MCDA21		MCDA20		MCDA11		MCDA10		5B _H	R	FF _H
MOR	MONITOR Receive Data								5C _H	R	FF _H
MOX	MONITOR Transmit Data								5C _H	W	FF _H
MOSR	MDR	MER	MDA	MAB	0	0	0	0	5D _H	R	00 _H
MOCR	MRE	MRC	MIE	MXC	0	0	0	0	5E _H	R/W	00 _H
MSTA	0	0	0	0	0	MAC	0	TOUT	5F _H	R	00 _H
MCONF	0	0	0	0	0	0	0	TOUT	5F _H	W	00 _H

Interrupt, General Configuration Registers

NAME	7	6	5	4	3	2	1	0	ADDR	R/W	RES
ISTA	0	0	ST	CIC	AUX	TRAN	MOS	ICD	60 _H	R	00 _H
MASK	1	1	ST	CIC	AUX	TRAN	MOS	ICD	60 _H	W	FF _H
AUXI	0	0	EAW	WOV	TIN2	TIN1	0	0	61 _H	R	00 _H
AUXM	1	1	EAW	WOV	TIN2	TIN1	1	1	61 _H	W	FF _H
MODE1	0	0	0	WTC1	WTC2	CFS	RSS2	RSS1	62 _H	R/W	00 _H
MODE2	0	0	0	0	INT_ POL	0	0	PPSDX	63 _H	R/W	00 _H
ID	0	0	DESIGN						64 _H	R	01 _H
SRES	RES_ CI	0	0	RES_ MON	RES_ DCH	RES_ IOM	RES_ TR	RES_ RSTO	64 _H	W	00 _H
TIMR2	TMD	0	CNT						65 _H	R/W	00 _H

Detailed Register Description

Interrupt, General Configuration Registers

NAME	7	6	5	4	3	2	1	0	ADDR	R/W	RES
	reserved								66 _H - 6F _H		

4.1 D-channel HDLC Control and C/I Registers

4.1.1 RFIFOD - Receive FIFO D-Channel

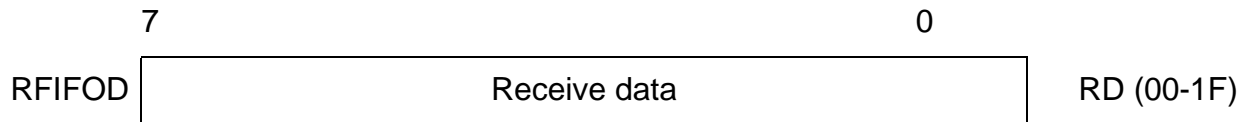

A read access to any address within the range 00h-1Fh gives access to the “current” FIFO location selected by an internal pointer which is automatically incremented after each read access. This allows for the use of efficient “move string” type commands by the microcontroller.

The RFIFOD contains up to 32 bytes of received data.

After an ISTAD.RPF interrupt, a complete data block is available. The block size can be 4, 8, 16 or 32 bytes depending on the EXMD2.RFBS setting.

After an ISTAD.RME interrupt, the number of received bytes can be obtained by reading the RBCLD register.

4.1.2 XFIFOD - Transmit FIFO D-Channel

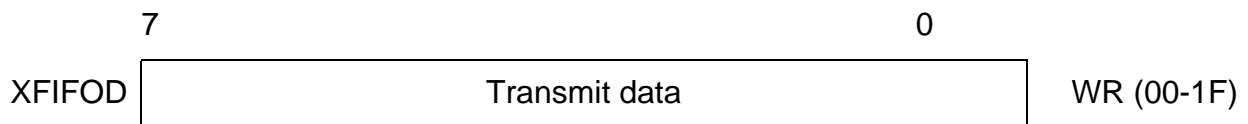

A write access to any address within the range 00-1F_H gives access to the “current” FIFO location selected by an internal pointer which is automatically incremented after each write access. This allows the use of efficient “move string” type commands by the microcontroller.

Depending on EXMD2.XFBS up to 16 or 32 bytes of transmit data can be written to the XFIFOD following an ISTAD.XPR interrupt.

4.1.3 ISTAD - Interrupt Status Register D-Channel

Value after reset: 10_H

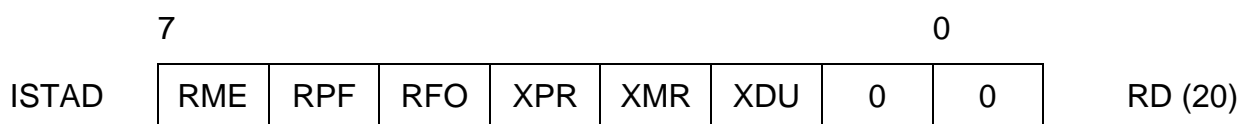

Detailed Register Description**RME ... Receive Message End**

One complete frame of length less than or equal to the defined block size (EXMD1.RFBS) or the last part of a frame of length greater than the defined block size has been received. The contents are available in the RFIFOD. The message length and additional information may be obtained from RBCHD and RBCLD and the RSTAD register.

RPF ... Receive Pool Full

A data block of a frame longer than the defined block size (EXMD1.RFBS) has been received and is available in the RFIFOD. The frame is not yet complete.

RFO ... Receive Frame Overflow

The received data of a frame could not be stored, because the RFIFOD is occupied. The whole message is lost.

This interrupt can be used for statistical purposes and indicates that the microcontroller does not respond quickly enough to an RPF or RME interrupt (ISTAD).

XPR ... Transmit Pool Ready

A data block of up to the defined block size 16 or 32 (EXMD1.XFBS) can be written to the XFIFOD.

An XPR interrupt will be generated in the following cases:

- after an XTF or XME command as soon as the 16 or 32 bytes in the XFIFO are available and the frame is not yet complete
- after an XTF together with an XME command is issued, when the whole frame has been transmitted
- after a reset of the transmitter (XRES)
- after a device reset

XMR ... Transmit Message Repeat

The transmission of the last frame has to be repeated because a collision on the S bus has been detected after the 16th/32nd data byte of a transmit frame.

If an XMR interrupt occurs the transmit FIFO is locked until the XMR interrupt is read by the host (interrupt cannot be read if masked in MASKD).

XDU ... Transmit Data Underrun

The current transmission of a frame is aborted by transmitting seven '1's because the XFIFOD holds no further data. This interrupt occurs whenever the microcontroller has failed to respond to an XPR interrupt (ISTAD register) quickly enough, after having initiated a transmission and the message to be transmitted is not yet complete.

Detailed Register Description

If an XDU interrupt occurs the transmit FIFO is locked until the XDU interrupt is read by the host (interrupt cannot be read if masked in MASKD).

4.1.4 MASKD - Mask Register D-Channel

Value after reset: FF_H

	7							0	
MASKD	RME	RPF	RFO	XPR	XMR	XDU	1	1	WR (20)

Each interrupt source in the ISTAD register can selectively be masked by setting the corresponding bit in MASKD to '1'. Masked interrupt status bits are not indicated when ISTAD is read. Instead, they remain internally stored and pending until the mask bit is reset to '0'.

4.1.5 STARD - Status Register D-Channel

Value after reset: 40_H

	7							0	
STARD	XDOV	XFW	0	0	RACI	0	XACI	0	RD (21)

XDOV ... Transmit Data Overflow

More than 16 or 32 bytes (according to selected block size) have been written to the XFIFOD, i.e. data has been overwritten.

XFW ... Transmit FIFO Write Enable

Data can be written to the XFIFOD. This bit may be polled instead of (or in addition to) using the XPR interrupt.

RACI ... Receiver Active Indication

The D-channel HDLC receiver is active when RACI = '1'. This bit may be polled. The RACI bit is set active after a begin flag has been received and is reset after receiving an abort sequence.

XACI ... Transmitter Active Indication

The D-channel HDLC-transmitter is active when XACI = '1'. This bit may be polled. The XACI-bit is active when an XTF-command is issued and the frame has not been completely transmitted

4.1.6 CMDRD - Command Register D-channel

Value after reset: 00_H

	7							0	
CMDRD	RMC	RRES	0	STI	XTF	0	XME	XRES	WR (21)

RMC ... Receive Message Complete

Reaction to RPF (Receive Pool Full) or RME (Receive Message End) interrupt. By setting this bit, the microcontroller confirms that it has fetched the data, and indicates that the corresponding space in the RFIFOD may be released.

RRES ... Receiver Reset

HDLC receiver is reset, the RFIFOD is cleared of any data.

STI ... Start Timer 1

The ISAC-SX TE timer 1 is started when STI is set to one. The timer is stopped by writing to the TIMR1 register.

Note: Timer 2 is controlled by the TIMR2 register only.

XTF ... Transmit Transparent Frame

After having written up to 16 or 32 bytes (EXMD1.XFBS) to the XFIFOD, the microcontroller initiates the transmission of a transparent frame by setting this bit to '1'. The opening flag is automatically added to the message by the ISAC-SX TE (except in the extended transparent mode where no flags are used).

XME ... Transmit Message End

By setting this bit to '1' the microcontroller indicates that the data block written last to the XFIFOD completes the corresponding frame. The ISAC-SX TE terminates the transmission by appending the CRC (if EXMD1.XCRC=0) and the closing flag sequence to the data (except in the extended transparent mode where no such framing is used).

XRES ... Transmitter Reset

The D-channel HDLC transmitter is reset and the XFIFOD is cleared of any data. This command can be used by the microcontroller to abort a frame currently in transmission.

Note: After an XPR interrupt further data has to be written to the XFIFOD and the appropriate Transmit Command (XTF) has to be written to the CMDRD register again to continue transmission, when the current frame is not yet complete (see also XPR in ISTAD).

During frame transmission, the 0-bit insertion according to the HDLC bit-stuffing mechanism is done automatically.

4.1.7 MODED - Mode Register

Value after reset: C0_H

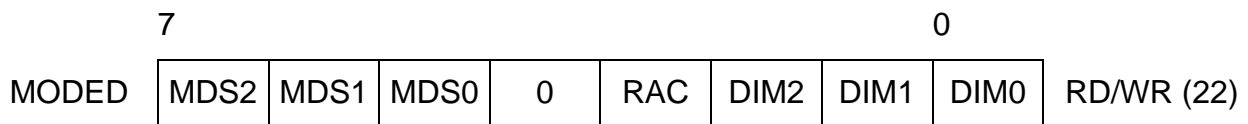

MDS2-0 ... Mode Select

Determines the message transfer mode of the HDLC controller, as follows:

MDS2-0	Mode	Number of Address Bytes	Address Comparison		Remark
			1.Byte	2.Byte	
0 0 0	Reserved				
0 0 1	Reserved				
0 1 0	Non-Auto mode	1	TEI1,TEI2	–	One-byte address compare.
0 1 1	Non-Auto mode	2	SAP1,SAP2, SAPG	TEI1,TEI2,TEIG	Two-byte address compare.
1 0 0	Extended transparent mode				
1 1 0	Transparent mode 0	–	–	–	No address compare. All frames accepted.

Detailed Register Description

MDS2-0	Mode	Number of Address Bytes	Address Comparison		Remark
			1.Byte	2.Byte	
1 1 1	Transparent mode 1	> 1	SAP1,SAP2,SAPG	–	High-byte address compare.
1 0 1	Transparent mode 2	> 1	–	TEI1,TEI2,TEIG	Low-byte address compare.

Note: SAP1, SAP2: two programmable address values for the first received address byte (in the case of an address field longer than 1 byte); SAPG = fixed value FC / FE_H. TEI1, TEI2: two programmable address values for the second (or the only, in the case of a one-byte address) received address byte; TEIG = fixed value FF_H

Two different methods of the high byte and/or low byte address comparison can be selected by setting SAP1.MHA and/or SAP2.MLA.

RAC ... Receiver Active

The D-channel HDLC receiver is activated when this bit is set to '1'. If set to '0' the HDLC data is not evaluated in the receiver.

DIM2-0 ... Digital Interface Modes

These bits define the characteristics of the IOM Data Ports (DU, DD). The DIM0 bit enables/disables the collision detection. The DIM1 bit enables/disables the TIC bus access. The effect of the individual DIM bits is summarized in the table below.

DIM2	DIM1	DIM0	Characteristics
0		0	Transparent D-channel, the collision detection is disabled
0		1	Stop/go bit evaluated for D-channel access handling
0	0		Last octet of IOM channel 2 used for TIC bus access
0	1		TIC bus access is disabled
1	x	x	Reserved

4.1.8 EXMD1- Extended Mode Register D-channel 1

Value after reset: 00_H

	7					0		
EXMD1	XFBS	RFBS	SRA	XCRC	RCRC	0	ITF	RD/WR (23)

XFBS ... Transmit FIFO Block Size

0 ... Block size for the transmit FIFO data is 32 byte

1 ... Block size for the transmit FIFO data is 16 byte

Note: A change of XFBS will take effect after a receiver command (CMDRD.XME, CMDRD.XRES, CMDRD.XTF) has been written.

RFBS ... Receive FIFO Block Size

RFBS		Block Size Receive FIFO
Bit 6	Bit5	
0	0	32 byte
0	1	16 byte
1	0	8 byte
1	1	4 byte

Note: A change of RFBS will take effect after a transmitter command (CMDR.RMC, CMDR.RRES,) has been written

SRA ... Store Receive Address

0 ... Receive Address isn't stored in the RFIFOD

1 ... Receive Address is stored in the RFIFOD

XCRC ... Transmit CRC

0 ... CRC is transmitted

1 ... CRC isn't transmitted

RCRC... Receive CRC

0 ... CRC isn't stored in the RFIFOD

1 ... CRC is stored in the RFIFOD

Detailed Register Description

ITF... Interframe Time Fill

Selects the inter-frame time fill signal which is transmitted between HDLC-frames.

0 ... idle (continuous '1')

1 ... flags (sequence of patterns: '0111 1110')

Note: ITF must be set to '0' for power down mode.

In applications with D-channel access handling (collision resolution), the only possible inter-frame time fill is idle (continuous '1'). Otherwise the D-channel on the S/T-bus cannot be accessed

4.1.9 TIMR1 - Timer 1 Register

Value after reset: 00_H

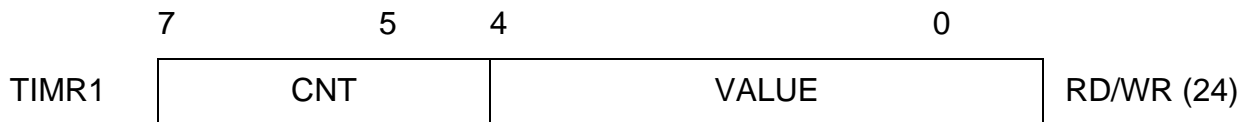

CNT ... Timer Counter

CNT together with VALUE determines the time period T after which a AUXI.TIN1 interrupt will be generated:

$$\text{CNT}=0\dots6: T = \text{CNT} \times 2.048 \text{ sec} + T1 \quad \text{with } T1 = (\text{VALUE}+1) \times 0.064 \text{ sec}$$

$$\text{CNT}=7: T = T1 = (\text{VALUE}+1) \times 0.064 \text{ sec} \quad (\text{generated periodically})$$

The timer can be started by setting the STI-bit in CMDRD and will be stopped when a TIN1 interrupt is generated or the TIMR1 register is written.

Note: If CNT is set to 7, a TIN interrupt is indefinitely generated after every expiration of T1 (i.e. T = T1).

VALUE ... Timer Value

Determines the value of the timer value **T1 = (VALUE + 1) x 0.064 sec.**

4.1.10 SAP1 - SAPI1 Register

Value after reset: FC_H

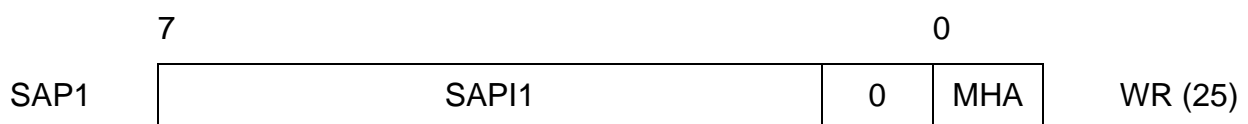

Detailed Register Description

SAPI1 ... SAPI1 value

Value of the first programmable Service Access Point Identifier (SAPI) according to the ISDN LAPD protocol.

MHA... Mask High Address

0 ...The SAPI address of an incoming frame is compared with SAP1, SAP2, SAPG.

1 ...The SAPI address of an incoming frame is compared with SAP1 and SAPG.

SAP1 can be masked with SAP2 thereby bit positions of SAP1 are not compared if they are set to '1' in SAP2.

4.1.11 SAP2 - SAPI2 Register

Value after reset: FC_H

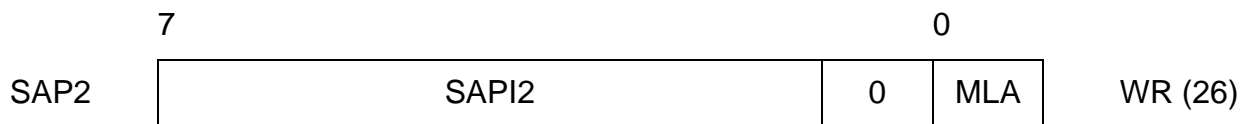

SAPI2 ... SAPI2 value

Value of the second programmable Service Access Point Identifier (SAPI) according to the ISDN LAPD-protocol.

MLA... Mask Low Address

0 ...The TEI address of an incoming frame is compared with TEI1, TEI2 and TEIG.

1 ...The TEI address of an incoming frame is compared with TEI1 and TEIG.

TEI1 can be masked with TEI2 thereby bit positions of TEI1 are not compared if they are set to '1' in TEI2.

4.1.12 RBCLD - Receive Frame Byte Count Low D-Channel

Value after reset: 00_H

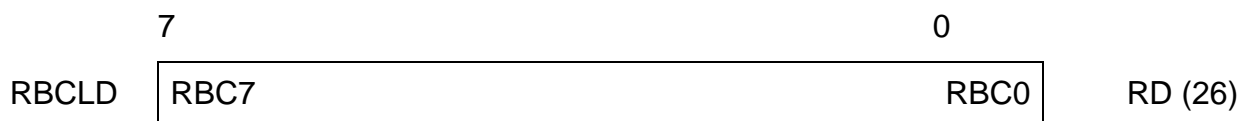

RBC7-0 ... Receive Byte Count

Eight least significant bits of the total number of bytes in a received message (see RBCHD register).

4.1.13 RBCHD - Receive Frame Byte Count High D-Channel

Value after reset: 00_H.

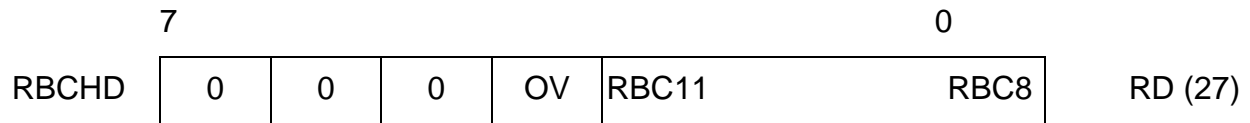

OV ... Overflow

A '1' in this bit position indicates a message longer than $(2^{12} - 1) = 4095$ bytes .

RBC8-11 ... Receive Byte Count

Four most significant bits of the total number of bytes in a received message (see RBCLD register).

Note: Normally RBCHD and RBCLD should be read by the microcontroller after an RME-interrupt in order to determine the number of bytes to be read from the RFIFOD, and the total message length. The contents of the registers are valid only after an RME or RPF interrupt, and remain so until the frame is acknowledged via the RMC bit or RRES.

4.1.14 TEI1 - TEI1 Register 1

Value after reset: FF_H

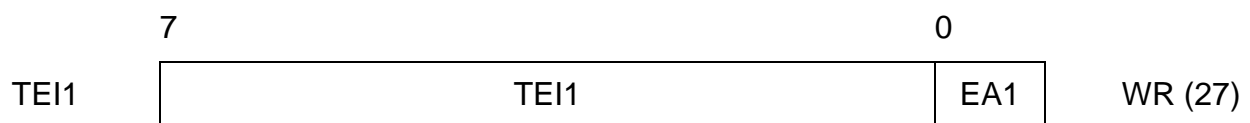

TEI1 ... Terminal Endpoint Identifier

In all message transfer modes except in transparent modes 0, 1 and extended transparent mode, TEI1 is used by the ISAC-SX TE for address recognition. In the case of a two-byte address field, it contains the value of the first programmable Terminal Endpoint Identifier according to the ISDN LAPD-protocol.

In non-automodes with one-byte address field, TEI1 is a command address, according to X.25 LAPB.

EA1 ... Address field Extension bit

This bit is set to '1' according to HDLC/LAPD.

4.1.15 TEI2 - TEI2 Register

Value after reset: FF_H

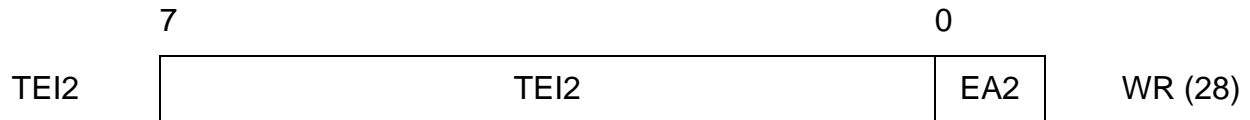

TEI2 ... Terminal Endpoint Identifier

In all message transfer modes except in transparent modes 0, 1 and extended transparent mode, TEI2 is used by the ISAC-SX TE for address recognition. In the case of a two-byte address field, it contains the value of the second programmable Terminal Endpoint Identifier according of the ISDN LAPD-protocol.

In non-auto-modes with one-byte address field, TEI2 is a response address, according to X.25 LAPD.

EA2 ... Address field Extension bit

This bit is to be set to '1' according to HDLC/LAPD.

4.1.16 RSTAD - Receive Status Register D-Channel

Value after reset: 0F_H

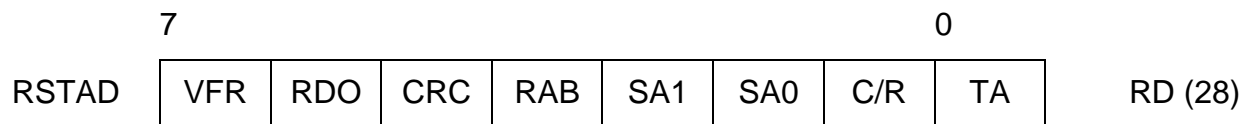

For general information please refer to [Chapter 3.8](#).

VFR... Valid Frame

Determines whether a valid frame has been received.

The frame is valid (1) or invalid (0).

A frame is invalid when there is not a multiple of 8 bits between flag and frame end (flag, abort).

RDO ... Receive Data Overflow

If RDO=1, at least one byte of the frame has been lost, because it could not be stored in RFIFOD. As opposed to the ISTAD.RFO an RDO indicates that the beginning of a frame has been received but not all bytes could be stored as the RFIFOD was temporarily full.

Detailed Register Description
CRC ... CRC Check

The CRC is correct (1) or incorrect (0).

RAB ... Receive Message Aborted

The receive message was aborted by the remote station (1), i.e. a sequence of seven 1's was detected before a closing flag.

SA1-0 ... SAPI Address Identification
TA ... TEI Address Identification

SA1-0 are significant in non-automode with a two-byte address field, as well as in transparent mode 3. TA is significant in all modes except in transparent modes 0 and 1. Two programmable SAPI values (SAP1, SAP2) plus a fixed group SAPI (SAPG of value FC_H/FE_H), and two programmable TEI values (TEI1, TEI2) plus a fixed group TEI (TEIG of value FF_H), are available for address comparison.

The result of the address comparison is given by SA1-0 and TA, as follows:

MDS2-0	SA1	SA0	TA	Address Match with	
				1 st Byte	2 nd Byte
010 (Non-Auto/8 Mode)	x	x	0	TEI2	-
	x	x	1	TEI1	-
011 (Non-Auto/16 Mode)	0	0	0	SAP2	TEIG
	0	0	1	SAP2	TEI2
	0	1	0	SAPG	TEIG
	0	1	1	SAPG	TEI1 or TEI2
	1	0	0	SAP1	TEIG
	1	0	1	SAP1	TEI1
111 (Transparent Mode1)	0	0	x	SAP2	-
	0	1	x	SAPG	-
	1	0	x	SAP1	-
101 (Transparent Mode 2)	-	-	0	-	TEIG
	-	-	1	-	TEI1 or TEI2
	1	1	x	reserved	

Note: If SAP1 and SAP2 contain identical values, the combination SAP1,2-TEIG will only be indicated by SA1,0 = '10' (i.e. the value '00' will not occur in this case).

C/R ... Command/Response

The C/R bit contains the C/R bit of the received frame (Bit1 in the SAPI address)

Note: The contents of RSTAD corresponds to the last received HDLC frame; it is duplicated into RFIFOD for every frame (last byte of frame)

4.1.17 TMD -Test Mode Register D-Channel

Value after reset: 00_H

	7							0	
TMD	0	0	0	0	0	0	0	TLP	RD/WR (29)

For general information please refer to [Chapter 3.9](#).

TLP ... Test Loop

The TX path of layer-2 is internally connected with the RX path of layer-2. Data coming from the layer 1 controller will not be forwarded to the layer 2 controller.

The setting of TLP is only valid if the IOM interface is active.

4.1.18 CIR0 - Command/Indication Receive 0

Value after reset: F3_H

	7					0		
CIR0	CODR0			CIC0	CIC1	S/G	BAS	RD (2E)

CODR0 ... C/I Code 0 Receive

Value of the received Command/Indication code. A C/I-code is loaded in CODR0 only after being the same in two consecutive IOM-frames and the previous code has been read from CIR0.

CIC0 ... C/I Code 0 Change

A change in the received Command/Indication code has been recognized. This bit is set only when a new code is detected in two consecutive IOM-frames. It is reset by a read of CIR0.

CIC1 ... C/I Code 1 Change

A change in the received Command/Indication code in IOM-channel 1 has been recognized. This bit is set when a new code is detected in one IOM-frame. It is reset by a read of CIR0.

S/G ... Stop/Go Bit Monitoring

Indicates the availability of the upstream D-channel on the S/T interface.

1: Stop

0: Go

BAS ... Bus Access Status

Indicates the state of the TIC-bus:

0: the ISAC-SX TE itself occupies the D- and C/I-channel

1: another device occupies the D- and C/I-channel

Note: The CODR0 bits are updated every time a new C/I-code is detected in two consecutive IOM-frames. If several consecutive valid new codes are detected and CIR0 is not read, only the first and the last C/I code is made available in CIR0 at the first and second read of that register, respectively.

4.1.19 CIX0 - Command/Indication Transmit 0

Value after reset: FE_H

	7					0	
CIX0	CODX0		TBA2	TBA1	TBA0	BAC	WR (2E)

CODX0 ... C/I-Code 0 Transmit

Code to be transmitted in the C/I-channel 0.

The code is only transmitted if the TIC bus is occupied. If TIC bus is enabled but occupied by another device, only "1s" are transmitted.

TBA2-0 ... TIC Bus Address

Defines the individual address for the ISAC-SX TE on the IOM bus.

This address is used to access the C/I- and D-channel on the IOM interface.

Note: If only one device is liable to transmit in the C/I- and D-channels of the IOM it should always be given the address value '7'.

BAC ... Bus Access Control

Only valid if the TIC-bus feature is enabled (MODED.DIM2-0).

If this bit is set, the ISAC-SX TE will try to access the TIC-bus to occupy the C/I-channel even if no D-channel frame has to be transmitted. It should be reset when the access has been completed to grant a similar access to other devices transmitting in that IOM-channel.

Note: Access is always granted by default to the ISAC-SX TE with TIC-Bus Address (TBA2-0, STCR register) '7', which has the lowest priority in a bus configuration.

4.1.20 CIR1 - Command/Indication Receive 1

Value after reset: FE_H

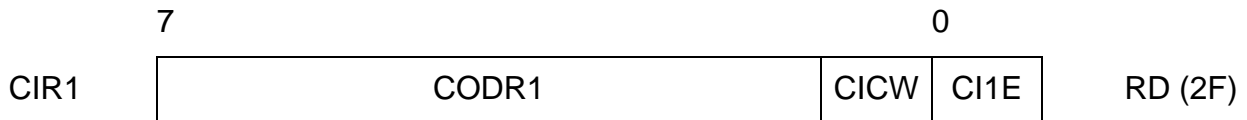

CODR1 ... C/I-Code 1 Receive

CICW, CI1E ... C/I-Channel Width, C/I-Channel 1 Interrupt Enable

These two bits contain the read back values from CIX1 register (see below).

4.1.21 CIX1 - Command/Indication Transmit 1

Value after reset: FE_H

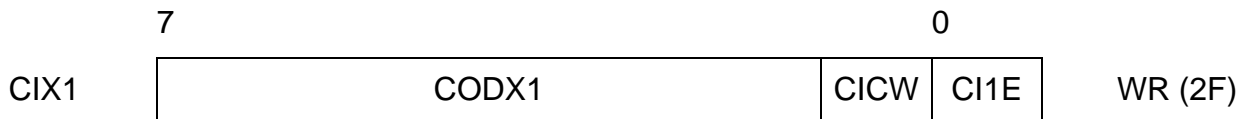

CODX1 ... C/I-Code 1 Transmit

Bits 7-2 of C/I-channel 1.

CICW... C/I-Channel Width

CICW selects between a 4 bit ('0') and 6 bit ('1') C/I1 channel width.

The C/I1 handler always reads and writes 6-bit values but if 4-bit is selected, the higher two bits are ignored for interrupt generation. However in write direction the full CODX1 code is transmitted, i.e. the host must write the higher two bits to "1".

CI1E ... C/I-Channel 1 Interrupt Enable

Interrupt generation ISTA.CIC of CIR0.CIC1 is enabled (1) or masked (0).

4.2 Transceiver Registers

4.2.1 TR_CONF0 - Transceiver Configuration Register 0

Value after reset: 01_H

	7							0	
TR_CONF0	DIS_TR	0	EN_ICV	0	0	0	EXLP	LDD	RD/WR (30)

DIS_TR ... Disable Transceiver

Setting DIS_TR to “1” disables the transceiver. In order to reenale the transceiver again, a transceiver reset must be issued (SRES.RES_TR = 1). The transceiver must not be reenaled by setting DIS_TR from “1” to “0”.

For general information please refer to [Chapter 3.3.9](#).

EN_ICV ... Enable Illegal Code Violation

0: normal operation

1: ICV enabled. The receipt of at least one illegal code violation within one multi-frame is indicated by the C/I indication '1011' (CVR) in two consecutive IOM frames.

EXLP ... External loop

In case the analog loopback is activated with C/I = ARL the loop is a

0: internal loop next to the line pins

1: external loop which has to be closed between SR1/2 and SX1/SX2

Note: The external loop is only useful if bit DIS_TX of register TR_CONF2 is set to '0'.

For general information please refer to [Chapter 3.3.10](#).

LDD ... Level Detection Discard

0: Automatic clock generation after detection of any signal on the line in power down state

1: No clock generation after detection of any signal on the line in power down state

Note: If an interrupt by the level detect circuitry is generated, the microcontroller has to set this bit to '0' for an activation of the S/T interface.

For general information please refer to [Chapter 3.3.8](#) and [Chapter 3.7.6](#).

4.2.2 TR_CONF1 - Transceiver Configuration Register 1

Value after reset: 0x_H

	7						0		
TR_CONF1	0	RPLL_ADJ	EN_SFSC	0	0	x	x	x	RD/WR (31)

RPLL_ADJ ... Receive PLL Adjustment

0: DPLL tracking step is 0.5 XTAL period per S-frame

1: DPLL tracking step is 1 XTAL period per S-frame

EN_SFSC ... Enable Short FSC

0: No short FSC is generated

1: A short FSC is generated once per multi-frame (every 40th IOM frame)

x ... Undefined

The value of these bits depends on the selected mode. It is important to note that these bits must not be overwritten to a different value when accessing this register.

4.2.3 TR_CONF2 - Transmitter Configuration Register 2

Value after reset: 80_H

	7						0		
TR_CONF2	DIS_TX	PDS	0	RLP	0	0	0	0	RD/WR (32)

DIS_TX ... Disable Line Driver

0: Transmitter is enabled

1: Transmitter is disabled

For general information please refer to [Chapter 3.3.9](#).

PDS ... Phase Deviation Select

Defines the phase deviation of the S-transmitter.

0: The phase deviation is 2 S-bits minus 7 oscillator periods plus analog delay plus delay of the external circuitry.

Detailed Register Description

1: The phase deviation is 2 S-bits minus 9 oscillator periods plus analog delay plus delay of the external circuitry.

For general information please refer to [Chapter 3.3.7](#).

RLP ... Remote Line Loop

0: Remote Line Loop open

1: Remote Line Loop closed

For general information please refer to [Chapter 3.3.10](#).

4.2.4 TR_STA - Transceiver Status Register

Value after reset: 00_H

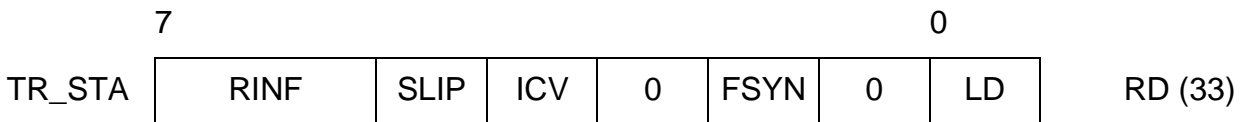

RINF ... Receiver INFO

00: Received INFO 0

01: Received any signal except INFO 0,2,4

10: Reserved INFO 2

11: Received INFO 4

SLIP ... SLIP Detected

A '1' in this bit position indicates that a SLIP is detected in the receive or transmit path.

ICV ... Illegal Code Violation

0: No illegal code violation is detected

1: Illegal code violation (ANSI T1.605) in data stream is detected

FSYN ... Frame Synchronization State

0: The S/T receiver is not synchronized

1: The S/T receiver has synchronized to the framing bit F

LD ... Level Detection

0: No receive signal has been detected on the line.

1: Any receive signal has been detected on the line.

4.2.5 SQRR1 - S/Q-Channel Receive Register 1

Value after reset: 40_H

	7						0		
SQRR	MSYN	MFEN	0	0	SQR1	SQR2	SQR3	SQR4	RD (35)

For general information please refer to [Chapter 3.3.2](#).

MSYN ... Multi-frame Synchronization State

0: The S/T receiver has not synchronized to the received F_A and M bits

1: The S/T receiver has synchronized to the received F_A and M bits

MFEN ... Multiframe Enable

Read-back of the MFEN bit of the SQXR register

SQR11-14 ... Received S Bits

Received S bits in frames 1, 6, 11 and 16

4.2.6 SQXR1- S/Q-Channel TX Register 1

Value after reset: 4F_H

	7						0		
SQXR1	0	MFEN	0	0	SQX1	SQX2	SQX3	SQX4	WR (35)

MFEN ... Multiframe Enable

Used to enable or disable the multiframe structure (see [Chapter 3.3.2](#))

0: S/T multiframe is disabled

1: S/T multiframe is enabled

Readback value in SQRR1.

SQX1-4 ... Transmitted S/Q Bits

Transmitted Q bits (F_A bit position) in frames 1, 6, 11 and 16.

4.2.7 SQR2 - S/Q-Channel Receive Register 2

Value after reset: 00_H

	7							0	
SQR2	SQR21	SQR22	SQR23	SQR24	SQR31	SQR32	SQR33	SQR34	RD (36)

SQR21-24, SQR31-34... Received S Bits

Received S bits in frames 2, 7, 12 and 17 (SQR21-24, subchannel 2), and in frames 3, 8, 13 and 18 (SQR31-34, subchannel 3).

4.2.8 SQR3 - S/Q-Channel Receive Register 3

Value after reset: 00_H

	7							0	
SQR3	SQR41	SQR42	SQR43	SQR44	SQR51	SQR52	SQR53	SQR54	RD (37)

SQR41-44, SQR51-54... Received S Bits

Received S bits in frames 4, 9, 14 and 19 (SQR41-44, subchannel 4), and in frames 5, 10, 15 and 20 (SQR51-54, subchannel 5).

4.2.9 ISTATR - Interrupt Status Register Transceiver

Value after reset: 00_H

	7							0	
ISTATR	x	x	x	x	LD	RIC	SQC	SQW	RD (38)

For all interrupts in the ISTATR register the following logical states are defined:

- 0: Interrupt is not activated
- 1: Interrupt is activated

x ... Reserved

Bits set to "1" in this bit position must be ignored.

LD ... Level Detection

Any receive signal has been detected on the line. This bit is set to “1” (i.e. an interrupt is generated if not masked) as long as any receiver signal is detected on the line.

RIC ... Receiver INFO Change

RIC is activated if one of the TR_STA bits RINF or ICV has changed. This bit is reset by reading the TR_STA register.

SQC ... S/Q-Channel Change

A change in the received S-channel has been detected. The new code can be read from the SQRxx bits of registers SQRR1-3 within the duration of the next multiframe (5 ms). This bit is reset by a read access to the corresponding SQRRx register.

SQW ... S/Q-Channel Writable

The S/Q channel data for the next multiframe is writable. The register for the Q (S) bits to be transmitted (received) has to be written (read) within the duration of the next multiframe (5 ms). This bit is reset by writing register SQXRx.

4.2.10 MASKTR - Mask Transceiver Interrupt

Value after reset: FF_H

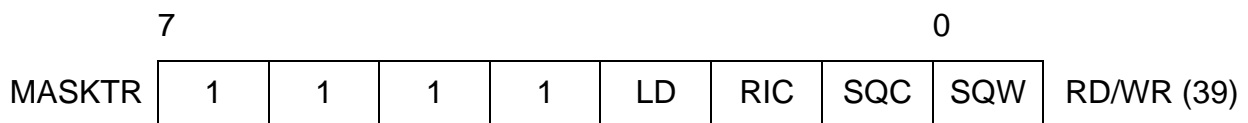

The transceiver interrupts LD, RIC, SQC and SQW are enabled (0) or disabled (1).

4.2.11 ACFG2 - Auxiliary Configuration Register

Value after reset: 00_H

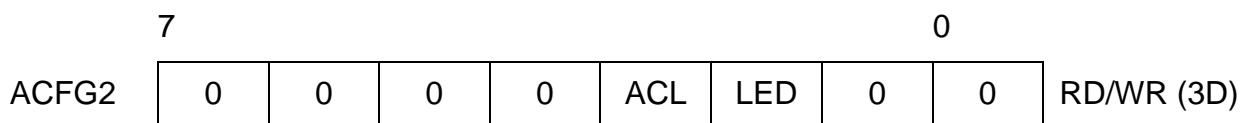

Note: Although no other Auxiliary Configuration Registers are supported by ISAC-SX TE, the name ACFG2 for this register was chosen intentionally in compliance with ISAC-SX PEB3086.

Detailed Register Description**ACL ... $\overline{\text{ACL}}$ Function Select**

0: Pin $\overline{\text{ACL}}$ automatically indicates the S-bus activation status by a LOW level.

1: The output state of $\overline{\text{ACL}}$ is programmable by the host in bit LED.

Note: An LED with preresistance may directly be connected to $\overline{\text{ACL}}$.

LED ... LED Control

If enabled (ACL = 1) the LED with preresistance connected across VDD and $\overline{\text{ACL}}$ is switched ...

0: ... OFF (high level on pin $\overline{\text{ACL}}$)

1: ... ON (low level on pin $\overline{\text{ACL}}$)

Detailed Register Description

4.3 IOM-2 and MONITOR Handler

4.3.1 CDAxy - Controller Data Access Register xy

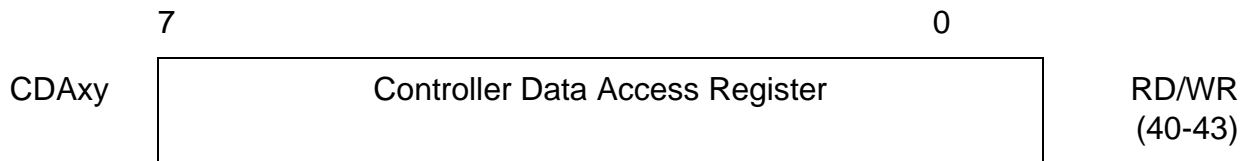

Data registers CDAxy which can be accessed from the controller.

Register	Register Address	Value after Reset
CDA10	40 _H	FF _H
CDA11	41 _H	FF _H
CDA20	42 _H	FF _H
CDA21	43 _H	FF _H

4.3.2 XXX_TSDPxy - Time Slot and Data Port Selection for CHxy

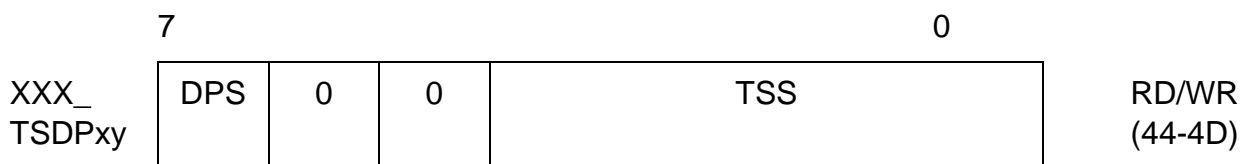

Register	Register Address	Value after Reset
CDA_TSDP10	44 _H	00 _H (= output on B1-DD)
CDA_TSDP11	45 _H	01 _H (= output on B2-DD)
CDA_TSDP20	46 _H	80 _H (= output on B1-DU)
CDA_TSDP21	47 _H	81 _H (= output on B2-DU)
TR_TSDP_BC1	4C _H	00 _H (= transceiver output on B1-DD)
TR_TSDP_BC2	4D _H	01 _H (= transceiver output on B2-DD)

This register determines the time slots and the data ports on the IOM-2 interface for the data channels 'xy' of the functional units 'XXX' which are Controller Data Access (CDA) and Transceiver (TR).

Detailed Register Description

The position of B-channel data from the S-interface is programmed in TR_TSDP_BC1 and TR_TSDP_BC2.

DPS ... Data Port Selection

- 0: The data channel xy of the functional unit XXX is output on DD.
The data channel xy of the functional unit XXX is input from DU.
- 1: The data channel xy of the functional unit XXX is output on DU.
The data channel xy of the functional unit XXX is input from DD.

Note: For the CDA (controller data access) data the input is determined by the CDA_CRx.SWAP bit. If SWAP = '0' the input for the CDAxy data is vice versa to the output setting for CDAxy. If the SWAP = '1' the input from CDAx0 is vice versa to the output setting of CDAx1 and the input from CDAx1 is vice versa to the output setting of CDAx0. See controller data access description in [Chapter 3.7.1.1](#)

TSS ... Timeslot Selection

Selects one of 32 timeslots (0...31) on the IOM-2 interface for the data channels.

4.3.3 CDAx_CR - Control Register Controller Data Access CH1x

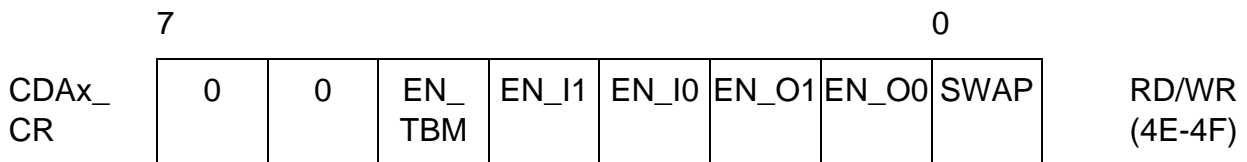

Register	Register Address	Value after Reset
CDA1_CR	4E _H	00 _H
CDA2_CR	4F _H	00 _H

For general information please refer to [Chapter 3.7.1.1](#).

EN_TBM ... Enable TIC Bus Monitoring

- 0: The TIC bus monitoring is disabled
- 1: The TIC bus monitoring with the CDAx0 register is enabled. The TSDPx0 register must be set to 08_H for monitoring from DU or 88_H for monitoring from DD, respectively (this selection is only valid if IOM_CR.TIC_DIS = 0).

EN_I1, EN_I0 ... Enable Input CDAX0, CDAX1

- 0: The input of the CDAX0, CDAX1 register is disabled
- 1: The input of the CDAX0, CDAX1 register is enabled

EN_O1, EN_O0 ... Enable Output CDAX0, CDAX1

- 0: The output of the CDAX0, CDAX1 register is disabled
- 1: The output of the CDAX0, CDAX1 register is enabled

SWAP ... Swap Inputs

- 0: The time slot and data port for the input of the CDAXy register is defined by its own TSDPxxy register. The data port for the CDAXy input is vice versa to the output setting for CDAXy.
- 1: The input (time slot and data port) of the CDAX0 is defined by the TSDP register of CDAX1 and the input of CDAX1 is defined by the TSDP register of CDAX0. The data port for the CDAX0 input is vice versa to the output setting for CDAX1. The data port for the CDAX1 input is vice versa to the output setting for CDAX0. The input definition for time slot and data port CDAX0 are thus swapped to CDAX1 and for CDAX1 to CDAX0. The outputs are not affected by the SWAP bit.

4.3.4 TR_CR - Control Register Transceiver Data (IOM_CR.CI_CS=0)

Value after reset: F8_H

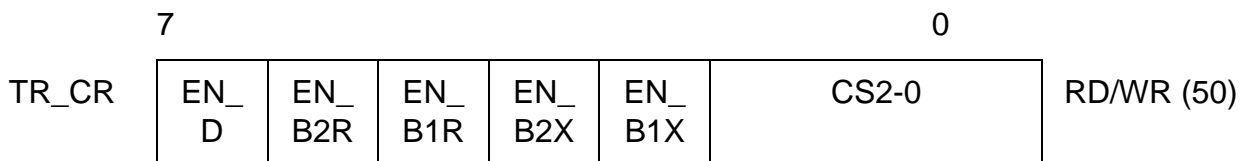

Read and write access to this register is only possible if IOM_CR.CI_CS = 0.

- EN_D ... Enable Transceiver D-Channel Data**
- EN_B2R ... Enable Transceiver B2 Receive Data**
- EN_B1R ... Enable Transceiver B1 Receive Data**
- EN_B2X ... Enable Transceiver B2 Transmit Data**
- EN_B1X ... Enable Transceiver B1 Transmit Data**

This register is used to individually enable/disable the D-channel (both RX and TX direction) and the receive/transmit paths for the B-channel of the S-transceiver.

- 0: The corresponding data path to the transceiver is disabled.
- 1: The corresponding data path to the transceiver is enabled.

Detailed Register Description

CS2-0 ... Channel Select for Transceiver D-channel

This register is used to select one of eight IOM channels to which the transceiver D-channel data is related to.

Note: It should be noted that writing TR_CR.CS2-0 will also write to TRC_CR.CS2-0 and therefore modify the channel selection for the transceiver C/I/O data.

4.3.4.1 TRC_CR - Control Register Transceiver C/I/O (IOM_CR.CI_CS=1)

Value after reset: 00_H

	7					0	
TRC_CR	0	0	0	0	0	CS2-0	RD/WR (50)

Write access to this register is possible if IOM_CR.CI_CS = 0 or IOM_CR.CI_CS = 1.
Read access to this register is possible only if IOM_CR.CI_CS = 1.

CS2-0 ... Channel Select for the Transceiver C/I/O Channel

This register is used to select one of eight IOM channels to which the transceiver C/I/O channel data is related to.

4.3.5 DCI_CR - Control Register for D and CI1 Handler (IOM_CR.CI_CS=0)

Value after reset: A0_H

	7					0	
DCI_CR	DPS_ CI1	EN_ CI1	D_ EN_D	D_ EN_B2	D_ EN_B1	CS2-0	RD/WR (53)

Read and write access to this register is only possible if IOM_CR.CI_CS = 0.

DPS_CI1 ... Data Port Selection CI1 Handler Data

0: The CI1 handler data is output on DD and input from DU

1: The CI1 handler data is output on DU and input from DD

EN_CI1 ... Enable CI1 Handler Data

0: CI1 handler data access is disabled

1: CI1 handler data access is enabled

Detailed Register Description

Note: The timeslot for the C/I1 handler cannot be programmed but is fixed to IOM channel 1.

D_EN_D ... Enable D-timeslot for D-channel controller

D_EN_B2 ... Enable B2-timeslot for D-channel controller

D_EN_B1 ... Enable B1-timeslot for D-channel controller

These bits are used to select the timeslot length for the D-channel HDLC controller access as it is capable to access not only the D-channel timeslot. The host can individually enable two 8-bit timeslots B1- and B2-channel (D_EN_B1, D_EN_B2) and one 2-bit timeslot D-channel (D_EN_D) on IOM-2. The position is selected via CS2-0.

0: D-channel controller does not access timeslot data B1, B2 or D, respectively

1: D-channel controller does access timeslot data B1, B2 or D, respectively

CS2-0 ... Channel Select for D-channel controller

This register is used to select one of eight IOM channels. If enabled, the D-channel data is connected to the corresponding timeslots of that IOM channel.

Note: It should be noted that writing DCI_CR.CS2-0 will also write to DCIC_CR.CS2-0 and therefore modify the channel selection for the data of the C/I0 handler.

4.3.5.1 DCIC_CR - Control Register for C/I0 Handler (IOM_CR.CI_CS=1)

Value after reset: 00_H

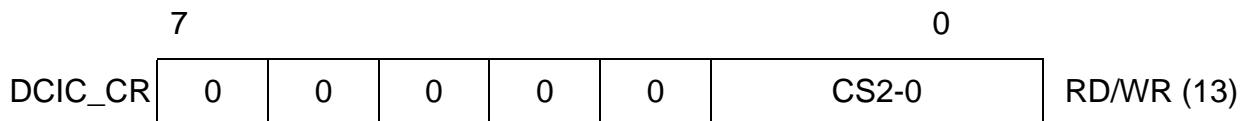

Write access to this register is possible if IOM_CR.CI_CS = 0 or IOM_CR.CI_CS = 1.

Read access to this register is possible only if IOM_CR.CI_CS = 1.

CS2-0 ... Channel Select for C/I0 Handler

This register is used to select one of eight IOM channels. If enabled, the data of the C/I0-handler is connected to the corresponding C/I0 timeslots of that IOM channel.

4.3.6 MON_CR - Control Register Monitor Data

Value after reset: 40_H

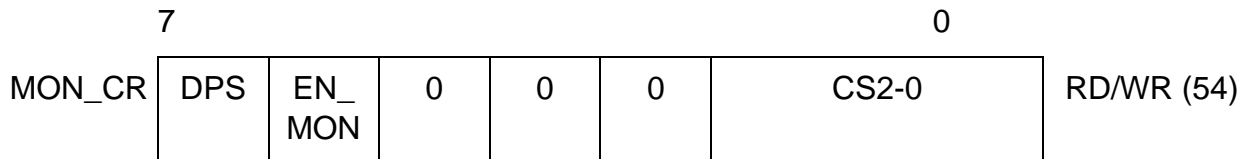

For general information please refer to [Chapter 3.7.3](#).

DPS ... Data Port Selection

0: The Monitor data is output on DD and input from DU

1: The Monitor data is output on DU and input from DD

EN_MON ... Enable Output

0: The Monitor data input and output is disabled

1: The Monitor data input and output is enabled

CS2-0 ... MONITOR Channel Selection

000: The MONITOR data is input/output on MON0 (3rd timeslot on IOM-2)

001: The MONITOR data is input/output on MON1 (7th timeslot on IOM-2)

010: The MONITOR data is input/output on MON2 (11th timeslot on IOM-2)

:

111: The MONITOR data is input/output on MON7 (31st timeslot on IOM-2)

4.3.7 SDS_CR - Control Register Serial Data Strobe

Value after reset: 00_H

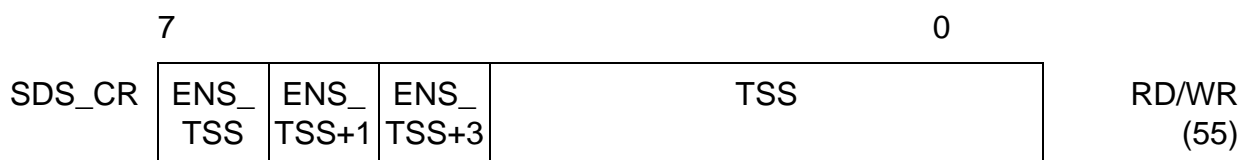

This register is used to select position and length of the strobe signal. The length can be any combination of two 8-bit timeslot (ENS_TSS, ENS_TSS+1) and one 2-bit timeslot (ENS_TSS+3).

For general information please refer to [Chapter 3.7.2](#) and [Chapter 3.7.2.2](#).

ENS_TSS ... Enable Serial Data Strobe of timeslot TSS

ENS_TSS+1 ... Enable Serial Data Strobe of timeslot TSS+1

0: The serial data strobe signal SDSx is inactive during TSS, TSS+1

1: The serial data strobe signal SDSx is active during TSS, TSS+1

ENS_TSS+3 ... Enable Serial Data Strobe of timeslot TSS+3 (D-Channel)

0: The serial data strobe signal SDSx is inactive during the D-channel (bit7, 6) of TSS+3

1: The serial data strobe signal SDSx is active during the D-channel (bit7, 6) of TSS+3

TSS ... Timeslot Selection

Selects one of 32 timeslots on the IOM-2 interface (with respect to FSC) during which SDSx is active high or provides a strobed BCL clock output (see SDS_CONF.SDS_BCL). The data strobe signal allows standard data devices to access a programmable channel.

4.3.8 IOM_CR - Control Register IOM Data

Value after reset: 08_H

	7							0	
IOM_CR	SPU	0	CI_CS	TIC_ DIS	EN_ BCL	CLKM	DIS_ OD	DIS_ IOM	RD/WR (57)

SPU ... Software Power Up

0: The DU line is normally used for transmitting data

1: Setting this bit to '1' will pull the DU line to low. This will enforce connected layer 1 devices to deliver IOM-clocking.

After a subsequent ISTA.CIC-interrupt (C/I-code change) and reception of the C/I-code "PU" (Power Up indication in TE-mode) the microcontroller writes an AR or TIM command as C/I-code in the CIX0-register, resets the SPU bit and waits for the following CIC-interrupt.

For general information please refer to [Chapter 3.7.6](#).

CI_CS ... C/I Channel Selection

The channel selection for D-channel and C/I-channel is done in the channel select bits CH2-0 of register TR_CR (for the transceiver) and DCI_CR (for the D-channel controller and C/I-channel controller).

Detailed Register Description

0: A write access to CS2-0 has effect on the configuration of D- and C/I-channel, whereas a read access delivers the D-channel configuration only.

1: A write access to CS2-0 has effect on the configuration of the C/I-channel only, whereas a read access delivers the C/I-channel configuration only.

TIC_DIS ... TIC Bus Disable

0: The last octet of IOM channel 2 (12th timeslot) is used as TIC bus.

1: The TIC bus is disabled. The last octet of the last IOM time slot (TS 11) can be used as every time slot.

EN_BCL ... Enable Bit Clock BCL

0: The BCL clock is disabled

1: The BCL clock is enabled.

CLKM ... Clock Mode

If the transceiver is disabled (DIS_TR = '1') the DCL from the IOM-2 interface is an input.

0: A double bit clock is connected to DCL

1: A single bit clock is connected to DCL

For general information please refer to [Chapter 3.7](#).

DIS_OD ... Disable Open Drain Drivers

0: DU/DD are open drain drivers

1: DU/DD are push pull drivers

DIS_IOM ... Disable IOM

DIS_IOM should be set to '1' if external devices connected to the IOM interface should be "disconnected" e.g. for power saving purposes or for not disturbing the internal IOM connection between layer 1 and layer 2. However, the ISAC-SX TE internal operation between S-transceiver, B-channel and D-channel controller is independent of the DIS_IOM bit.

0: The IOM interface is enabled

1: The IOM interface is disabled. The FSC, DCL clock outputs have high impedance; clock inputs are active; DU, DD data line inputs are switched off and outputs have high impedance; except in TE/LT-T mode the DU line is input ("0"-level causes activation), so the DU pin must be terminated (pull up resistor).

4.3.9 STI - Synchronous Transfer Interrupt

Value after reset: 00_H

	7						0		
STI	STOV 21	STOV 20	STOV 11	STOV 10	STI 21	STI 20	STI 11	STI 10	RD (58)

For all interrupts in the STI register the following logical states are applied:

0: Interrupt is not activated

1: Interrupt is activated

The interrupts are automatically reset by reading the STI register. For general information please refer to [Chapter 3.7.1.1](#).

STOVxy ... Synchronous Transfer Overflow Interrupt

Enabled STOV interrupts for a certain STI_{xy} interrupt are generated when the STI_{xy} has not been acknowledged in time via the ACK_{xy} bit in the ASTI register. This must be one (for DPS='0') or zero (for DPS='1') BCL clocks before the time slot which is selected for the STOV.

STI_{xy} ... Synchronous Transfer Interrupt

Depending on the DPS bit in the corresponding TSDP_{xy} register the Synchronous Transfer Interrupt STI_{xy} is generated two (for DPS='0') or one (for DPS='1') BCL clock after the selected time slot (TSDP_{xy}.TSS).

Note: STOV_{xy} and ACK_{xy} are useful for synchronizing microcontroller accesses and receive/transmit operations. One BCL clock is equivalent to two DCL clock cycles.

4.3.10 ASTI - Acknowledge Synchronous Transfer Interrupt

Value after reset: 00_H

	7						0		
ASTI	0	0	0	0	ACK 21	ACK 20	ACK 11	ACK 10	WR (58)

For general information please refer to [Chapter 3.7.1.1](#).

ACKxy ... Acknowledge Synchronous Transfer Interrupt

After an STIxy interrupt the microcontroller has to acknowledge the interrupt by setting the corresponding ACKxy bit to “1”.

4.3.11 MSTI - Mask Synchronous Transfer Interrupt

Value after reset: FF_H

	7				0				
MSTI	STOV 21	STOV 20	STOV 11	STOV 10	STI 21	STI 20	STI 11	STI 10	RD/WR (59)

For the MSTI register the following logical states are applied:

0: Interrupt is not masked

1: Interrupt is masked

For general information please refer to [Chapter 3.7.1.1](#).

STOVxy ... Synchronous Transfer Overflow for STIxy

Mask bits for the corresponding STOVxy interrupt bits.

STIxy ... Synchronous Transfer Interrupt xy

Mask bits for the corresponding STIxy interrupt bits.

4.3.12 SDS_CONF - Configuration Register for Serial Data Strobe

Value after reset: 00_H

	7				0				
SDS_CONF	0	0	0	0	DIOM_ INV	DIOM_ SDS	0	SDS_ BCL	RD/WR (5A)

For general information on SDS_BCL please refer to [Chapter 3.7.2](#).

DIOM_INV ... DU/DD on IOM Timeslot Inverted

0: DU/DD are active during SDS HIGH phase and inactive during the LOW phase.

1: DU/DD are active during SDS LOW phase and inactive during the HIGH phase.

This bit has only effect if DIOM_SDS is set to '1' otherwise DIOM_INV is don't care.

Detailed Register Description

DIOM_SDS ... DU/DD on IOM Controlled via SDS

0: The pin SDS and its configuration settings are used for serial data strobe only. The IOM-2 data lines are not affected.

1: The DU/DD lines are deactivated during the during High/Low phase (selected via DIOM_INV) of the SDS signal. The SDS timeslot is selected in SDS_CR.

SDS_BCL ... Enable IOM Bit Clock for SDS

0: The serial data strobe is generated in the programmed timeslot.

1: The IOM bit clock is generated in the programmed timeslot.

4.3.13 MCDA - Monitoring CDA Bits

Value after reset: FF_H

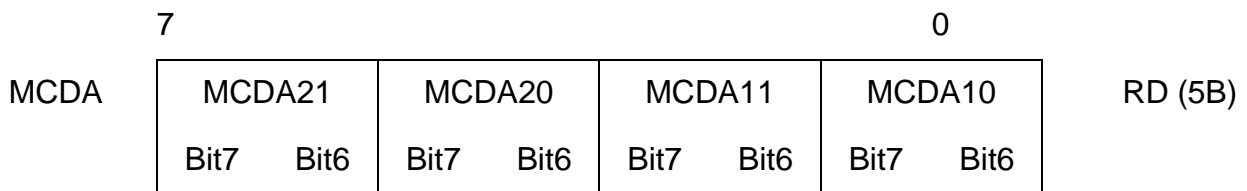

MCDAxy ... Monitoring CDAxy Bits

Bit 7 and Bit 6 of the CDAxy registers are mapped into the MCDA register.

This can be used for monitoring the D-channel bits on DU and DD and the 'Echo bits' on the TIC bus with the same register

4.3.14 MOR - MONITOR Receive Channel

Value after reset: FF_H

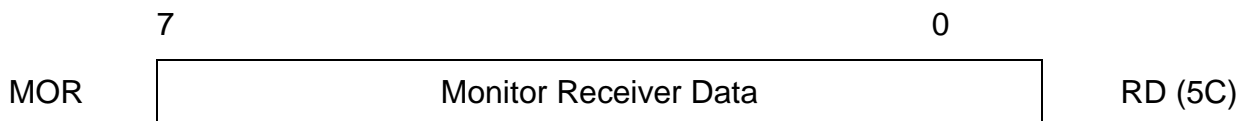

Contains the MONITOR data received in the IOM-2 MONITOR channel according to the MONITOR channel protocol. The MONITOR channel (0-7) can be selected by setting the monitor channel select bit MON_CR.MCS.

4.3.15 MOX - MONITOR Transmit Channel

Value after reset: FF_H

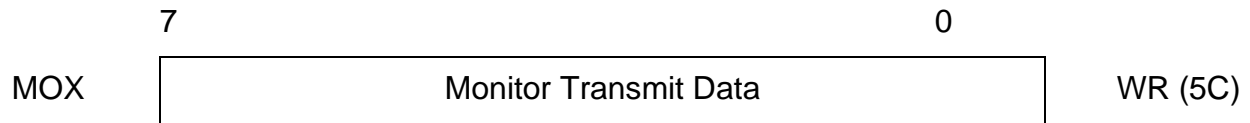

Contains the MONITOR data to be transmitted in IOM-2 MONITOR channel according to the MONITOR channel protocol. The MONITOR channel (0-7) can be selected by setting the monitor channel select bit MON_CR.MCS

4.3.16 MOSR - MONITOR Interrupt Status Register

Value after reset: 00_H

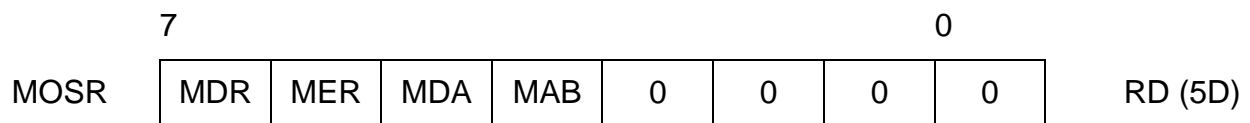

MDR ... MONITOR channel Data Received

MER ... MONITOR channel End of Reception

MDA ... MONITOR channel Data Acknowledged

The remote end has acknowledged the MONITOR byte being transmitted.

MAB ... MONITOR channel Data Abort

4.3.17 MOCR - MONITOR Control Register

Value after reset: 00_H

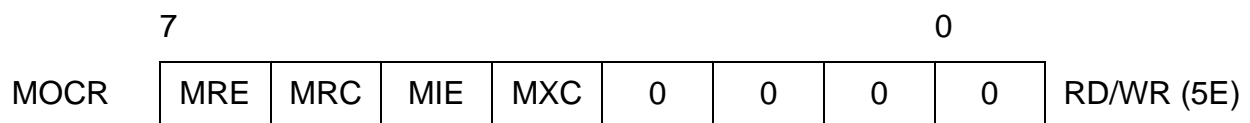

MRE ... MONITOR Receive Interrupt Enable

0: MONITOR interrupt status MDR generation is masked

1: MONITOR interrupt status MDR generation is enabled

MRC ... MR Bit Control

Determines the value of the MR bit:

- 0: MR is always '1'. In addition, the MDR interrupt is blocked, except for the first byte of a packet (if MRE = 1).
- 1: MR is internally controlled by the ISAC-SX TE according to MONITOR channel protocol.
In addition, the MDR interrupt is enabled for all received bytes according to the MONITOR channel protocol (if MRE = 1).

MIE ... MONITOR Interrupt Enable

MONITOR interrupt status MER, MDA, MAB generation is enabled (1) or masked (0).

MXC ... MX Bit Control

Determines the value of the MX bit:

- 0: The MX bit is always '1'.
- 1: The MX bit is internally controlled by the ISAC-SX TE according to MONITOR channel protocol.

4.3.18 MSTA - MONITOR Status Register

Value after reset: 00_H

MSTA	0	0	0	0	0	MAC	0	TOUT	RD (5F)
------	---	---	---	---	---	-----	---	------	---------

MAC ... MONITOR Transmit Channel Active

The data transmission in the MONITOR channel is in progress.

TOUT ... Time-Out

Read-back value of the TOUT bit.

4.3.19 MCONF - MONITOR Configuration Register

Value after reset: 00_H

MCONF	0	0	0	0	0	0	0	TOUT	WR (5F)
-------	---	---	---	---	---	---	---	------	---------

TOUT... Time-Out

0: The monitor time-out function is disabled

1: The monitor time-out function is enabled

4.4 Interrupt and General Configuration

4.4.1 ISTA - Interrupt Status Register

Value after reset: 00_H

	7							0	
ISTA	0	0	ST	CIC	AUX	TRAN	MOS	ICD	RD (60)

For all interrupts in the ISTA register following logical states are applied:

0: Interrupt is not activated

1: Interrupt is activated

ICD ... HDLC Interrupt from D-channel

An interrupt originated from the HDLC controller of the D-channel has been recognized.

ST ... Synchronous Transfer

This interrupt is generated to enable the microcontroller to lock on to the IOM timing for synchronous transfers. The source can be read from the STI register.

CIC ... C/I Channel Change

A change in C/I channel 0 or C/I channel 1 has been recognized. The actual value can be read from CIR0 or CIR1.

AUX ... Auxiliary Interrupts

Signals an interrupt generated from external awake (pin \overline{EAW}), watchdog timer overflow, timer1 or timer2. The source can be read from the auxiliary interrupt register AUXI.

TRAN ... Transceiver Interrupt

An interrupt originated in the transceiver interrupt status register (ISTATR) has been recognized.

MOS ... MONITOR Status

A change in the MONITOR Status Register (MOSR) has occurred.

Note: A read of the ISTA register clears none of the interrupts. They are only cleared by reading the corresponding status register.

4.4.2 MASK - Mask Register

Value after reset: FF_H

	7						0		
MASK	1	1	ST	CIC	AUX	TRAN	MOS	ICD	WR (60)

For the MASK register following logical states are applied:

- 0: Interrupt is enabled
- 1: Interrupt is disabled

Each interrupt source in the ISTA register can selectively be masked/disabled by setting the corresponding bit in MASK to '1'. Masked interrupt status bits are not indicated when ISTA is read. Instead, they remain internally stored and pending, until the mask bit is reset to '0'.

Note: In the event of a C/I channel change, CIC is set in ISTA even if the corresponding mask bit in MASK is set, but no interrupt is generated.

4.4.3 AUXI - Auxiliary Interrupt Status Register

Value after reset: 00_H

	7						0		
AUXI	0	0	EAW	WOV	TIN2	TIN1	0	0	RD (61)

For all interrupts in the ISTA register the following logical states are applied:

- 0: Interrupt is not acitvated
- 1: Interrupt is acitvated

EAW ... External Awake Interrupt

An interrupt from the $\overline{\text{EAW}}$ pin has been detected.

WOV ... Watchdog Timer Overflow

Signals the expiration of the watchdog timer, which means that the microcontroller has failed to set the watchdog timer control bits WTC1 and WTC2 (MODE1 register) in the correct manner. A reset pulse has been generated by the ISAC-SX TE.

TIN2, 1 ... Timer Interrupt 1, 2

An interrupt originated from timer 1 or timer 2 is recognized, i.e the timer has expired.

4.4.4 AUXM - Auxiliary Mask Register

Value after reset: FF_H

	7						0		
AUXM	1	1	EAW	WOV	TIN2	TIN1	1	1	WR (61)

For the MASK register following logical states are applied:

- 0: Interrupt is enabled
- 1: Interrupt is disabled

Each interrupt source in the AUXI register can selectively be masked/disabled by setting the corresponding bit in AUXM to '1'. Masked interrupt status bits are not indicated when AUXI is read. Instead, they remain internally stored and pending, until the mask bit is reset to '0'.

4.4.5 MODE1 - Mode1 Register

Value after reset: 00_H

	7						0		
MODE1	0	0	0	WTC1	WTC2	CFS	RSS2	RSS1	RD/WR (62)

WTC1, 2 ... Watchdog Timer Control 1, 2

After the watchdog timer mode has been selected (RSS = '11') the watchdog timer is started. During every time period of 128 ms the microcontroller has to program the WTC1 and WTC2 bit in the following sequence

	WTC1	WTC2
1.	1	0
2.	0	1

to reset and restart the watchdog timer.

If WTC1/2 is not written fast enough in this way, the timer expires and a WOV-interrupt (AUXI register) together with a reset pulse is generated.

CFS ... Configuration Select

This bit determines clock relations and recovery on S/T and IOM interfaces.

Detailed Register Description

0: The IOM interface clock and frame signals are always active, "Power Down" state included.

The states "Power Down" and "Power Up" are thus functionally identical except for the indication: PD = 1111 and PU = 0111.

With the C/I command Timing (TIM) the microcontroller can enforce the "Power Up" state and with C/I command Deactivation Indication (DI) the "Power Down" state is reached again.

However, it is also possible to activate the S-interface directly with the C/I command Activate Request (AR 8/10/L) without the TIM command.

1: The IOM interface clock and frame signals are normally inactive ("Power Down").

For activating the IOM-2 clocks the "Power Up" state can be induced by software (IOM_CR.SPU) or by resetting CFS again.

After that the S-interface can be activated with the C/I command Activate Request (AR 8/10/L). The "Power Down" state can be reached again with the C/I command Deactivation Indication (DI).

Note: After reset the IOM interface is always active. To reach the "Power Down" state the CFS-bit has to be set.

For general information please refer to [Chapter 3.3.8](#).

RSS2, RSS1... Reset Source Selection 2,1

The ISAC-SX TE reset sources for the $\overline{\text{RSTO}}$ output pin can be selected according to the table below.

RSS		C/I Code Change	EAW	Watchdog Timer
Bit 1	Bit 0			
0	0	--	--	--
0	1	(reserved)		
1	0	x	x	--
1	1	--	--	x

- If RSS = '00' no above listed reset source is selected and therefore no reset is generated at $\overline{\text{RSTO}}$.

- **Watchdog Timer**

After the selection of the watchdog timer (RSS = '11') the timer is reset and started. During every time period of 128 ms the microcontroller has to program the WTC1 and WTC2 bits in two consecutive bit pattern (see description of the WTC1, 2 bits) otherwise the watchdog timer expires and a reset pulse of $125 \mu\text{s} \leq t \leq 250 \mu\text{s}$ is generated. Deactivation of the watchdog timer is only possible with a hardware reset.

Detailed Register Description

- If RSS = '10' is selected the following two reset sources generate a reset pulse of $125\ \mu\text{s} \leq t \leq 250\ \mu\text{s}$ at the $\overline{\text{RSTO}}$ pin:
 - **External (Subscriber) Awake ($\overline{\text{EAW}}$)**
The $\overline{\text{EAW}}$ input pin serves as a request signal from the subscriber to initiate the awake function in a terminal and generates a reset pulse (in TE mode only).
 - **Exchange Awake (C/I Code)**
A C/I Code change generates a reset pulse.

After a reset pulse generated by the ISAC-SX TE and the corresponding interrupt (WOV or CIC) the actual reset source can be read from the ISTA.

4.4.6 MODE2 - Mode2 Register

Value after reset: 00_H

	7							0	
MODE2	0	0	0	0	INT_ POL	0	0	PPSDX	RD/WR (63)

INT_POL ... Interrupt Polarity

Selects the polarity of the interrupt pin $\overline{\text{INT}}$.
 0: low active with open drain characteristic (default)
 1: high active with push pull characteristic

PPSDX ... Push/Pull Output for SDX (SCI Interface)

0: The SDX pin has open drain characteristic
 1: The SDX pin has push/pull characteristic

4.4.7 ID - Identification Register

Value after reset: 01_H

	7							0	
ID	0	0	DESIGN						RD (64)

DESIGN ... Design Number

The design number allows to identify different hardware designs of the ISAC-SX TE by software.

01_H: V 1.4

(all other codes reserved)

4.4.8 SRES - Software Reset Register

Value after reset: 00_H

	7							0	
SRES	RES_ CI	0	0	RES_ MON	RES_ DCH	RES_ IOM	RES_ TR	RES_ RSTO	WR (64)

RES_xx ... Reset Functional Block xx

A reset can be activated on the functional block C/I-handler, Monitor channel, D-channel, IOM handler, S-transceiver and to pin $\overline{\text{RSTO}}$.

Setting one of these bits to "1" causes the corresponding block to be reset for a duration of 4 BCL clock cycles, except RES_RSTO which is activated for a duration of 125 ... 250µs. The bits are automatically reset to "0" again.

4.4.9 TIMR2 - Timer 2 Register

Value after reset: 00_H

	7					0	
TIMR2	TMD	0	CNT				RD/WR (65)

TMD ... Timer Mode

Timer 2 can be used in two different modes of operation.

0: Count Down Timer. An interrupt is generated only once after a time period of 1...63 ms.

1: Periodic Timer. An interrupt is periodically generated every 1 ... 63 ms (see CNT).

CNT ... Timer Counter

0: Timer off.

1 ... 63: Timer period = 1 ... 63 ms

Detailed Register Description

By writing '0' to CNT the timer is immediately stopped. A value different from that determines the time period after which an interrupt will be generated.

If the timer is already started with a certain CNT value and is written again before an interrupt has been released, the timer will be reset to the new value and restarted again. An interrupt is indicated to the host in AUXI.TIN2.

Note: Reading back this value delivers back the current counter value which may differ from the programmed value if the counter is running.

5 Electrical Characteristics

5.1 Absolute Maximum Ratings

Parameter	Symbol	Limit Values		Unit
		min.	max.	
Ambient temperature under bias	T_A	0	+70	°C
Storage temperature	T_{STG}	- 55	150	°C
Input/output voltage on any pin with respect to ground	V_S	- 0.3	5.25	V
Maximum voltage on any pin with respect to ground	V_{max}		5.5	V

Note: Stresses above those listed here may cause permanent damage to the device. Exposure to absolute maximum rating conditions for extended periods may affect device reliability. Maximum ratings are absolute ratings; exceeding only one of these values may cause irreversible damage to the integrated circuit. The supply voltage must show a monotonic rise.

5.2 DC Characteristics
 $V_{DD}/V_{SS} = 3.3 \text{ V} \pm 5\%$; $T_A = 0 \text{ to } 70 \text{ }^\circ\text{C}$

Parameter	Symbol	Limit Values			Unit	Test Condition
		min.	typ.	max.		
H-input level (except pin SR1/2)	V_{IH}	2.0		5.5	V	
L-input level (except pin SR1/2)	V_{IL}	- 0.3		0.8	V	
H-output level (except pin XTAL2, SX1/2)	V_{OH}	2.4			V	$I_{OH} = - 4.5 \text{ mA}$ (AD0-7) $I_{OH} = - 400 \text{ } \mu\text{A}$ (all others)
L-output level (except pin XTAL2, SX1/2)	V_{OL}			0.45	V	$I_{OL} = 6 \text{ mA}$ (DU, DD, C768) $I_{OL} = 4.5 \text{ mA}$ ($\overline{\text{ACL}}$, AUX7, AUX6, AD0-7) $I_{OL} = 2 \text{ mA}$ (all others)
Input leakage current Output leakage current (all pins except SX1/2, SR1/2, XTAL1/2, AUX7/6)	I_{LI} I_{LO}			± 1 ± 1	μA μA	$0\text{V} < V_{IN} < V_{DD}$ $0\text{V} < V_{OUT} < V_{DD}$
Input leakage current Output leakage current (AUX7/6)	I_{LI} I_{LO}	50 50		200 200	μA μA	$0\text{V} < V_{IN} < V_{DD}$ $0\text{V} < V_{OUT} < V_{DD}$ (only if AUX7/6 is input or output/open- drain; not relevant if output/push-pull)
Power supply current- Power Down - Clocks Off	I_{PD1}			300	μA	Inputs at V_{SS} / V_{DD} No output loads except SX1,2 (50 Ω)
- Clocks On	I_{PD2}			3	mA	
Power supply current - S operational (96 kHz)	I_{OP1}			30	mA	
- B1= 00 _H , B2= FF _H , D= 0	I_{OP2}			25	mA	

5.3 Capacitances

$T_A = 25\text{ }^\circ\text{C}$, $V_{DD} = 3.3\text{ V} \pm 5\%$, $V_{SSA} = 0\text{ V}$, $V_{SS} = 0\text{ V}$, $f_c = 1\text{ MHz}$, unmeasured pins grounded.

Parameter	Symbol	Limit Values		Unit	Remarks
		min.	max.		
Input Capacitance	C_{IN}		7	pF	All pins except SX1,2 and XTAL1,2
I/O Capacitance	$C_{I/O}$		7	pF	
Output Capacitance against V_{SS}	C_{OUT}		10	pF	pins SX1,2

5.4 Oscillator Specification

Recommended Oscillator Circuits

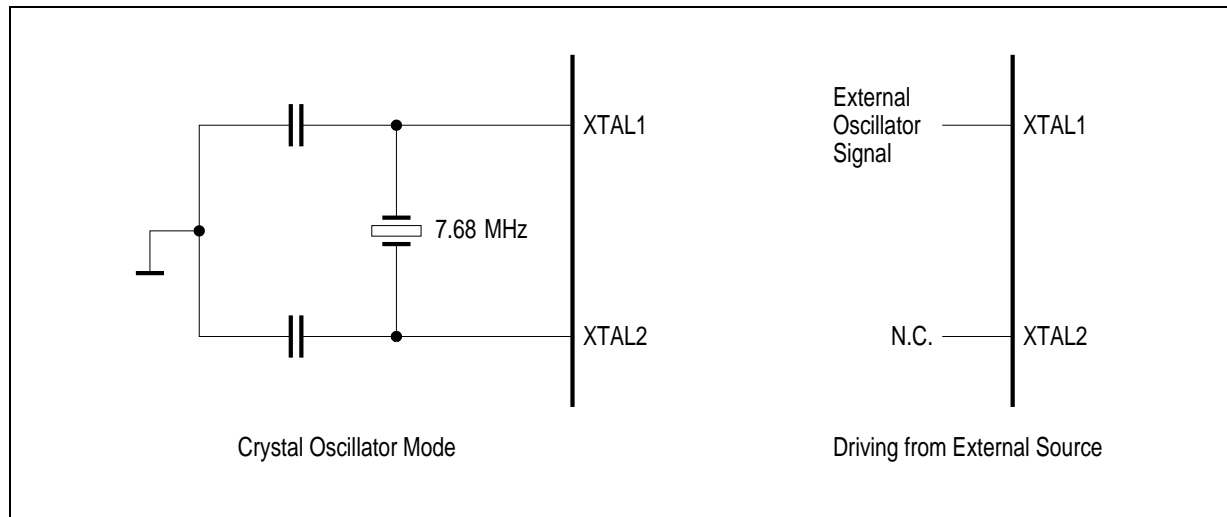

Figure 70 Oscillator Circuits

Parameter	Symbol	Limit Values	Unit
Frequency	f	7.680	MHz
Frequency calibration tolerance		max. 100	ppm
Load capacitance	C_L	max. 40	pF
Oscillator mode		fundamental	

Note: It is important to note that the load capacitance depends on the recommendation of the crystal specification. Typical values are 22 ... 33 pF.

XTAL1 Clock Characteristics (external oscillator input)

Parameter	Limit Values	
	min.	max.
Duty cycle	1:2	2:1

5.5 AC Characteristics

$T_A = 0$ to 70 °C, $V_{DD} = 3.3$ V \pm 5%

Inputs are driven to 2.4 V for a logical "1" and to 0.45 V for a logical "0". Timing measurements are made at 2.0 V for a logical "1" and 0.8 V for a logical "0". The AC testing input/output waveforms are shown in **figure 71**.

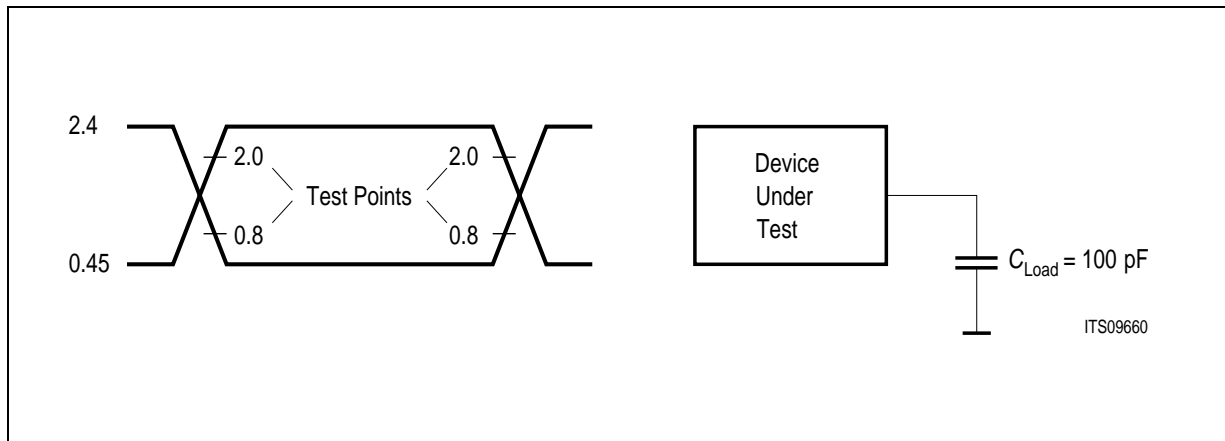

Figure 71 Input/Output Waveform for AC Tests

5.6 IOM-2 Interface Timing

Data is transmitted with the rising edge of DCL and sampled with its falling edge. Below figure shows double clock mode timing (the length of a timeslot is 2 DCL cycles), however, the timing parameters are valid both in single and double clock mode.

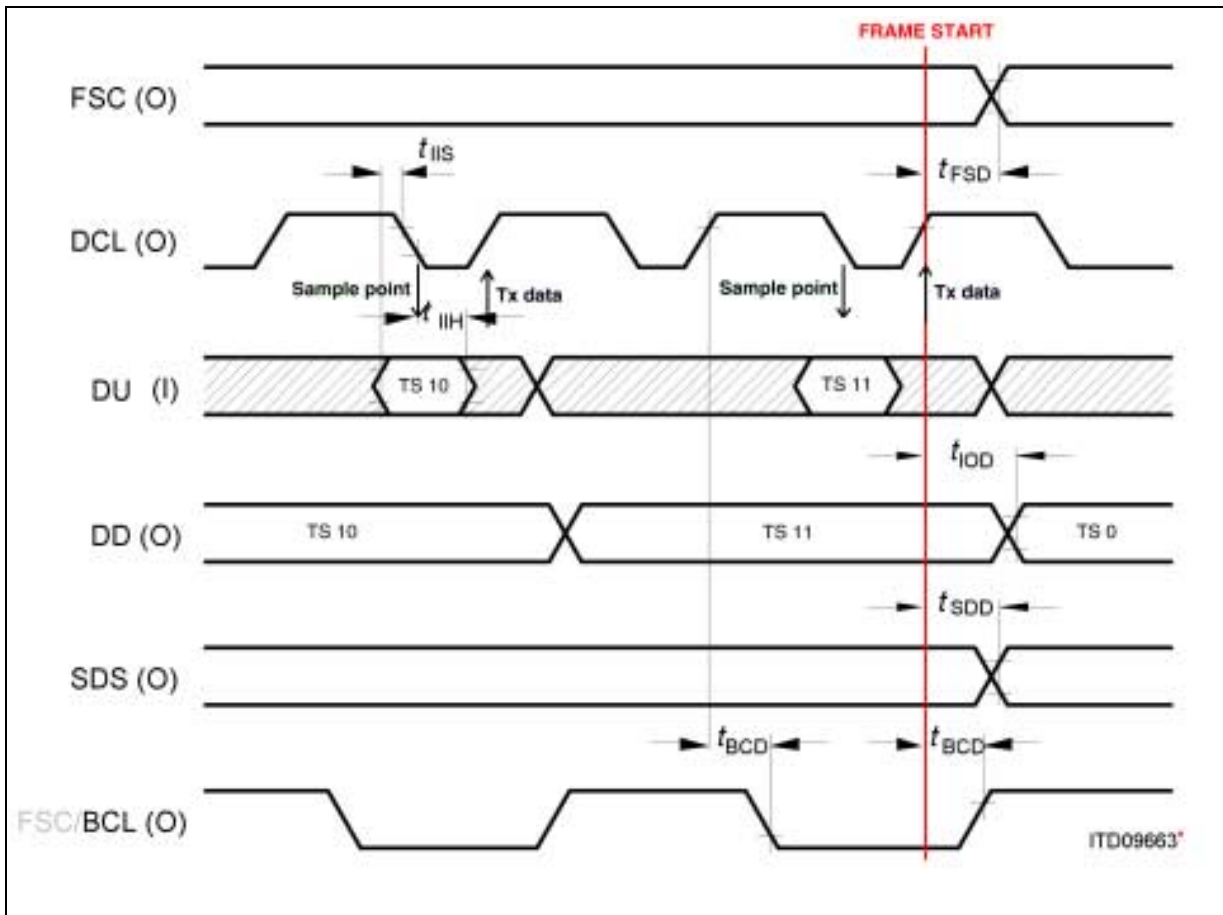

Figure 72 IOM-2 Timing (TE mode)

Parameter	Symbol	Limit Values		Unit
		min.	max.	
IOM output data delay	t_{IOD}		60	ns
IOM input data setup	t_{IIS}	4		ns
IOM input data hold	t_{IIH}	3		ns
FSC strobe delay (see note)	t_{FSD}	-135	15	ns
Strobe signal delay	t_{SDD}		50	ns
BCL / FSC delay	t_{BCD}		30	ns

Note: Min. value in synchronous state, max. value in non-synchronous state. This results in a phase shift of FSC when the S-Bus gets activated, this is the FSC signal is shifted by 135 ns.

DCL Clock Output Characteristics

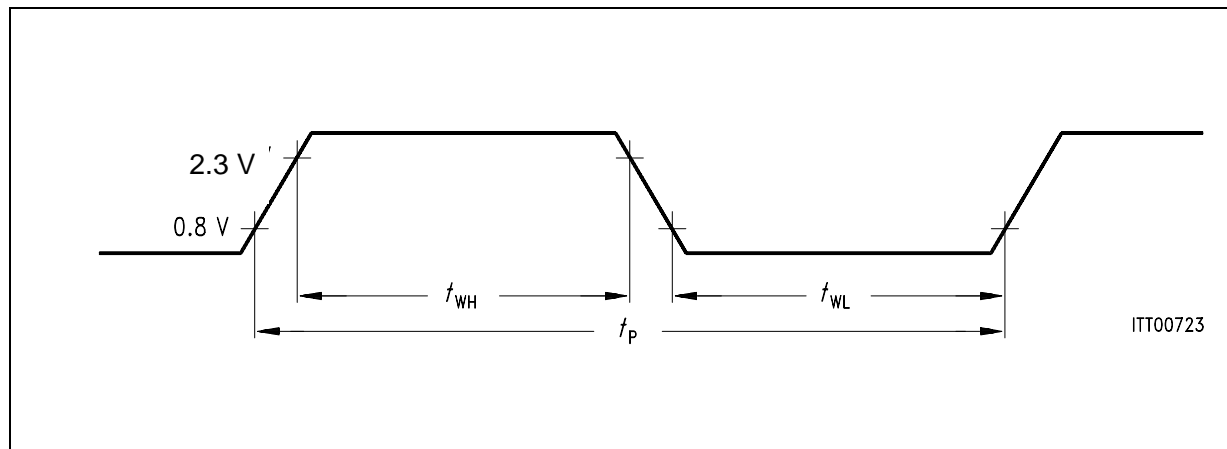

Figure 73 Definition of Clock Period and Width

Symbol	Limit Values			Unit	Test Condition
	min.	typ.	max.		
t_P	585	651	717	ns	osc \pm 100 ppm
t_{WH}	260	325	391	ns	osc \pm 100 ppm
t_{WL}	260	325	391	ns	osc \pm 100 ppm

DCL Clock Input Characteristics

Parameter	Limit Values		Unit
	min.	max.	
Duty cycle	40	60	%

Note: In normal mode the IOM clocks are output only. If the transceiver is disabled ($DIS_TR = 1$) the IOM clocks become input and e.g. the HDLC controller can still operate via the IOM-2 interface.

5.7 Microcontroller Interface Timing

5.7.1 Serial Control Interface (SCI) Timing

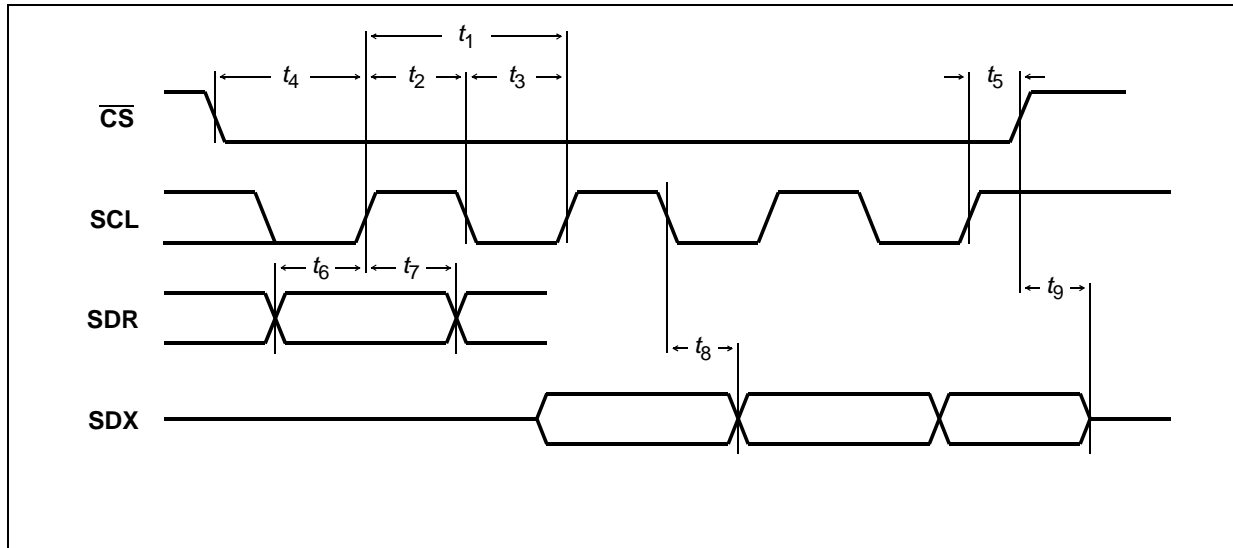

Figure 74 SCI Interface

Parameter SCI Interface	Symbol	Limit Values		Unit
		min.	max.	
SCL cycle time	t_1	200		ns
SCL high time	t_2	100		ns
SCL low time	t_3	100		ns
\overline{CS} setup time	t_4	2		ns
\overline{CS} hold time	t_5	10		ns
SDR setup time	t_6	10		ns
SDR hold time	t_7	6		ns
SDX data out delay	t_8		30	ns
\overline{CS} high to SDX tristate	t_9		40	ns

5.7.2 Parallel Microcontroller Interface Timing

Siemens/Intel Bus Mode

The data read and write timing is the same for multiplexed and non multiplexed bus operation (**Figure 75** and **Figure 76**). **Figure 77** shows the corresponding address timing in multiplexed mode and **Figure 78** in non multiplexed mode.

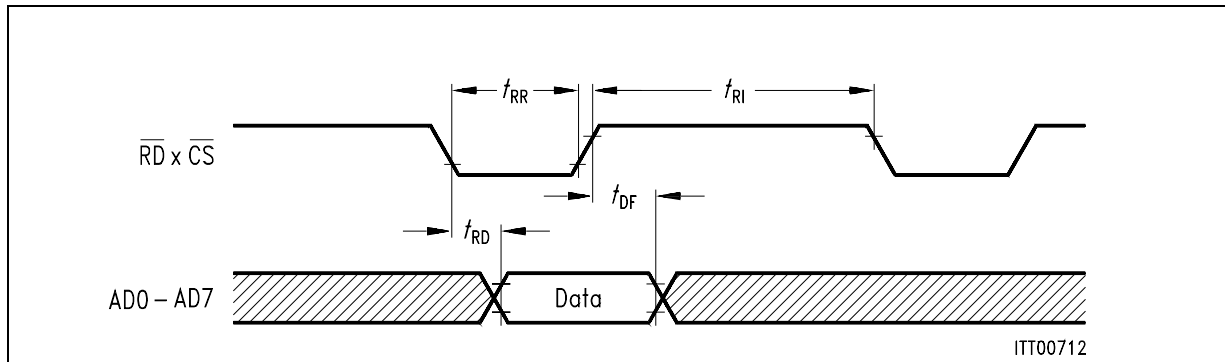

Figure 75 Microprocessor Read Cycle

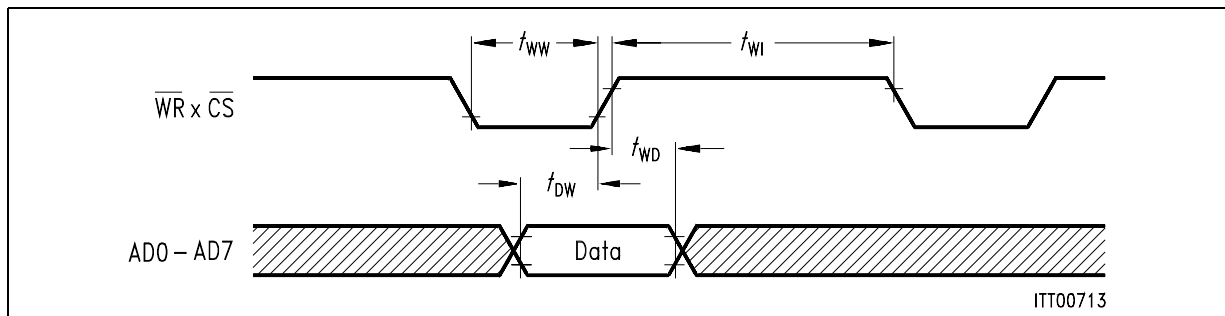

Figure 76 Microprocessor Write Cycle

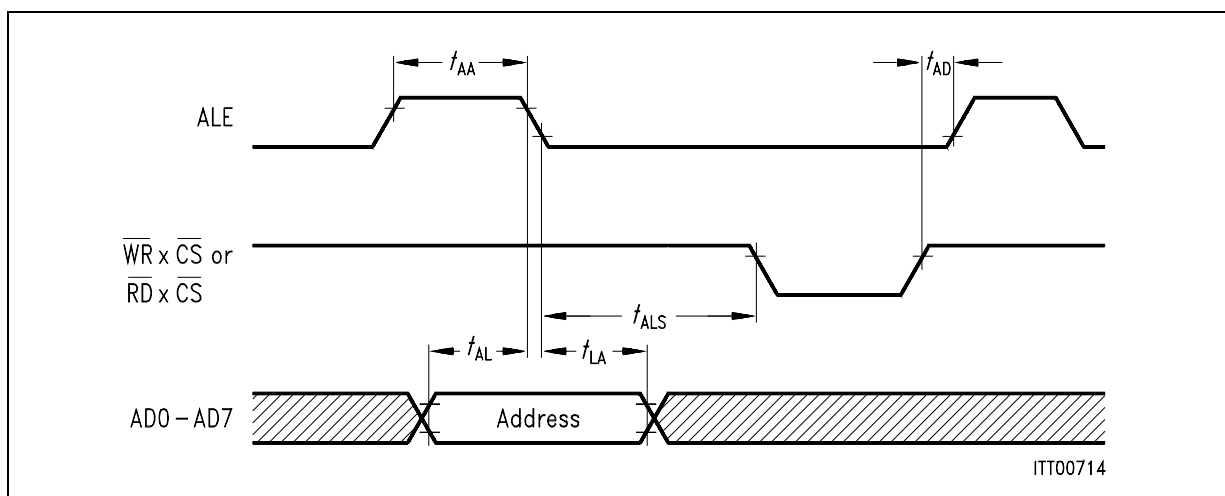

Figure 77 Multiplexed Address Timing

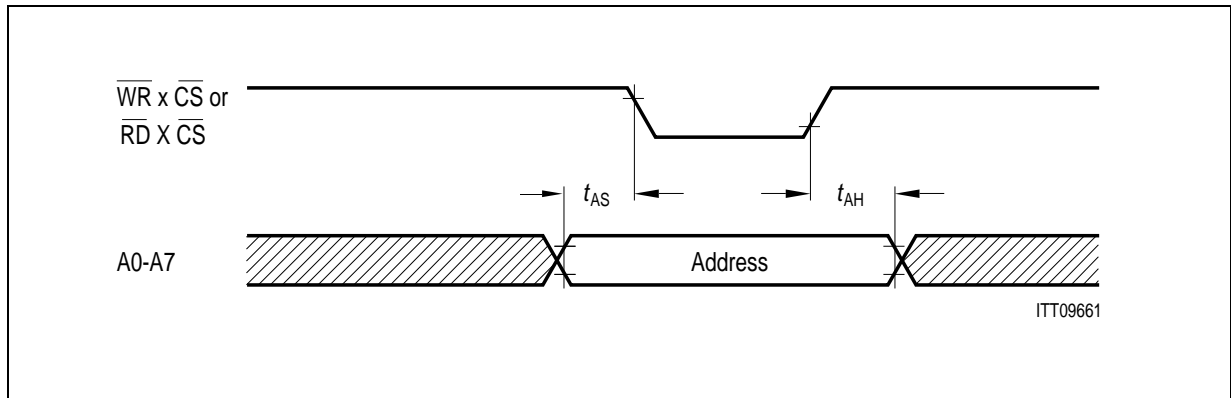

Figure 78 Non-Multiplexed Address Timing

Motorola Bus Mode

The Motorola Bus is non multiplexed. The data timing is shown in [Figure 79](#) (read) and [Figure 80](#) (write). The corresponding address timing (for both read and write) is shown in [Figure 81](#).

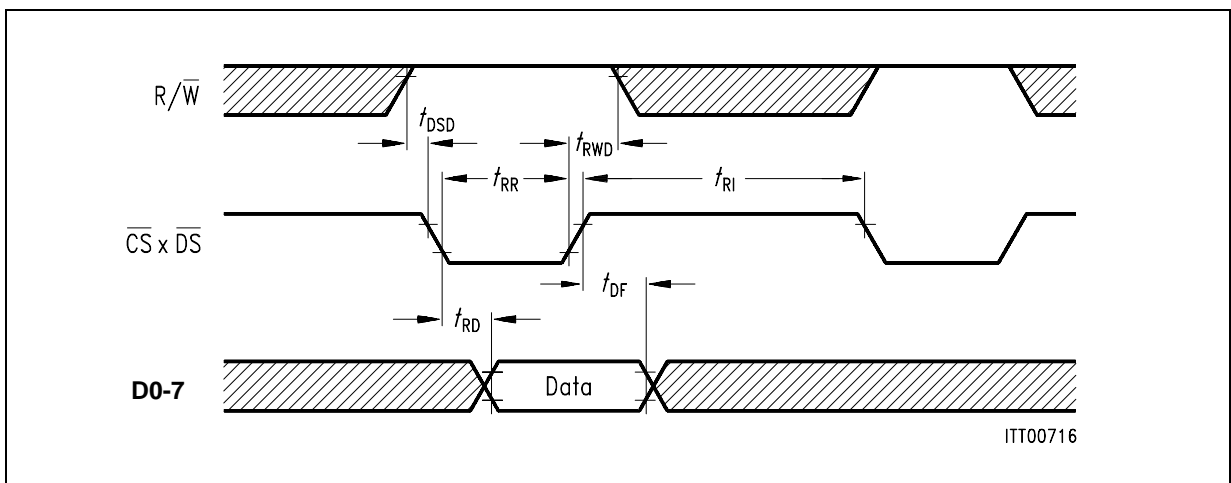

Figure 79 Microprocessor Read Timing

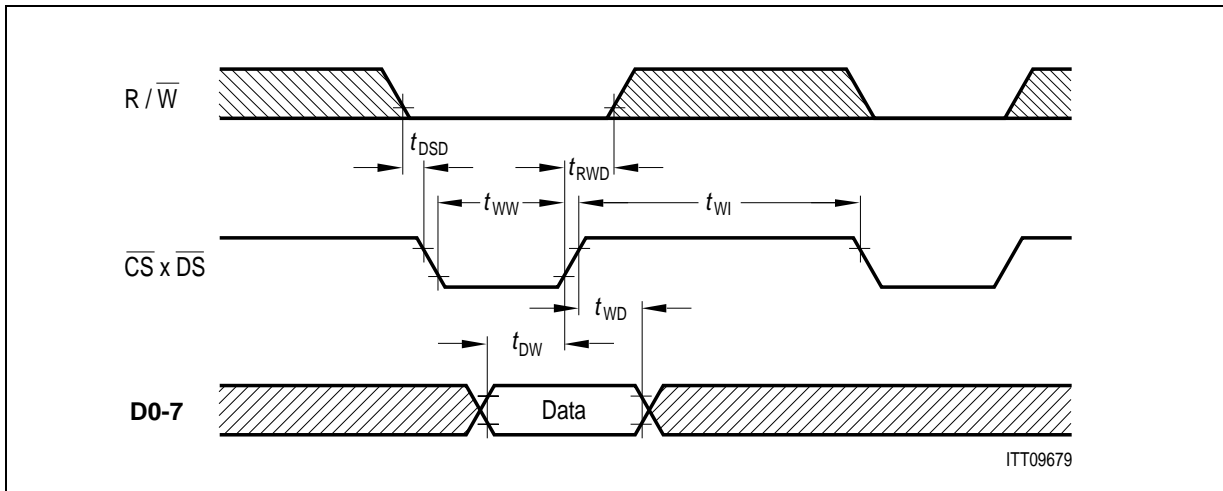

Figure 80 Microprocessor Write Cycle

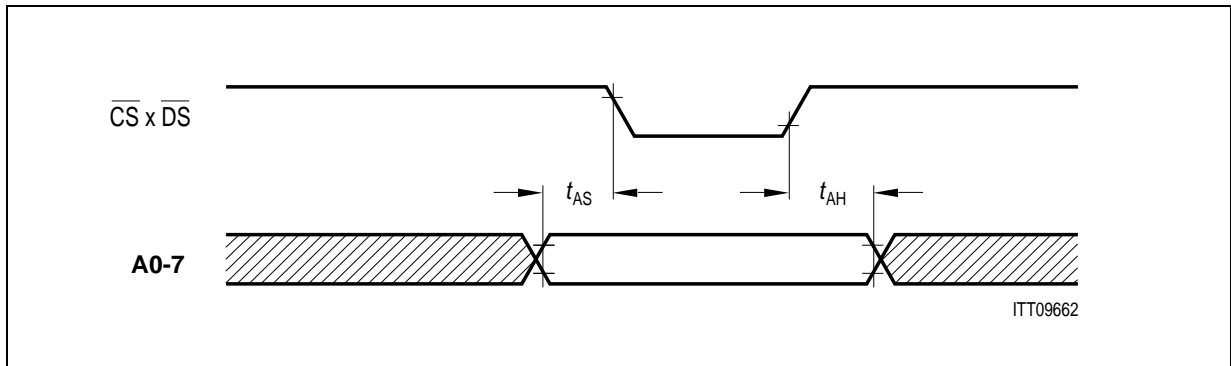

Figure 81 Non-Multiplexed Address Timing

Microprocessor Interface Timing

Parameter	Symbol	Limit Values		Unit
		min.	max.	
ALE pulse width	t_{AA}	20		ns
Address setup time to ALE	t_{AL}	5		ns
Address hold time from ALE	t_{LA}	3		ns
Address latch setup time to \overline{WR} , \overline{RD}	t_{ALS}	10		ns
Address setup time	t_{AS}	10		ns
Address hold time	t_{AH}	3		ns
ALE guard time	t_{AD}	15		ns
\overline{DS} delay after $\overline{R/\overline{W}}$ setup	t_{DSD}	3		ns
\overline{RD} pulse width	t_{RR}	100		ns
Data output delay from \overline{RD}	t_{RD}		80	ns
Data float from \overline{RD}	t_{DF}		25	ns
\overline{RD} control interval	t_{RI}	70		ns
\overline{W} pulse width	t_{WW}	10		ns
Data setup time to $\overline{W} \times \overline{CS}$	t_{DW}	10		ns
Data hold time $\overline{W} \times \overline{CS}$	t_{WD}	2		ns
\overline{W} control interval	t_{WI}	70		ns
$\overline{R/\overline{W}}$ hold from $\overline{CS} \times \overline{DS}$ inactive	t_{RWD}	2		ns

5.8 Reset

Parameter	Symbol	Limit Values	Unit	Test Conditions
		min.		
Length of active low state	t_{RES}	4	ms	Power On/Power Down to Power Up (Standby)
		2 x DCL clock cycles		During Power Up (Standby)

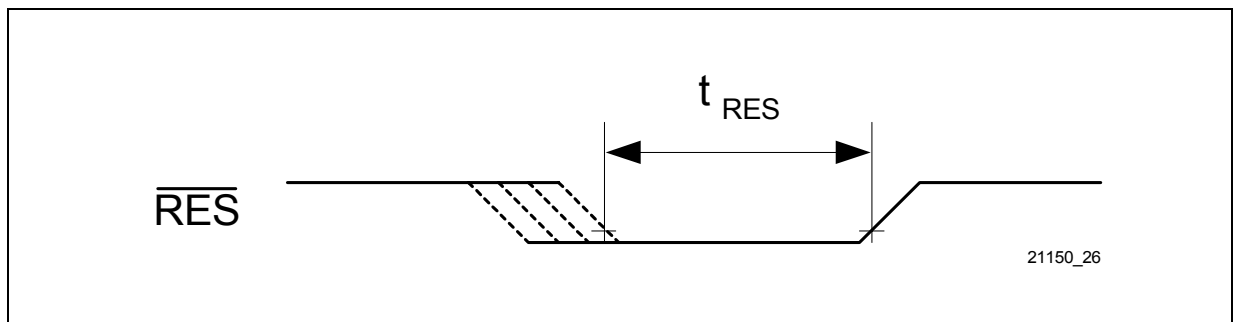

Figure 82 Reset Signal \overline{RES}

5.9 S-Transceiver

Parameter	Symbol	Limit Values			Unit	Test Condition
		min.	typ.	max.		
$V_{DD} = 3.3 \text{ V} \pm 5\%$; $V_{SS} = 0 \text{ V}$; $T_A = 0 \text{ to } 70 \text{ }^\circ\text{C}$						
Absolute value of output pulse amplitude $ V_{SX2} - V_{SX1} $	V_X			1.17	V	$R_L = \infty$
Transmitter output current	I_X			26	mA	$R_L = 5.6 \text{ } \Omega$
Transmitter output impedance (SX1,2)	Z_X	10 0			k Ω Ω	Inactive or during binary one; during binary zero $R_L = 50 \text{ } \Omega$
Receiver Input impedance (SR1,2)	Z_R	30			k Ω	$V_{DD} = 3.3 \text{ V}$

5.10 Recommended Transformer Specification

Parameter	Symbol	Limit Values			Unit	Test Condition
		min.	typ.	max.		
Transformer ratio			1:1			
Main inductance	L	25 20			mH mH	no DC current, 10 kHz 2.5 mA DC current, 10 kHz
Leakage inductance	L _L			6	μH	TE mode, 10 kHz
Capacitance between primary and secondary side	C			80	pF	1 kHz
Copper resistance	R	1.7	2.0	2.3	Ω	

Note: In TE mode, at the pulse shape measurement with a load of 400 Ω (e.g. K 1403 approval test "Pulse shape") overshoots might occur with a leakage inductance greater than 6 μH.

5.11 Line Overload Protection

The maximum input current for the S-transceiver lines (under overvoltage conditions) is given as a function of the width of a rectangular input current pulse. The destruction limits are shown in [Figure 83](#).

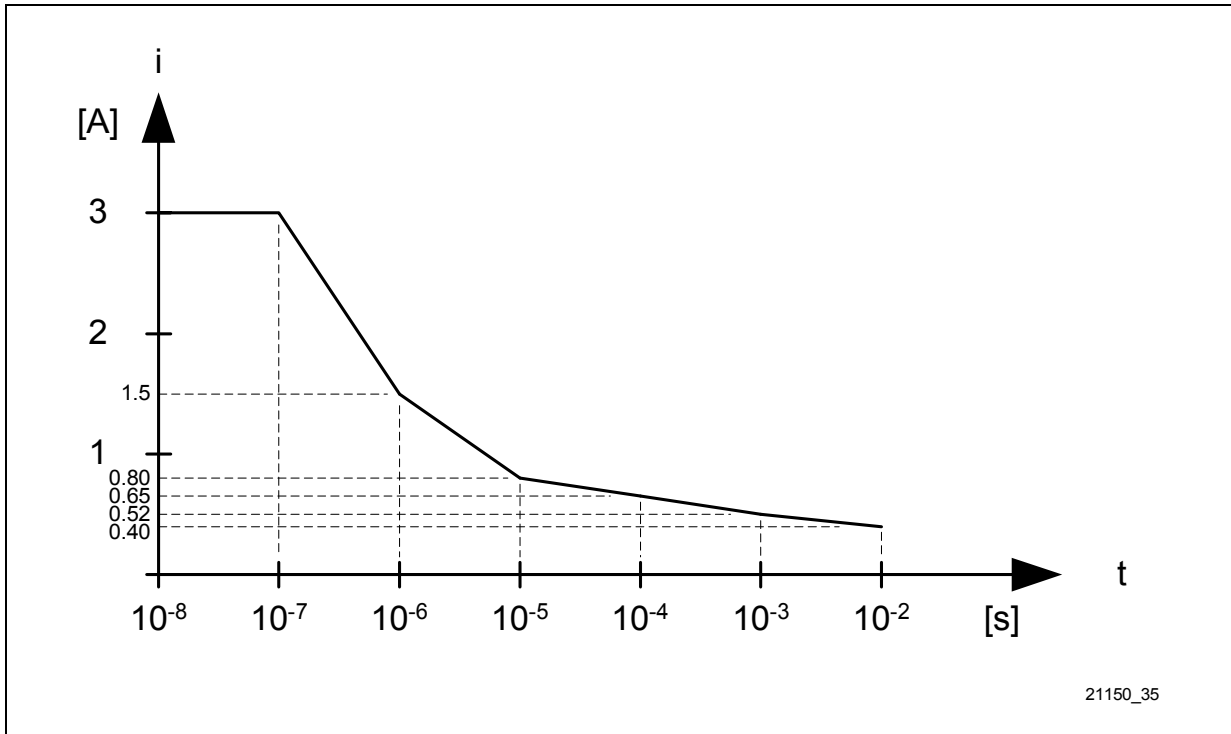

Figure 83 Maximum Line Input Current

5.12 EMC / ESD Aspects

To improve performance with respect to EMC and ESD requirements it is recommended to provide additional capacitors in the middle tap of the transformers (see **Figure 84** below). The values for C1 and C2 should be in the range 1 ... 10 nF. They can be located either on the chip side of the transformer (option 1) or on the S bus side (option 2), but not on both sides.

This improves EMC immunity according to EN55024 which is mandatory since 2001-07-01.

Note: The figure does not show any other components required for protection circuit in receive and transmit direction as this is not affected by including C1 and C2.

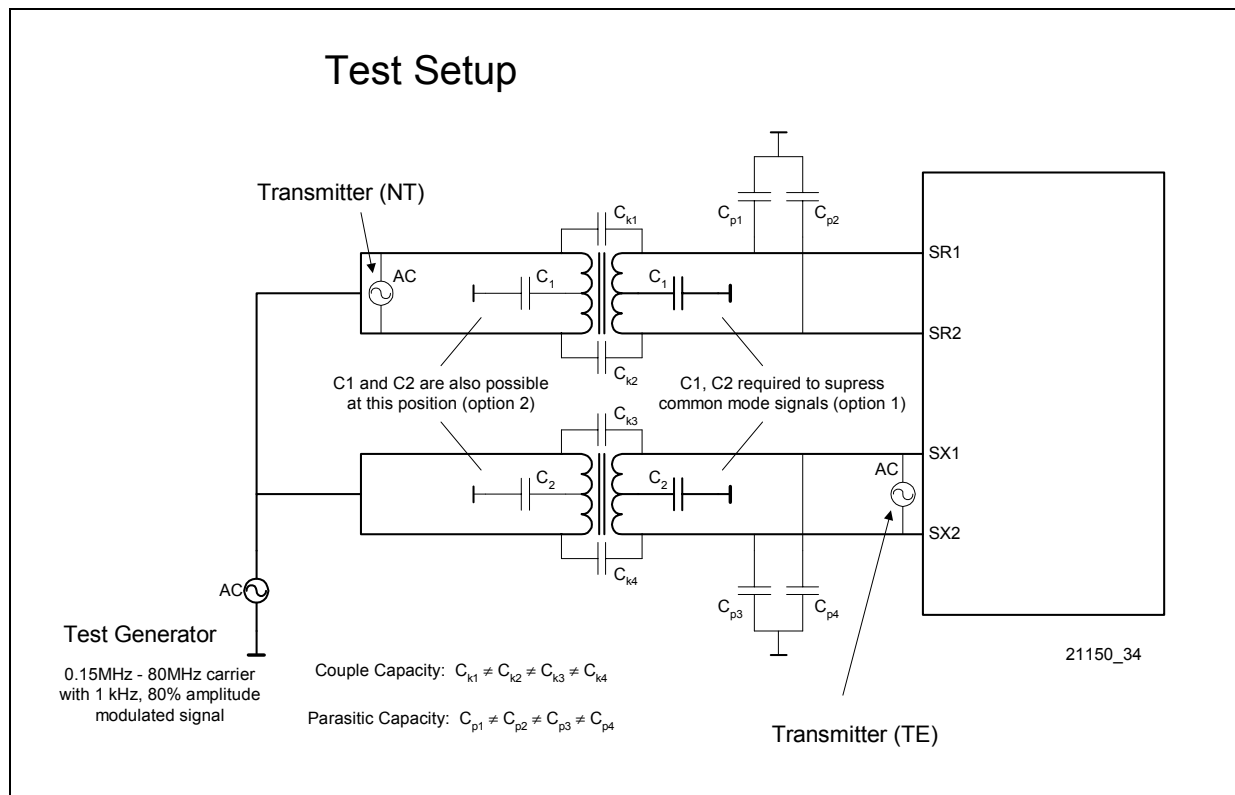
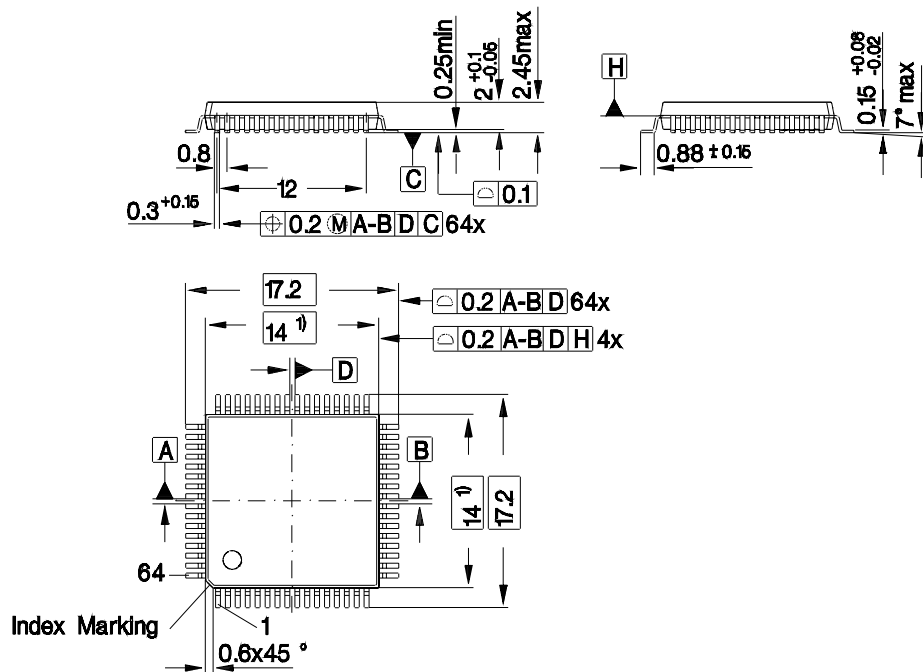

Figure 84 Transformer Circuitry

6 Package Outlines

P-MQFP-64-1

(Plastic Metric Quad Flat Package)



1) Does not include plastic or metal protrusion of 0.25 max. per side

GPM05220

You can find all of the current packages, types of packing, and others on the Infineon Internet Page "Products": <http://www.infineon.com/products>.

SMD = Surface Mounted Device

Dimensions in mm

P-TQFP-64-1
(Plastic Thin Quad Flat Package)

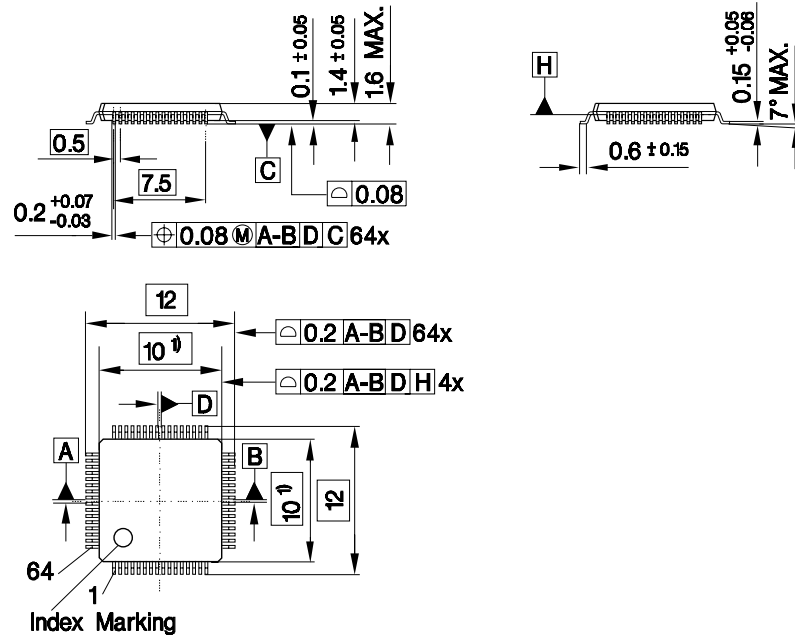

1) Does not include plastic or metal protrusion of 0.25 max. per side

GPM05613

You can find all of the current packages, types of packing, and others on the Infineon Internet Page "Products": <http://www.infineon.com/products>.

SMD = Surface Mounted Device

Dimensions in mm

7 Appendix

D-channel HDLC, C/I-channel Handler

Name	7	6	5	4	3	2	1	0	ADDR	R/W	RES
RFIFOD	D-Channel Receive FIFO								00 _H -1F _H	R	
XFIFOD	D-Channel Transmit FIFO								00 _H -1F _H	W	
ISTAD	RME	RPF	RFO	XPR	XMR	XDU	0	0	20 _H	R	10 _H
MASKD	RME	RPF	RFO	XPR	XMR	XDU	1	1	20 _H	W	FF _H
STARD	XDOV	XFW	0	0	RACI	0	XACI	0	21 _H	R	40 _H
CMDRD	RMC	RRES	0	STI	XTF	0	XME	XRES	21 _H	W	00 _H
MODED	MDS2	MDS1	MDS0	0	RAC	DIM2	DIM1	DIM0	22 _H	R/W	C0 _H
EXMD1	XFBS	RFBS		SRA	XCRC	RCRC	0	ITF	23 _H	R/W	00 _H
TIMR1	CNT			VALUE					24 _H	R/W	00 _H
SAP1	SAPI1						0	MHA	25 _H	W	FC _H
SAP2	SAPI2						0	MLA	26 _H	W	FC _H
RBCLD	RBC7							RBC0	26 _H	R	00 _H
RBCHD	0	0	0	OV	RBC11			RBC8	27 _H	R	00 _H
TEI1	TEI1							EA1	27 _H	W	FF _H
TEI2	TEI2							EA2	28 _H	W	FF _H
RSTAD	VFR	RDO	CRC	RAB	SA1	SA0	C/R	TA	28 _H	R	0F _H
TMD	0	0	0	0	0	0	0	TLP	29 _H	R/W	00 _H
	reserved								2A-2D _H		
CIR0	CODR0				CIC0	CIC1	S/G	BAS	2E _H	R	F3 _H
CIX0	CODX0				TBA2	TBA1	TBA0	BAC	2E _H	W	FE _H

CIR1	CODR1	CICW	CI1E	2F _H	R	FE _H
CIX1	CODX1	CICW	CI1E	2F _H	W	FE _H

Transceiver

NAME	7	6	5	4	3	2	1	0	ADDR	R/W	RES
TR_CONF0	DIS_TR	0	EN_ICV	0	0	0	EXLP	LDD	30 _H	R/W	01 _H
TR_CONF1	0	RPLL_ADJ	EN_SFSC	0	0	x	x	x	31 _H	R/W	
TR_CONF2	DIS_TX	PDS	0	RLP	0	0	0	0	32 _H	R/W	80 _H
TR_STA	RINF		SLIP	ICV	0	FSYN	0	LD	33 _H	R	00 _H
	reserved								34 _H		
SQRR1	MSYN	MFEN	0	0	SQR11	SQR12	SQR13	SQR14	35 _H	R	40 _H
SQXR1	0	MFEN	0	0	SQX11	SQX12	SQX13	SQX14	35 _H	W	4F _H
SQRR2	SQR21	SQR22	SQR23	SQR24	SQR31	SQR32	SQR33	SQR34	36 _H	R	00 _H
	reserved								36 _H	W	
SQRR3	SQR41	SQR42	SQR43	SQR44	SQR51	SQR52	SQR53	SQR54	37 _H	R	00 _H
	reserved								37 _H	W	
ISTATR	0	x	x	x	LD	RIC	SQC	SQW	38 _H	R	00 _H
MASKTR	1	1	1	1	LD	RIC	SQC	SQW	39 _H	R/W	FF _H
	reserved								3A _H - 3B _H		
ACFG2	0	0	0	0	ACL	LED	0	0	3C _H	R/W	00 _H
	reserved								3D _H - 3F _H		

**IOM Handler (Timeslot , Data Port Selection,
CDA Data and CDA Control Register)**

Name	7	6	5	4	3	2	1	0	ADDR	R/W	RES
CDA10	Controller Data Access Register (CH10)								40 _H	R/W	FF _H
CDA11	Controller Data Access Register (CH11)								41 _H	R/W	FF _H
CDA20	Controller Data Access Register (CH20)								42 _H	R/W	FF _H
CDA21	Controller Data Access Register (CH21)								43 _H	R/W	FF _H
CDA_ TSDP10	DPS	0	0	TSS					44 _H	R/W	00 _H
CDA_ TSDP11	DPS	0	0	TSS					45 _H	R/W	01 _H
CDA_ TSDP20	DPS	0	0	TSS					46 _H	R/W	80 _H
CDA_ TSDP21	DPS	0	0	TSS					47 _H	R/W	81 _H
	reserved								48 _H - 4B _H		
TR_ TSDP_ BC1	DPS	0	0	TSS					4C _H	R/W	
TR_ TSDP_ BC2	DPS	0	0	TSS					4D _H	R/W	
CDA1_ CR	0	0	EN_ TBM	EN_I1	EN_I0	EN_O1	EN_O0	SWAP	4E _H	R/W	00 _H
CDA2_ CR	0	0	EN_ TBM	EN_I1	EN_I0	EN_O1	EN_O0	SWAP	4F _H	R/W	00 _H

**IOM Handler (Control Registers, Synchronous Transfer
Interrupt Control), MONITOR Handler**

Name	7	6	5	4	3	2	1	0	ADDR	R/W	RES
TR_CR (CI_CS=0)	EN_D	EN_B2R	EN_B1R	EN_B2X	EN_B1X	CS2-0			50 _H	R/W	
TRC_CR (CI_CS=1)	0	0	0	0	0	CS2-0			50 _H	R/W	
	reserved								51 _H		
	reserved								52 _H		
DCI_CR (CI_CS=0)	DPS_CI1	EN_CI1	D_EN_D	D_EN_B2	D_EN_B1	CS2-0			53 _H	R/W	
DCIC_CR (CI_CS=1)	0	0	0	0	0	CS2-0			53 _H	R/W	
MON_CR	DPS	EN_MON	0	0	0	CS2-0			54 _H	R/W	
SDS_CR	ENS_TSS	ENS_TSS+1	ENS_TSS+3	TSS					55 _H	R/W	00 _H
	reserved								56 _H		
IOM_CR	SPU	0	CI_CS	TIC_DIS	EN_BCL	CLKM	DIS_OD	DIS_IOM	57 _H	R/W	08 _H
STI	STOV_21	STOV_20	STOV_11	STOV_10	STI_21	STI_20	STI_11	STI_10	58 _H	R	00 _H
ASTI	0	0	0	0	ACK_21	ACK_20	ACK_11	ACK_10	58 _H	W	00 _H
MSTI	STOV_21	STOV_20	STOV_11	STOV_10	STI_21	STI_20	STI_11	STI_10	59 _H	R/W	FF _H
SDS_CONF	0	0	0	0	DIOM_INV	DIOM_SDS	0	SDS_BCL	5A _H	R/W	00 _H
MCDA	MCDA21		MCDA20		MCDA11		MCDA10		5B _H	R	FF _H

MOR	MONITOR Receive Data								5C _H	R	FF _H
MOX	MONITOR Transmit Data								5C _H	W	FF _H
MOSR	MDR	MER	MDA	MAB	0	0	0	0	5D _H	R	00 _H
MOCR	MRE	MRC	MIE	MXC	0	0	0	0	5E _H	R/W	00 _H
MSTA	0	0	0	0	0	MAC	0	TOUT	5F _H	R	00 _H
MCONF	0	0	0	0	0	0	0	TOUT	5F _H	W	00 _H

Interrupt, General Configuration Registers

NAME	7	6	5	4	3	2	1	0	ADDR	R/W	RES
ISTA	0	0	ST	CIC	AUX	TRAN	MOS	ICD	60 _H	R	00 _H
MASK	1	1	ST	CIC	AUX	TRAN	MOS	ICD	60 _H	W	FF _H
AUXI	0	0	EAW	WOV	TIN2	TIN1	0	0	61 _H	R	00 _H
AUXM	1	1	EAW	WOV	TIN2	TIN1	1	1	61 _H	W	FF _H
MODE1	0	0	0	WTC1	WTC2	CFS	RSS2	RSS1	62 _H	R/W	00 _H
MODE2	0	0	0	0	INT_ POL	0	0	PPSDX	63 _H	R/W	00 _H
ID	0	0	DESIGN						64 _H	R	01 _H
SRES	RES_ CI	0	0	RES_ MON	RES_ DCH	RES_ IOM	RES_ TR	RES_ RSTO	64 _H	W	00 _H
TIMR2	TMD	0	CNT						65 _H	R/W	00 _H
	reserved								66 _H - 6F _H		

Index**A**

Absolute maximum ratings 172
AC characteristics 176
ACFG2 register 149
ACKxy bits 159
ACL bit 149
Activation 67
Activation indication - pin ACL 38
Activation LED 38
Activation/deactivation of IOM-2 interface
 100
Appendix 191
Applications 18
Architecture 25
ASTI register 159
AUX bit 165
AUXI register 166
AUXM register 167

B

BAC bit 141
BAS bit 140
Bus operation modes 31

C

C/I channel 93
C/R bit 138
Capacitances 174
CDA_TSDPxy registers 151
CDAx_CR register 152
CDAxy registers 151
CFS bit 167
CI_CS bit 157
CI1E bit 142
CIC bit 165
CIC1/0 bits 140
CICW bit 142
CIR0 register 140
CIR1 register 142
CIX0 register 141
CIX1 register 142
CLKM bit 157

Clock generation 54
CMDR register 131
CNT bits 135, 170
CODR0 bits 140
CODR1 bits 142
CODX0 bits 141
CODX1 bits 142
Control of layer-1 57
Controller data access 72
CRC bit 138

D

D_EN_B2/1 bits 154
D_EN_D bit 154
DC characteristics 173
D-channel access control
 S-bus priority mechanism 97
 TIC bus 95
DCI_CR register 154
DCIC_CR register 155
Deactivation 67
Delay between IOM-2 and S 44
DESIGN bits 169
Device architecture 25
DIM2-0 bits 132
DIOM_INV bit 160
DIOM_SDS bit 160
Direct address mode 32
DIS_IOM bit 157
DIS_OD bit 157
DIS_TR bit 144
DIS_TX bit 145
DPS bit 151, 156
DPS_CI1 bit 154

E

EA1 bit 137
EA2 bit 138
EAW bit 166
Electrical characteristics 172
EN_B2/1R bits 153
EN_B2/1X bits 153
EN_BCL bit 157

Index

EN_CI1 bit 154
EN_D bit 153
EN_I0 bit 152
EN_I1 bit 152
EN_ICV bit 144
EN_MON bit 156
EN_O0 bit 152
EN_O1 bit 152
EN_SFSC bit 145
EN_TBM bit 152
ENS_TSSx bits 156
Exchange awake 35
EXLP bit 144
EXMD1 register 134
Extended transparent mode 117
External reset input 35

F

Features 15
FSYN bit 146
Functional blocks 25

H

HDLC controllers
 Access to IOM channels 117
 Data reception 104
 Data transmission 112
 Extended transparent mode 117
 Interrupts 118
 Receive frame structure 109
 Test functions 119
 Transmit frame structure 116

I

ICD bit 165
ICV bit 146
ID register 169
Indirect address mode 32
INT_POL bit 169
Interrupt structure 33
IOM_CR register 157
IOM-2 68
 Frame structure (TE) 69

 Handler 70
 Interface Timing 177
 Monitor channel 84
ISTA register 165
ISTAD register 128
ISTATR register 148
ITF bit 134

J

Jitter 55

L

LD bit 146, 148
LDD bit 144
LED bit 149
LED output 38
Level detection 50
Logic symbol 17
Looping data 73

M

MAB bit 162
MAC bit 163
MASK register 166
MASKD register 130
MASKTR register 149
MCDA register 161
MCDAXy bits 161
MCONF register 164
MDA bit 162
MDR bit 162
MDS2-0 bits 132
MER bit 162
MFEN bit 147
MHA bit 135
Microcontroller interface timing 179
Microcontroller interfaces 27
MIE bit 162
MLA bit 136
MOCR register 162
MODE1 register 167
MODE2 register 169
MODED register 132

Index

MON_CR register 156
Monitor channel
 Error treatment 89
 Handshake procedure 86
 Interrupt logic 93
 Master device 91
 Slave device 91
 Time-out procedure 92
Monitoring data 77
MOR register 161
MOS bit 165
MOSR register 162
MOX register 162
MRC bit 162
MRE bit 162
MSTA register 163
MSTI register 160
MSYN bit 147
Multiframing 42
MXC bit 162

O

Oscillator 175
Oscillator clock output 56
OV bit 137
Overview 12

P

Package Outlines 189
Parallel microcontroller interface 31
PDS bit 145
Pin configuration 19
PPSDX bit 169

R

RAB bit 138
RAC bit 132
RACI bit 130
RBC11-8 bits 137
RBC7-0 bits 136
RBCHD register 137
RBCLD register 136
RCRC bit 134

RDO bit 138
Receive PLL 55
Register description 121
RES_xxx bits 170
Reset generation 34
Reset source selection 34
Reset timing 184
RFBS bits 134
RFIFOD register 128
RFO bit 128
RIC bit 148
RINF bit 146
RLP bit 145
RMC bit 131
RME bit 128
RPF bit 128
RPLL_ADJ bit 145
RRES bit 131
RSS2/1 bits 167
RSTAD register 138

S

S/G bit 140
S/T-Interface 39
 Circuitry 47
 Coding 40
 Delay compensation 50
 External protection circuitry 47
 Multiframing 42
 Receiver characteristics 46
 Transceiver enable/disable 51
 Transmitter characteristics 45
SA1/0 bits 138
SAP1 register 135
SAP2 register 136
S-bus priority mechanism 97
SCI - serial control interface 28
SCI interface timing 179
SDS 82
SDS_BCL bit 160
SDS_CONF register 160
SDSx_CR registers 156
Serial data strobe 82

Index

Shifting data 73
SLIP bit 146
Software reset 35
SPU bit 157
SQC bit 148
SQR1-4 bits 147
SQR21-24 bits 148
SQR31-34 bits 148
SQR41-44 bits 148
SQR51-54 bits 148
SQRR1 register 147
SQRR2 register 148
SQRR3 register 148
SQW bit 148
SQX1-4 bits 147
SQXR1 register 147
SRA bit 134
SRES register 170
ST bit 165
STARD register 130
State machine TE mode 59
STI bit 131
STI register 159
STIxy bits 159, 160
Stop/Go bit 140
STOVxy bits 159, 160
Strobed data clock 82
Subscriber awake 35
SWAP bit 152
Synchronous transfer 78

T

TA bit 138
TBA2-0 bits 141
TEI1 register 137
TEI2 register 138
Test functions 52
Test signals 120
TIC bus 95
TIC_DIS bit 157
Timer 35
Timer 1 36
Timer 2 37

TIMR1 register 135
TIMR2 register 170
TIN2/1 bits 166
TLP bit 140
TMD bit 170
TMD register 140
TOUT bit 163, 164
TR_CONF0 register 144
TR_CONF1 register 145
TR_CONF2 register 145
TR_CR register 153
TR_STA register 146
TR_TSDP_BC1/2 registers 151
TRAN bit 165
Transceiver enable/disable 51
Transformer specification 186
TRC_CR register 154
TSS bits 151, 156
Typical applications 18

V

VALUE bits 135
VFR bit 138

W

Watchdog timer 35
WOV bit 166
WTC1/2 bits 167

X

XACI bit 130
XCRC bit 134
XDOV bit 130
XDU bit 128
XFBS bit 134
XFIFOD register 128
XFW bit 130
XME bit 131
XMR bit 128
XPR bit 128
XRES bit 131
XTF bit 131

<http://www.infineon.com>

Published by Infineon Technologies AG