

TOSHIBA Bipolar Linear Integrated Circuit Silicon Monolithic

TA8225HQ, TA8225LQ

45W BTL Audio Amplifier

The TA8225HQ, TA8225LQ is BTL audio power amplifier for consumer application.

It is designed for high power, low distortion and low noise.

It contains various kind of protectors and the function of stand-by SW.

In addition, the functions of output short or over voltage detection and junction temperature are involved.

Features

- High power
 - : P_{OUT} (1) = 45W (typ.)
(V_{CC} = 14.4V, f = 1kHz, THD = 10%, R_L = 2Ω)
 - : P_{OUT} (2) = 40W (typ.)
(V_{CC} = 13.2V, f = 1kHz, THD = 10%, R_L = 2Ω)
 - : P_{OUT} (3) = 24W (typ.)
(V_{CC} = 13.2V, f = 1kHz, THD = 10%, R_L = 4Ω)
- Low thermal resistance
 - : θ_{j-c} = 1.5°C / W (infinite heat sink)
- Excellent output power band width
 - : P_{OUT} (4) = 18W (typ.)
(V_{CC} = 13.2V, f = 50Hz~20kHz, THD = 1%, R_L = 4Ω)
- Low distortion ratio
 - : THD = 0.015% (typ.)
(V_{CC} = 13.2V, f = 1kHz, P_{OUT} = 4W, R_L = 4Ω)
- Built-in stand-by function (with pin(1) set at high, power is turned on)
- Built-in output short or over voltage detection circuit, output to V_{CC} and output to GND short.
(Pin(8): Open collector)
- Built-in junction temperature detection circuit. (Pin(2): Open collector)
- Built-in various protection circuits
 - Thermal shut down, Over voltage
 - Output to GND short
 - Output to V_{CC} short
 - Output to Output short
- Operating supply voltage: V_{CC} (opr) = 9~18V

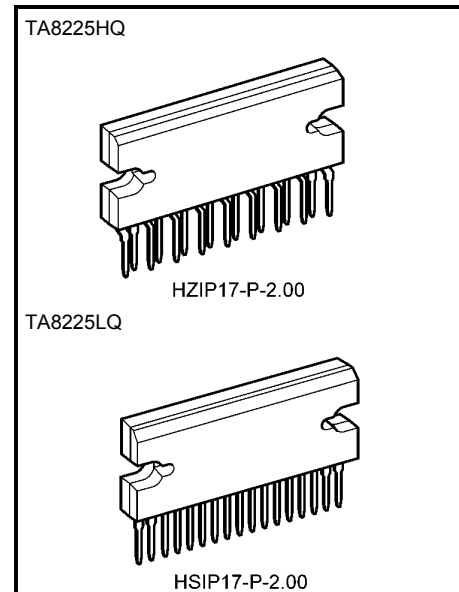

Weight
 HZIP17-P-2.00: 9.8g (typ.)
 HSIP17-P-2.00: 9.8g (typ.)

Block Diagram

TA8225HQ/LQ (G_V = 40dB)

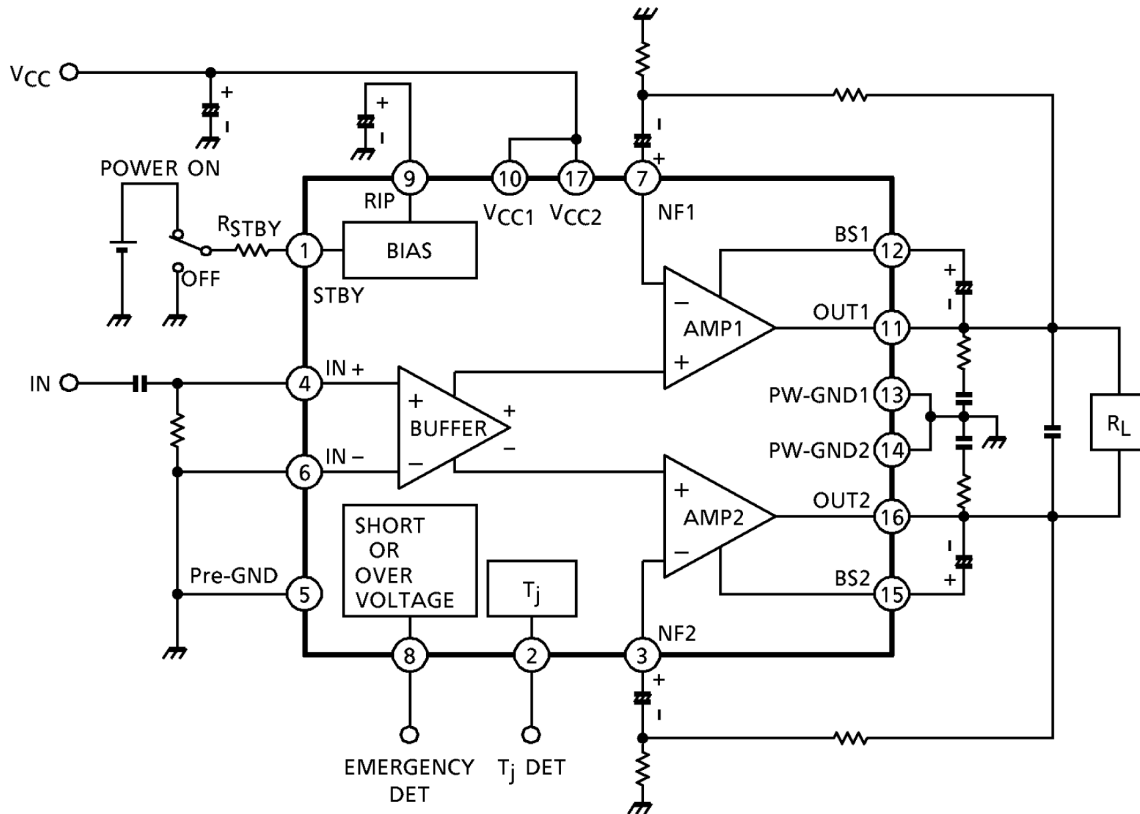

Caution For Use And Method Of Application

1. Voltage gain adjustment

Voltage gain G_V of this IC is decided by the external feedback resistors R_{f1} and R_{f2}. Gain fluctuation by temperature can be made smaller than they are housed in IC. Voltage gain G_V is decided by the following expression:

$$\text{If } R_0 = 20\text{k}\Omega \gg R_{f1} > R_{f2} \quad G_V \doteq 20 \log \frac{R_{f1} + R_{f2}}{R_{f2}} + 6 \text{ (dB)}$$

$$\text{If } R_0 = 20\text{k}\Omega > R_{f1} > R_{f2} \quad G_V \doteq 20 \log \frac{(R_0 // R_{f1}) + R_{f2}}{R_{f2}} + 6 \text{ (dB)}$$

If R_{f1} and R_{f2} are made small, the following problems may be caused:

- (1) When output short is released, output DC voltage is not restored.
- (2) Fluctuation of output DC voltage by current I in (Fig.1).

If voltage gain is made small excessively, oscillation may be taken place and therefore, this IC shall be used at G_V = 34dB or above.

2. Preventive measure against oscillation

For preventing the oscillation, it is advisable to use C₄, the condenser of polyester film having small characteristic fluctuation of the temperature and the frequency.

The condenser (C₆) between input and GND is effective for preventing oscillation which is generated with feedback signal from an output stage.

The resistance R to be series applied to C₄ is effective for phase correction of high frequency, and improves the oscillation allowance.

Since the oscillation allowance is varied according to the causes described below, perform the temperature test to check the oscillation allowance.

- (1) Voltage gain to be used (GV setting)
- (2) Capacity value of condenser
- (3) Kind of condenser
- (4) Layout of printed board

In case of its use with the voltage gain GV reduced or with the feedback amount increased, care must be taken because the phase-inversion is caused by the high frequency resulting in making the oscillation liable generated.

3. Pop noise

A pop noise generated when the power source is turned on depends on rise times of the in-phase side output ((11)pin) and the negative-phase side output ((16)pin), that is, output offset voltage.

The following two points may be pointed out as causes for generation the output offset voltage:

- (1) In-phase and negative-phase NF capacitor charging times
- (2) Input offset voltage

Especially, the factor (2) relates to the pop noise level.

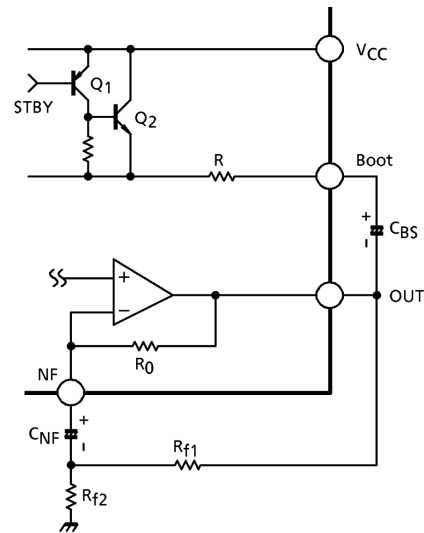

(Fig.2)

(1) In-phase and negative phase NF capacitor charging time

In (Fig.2), when the power source is turned on, Q1 and Q2 are turned on, and NF capacitors are charged in the route of $V_{CC} \rightarrow Q_2 \rightarrow R \rightarrow \text{boot} \rightarrow \text{CBS} \rightarrow \text{out} \rightarrow R_0 \rightarrow C_{NF}$. For instance, if the capacity of an in-phase capacitor is not properly paired with that a negative-phase capacitor, output offset voltage = pop noise is produced because a charging time of NF capacitor differs between the in-phase and negative-phase outputs.

Therefore, to suppress the pop noise it is necessary to properly pair the in-phase and negative-phase NF capacitors. Output and NF DC voltage waveforms by the pairing of NF capacitors: C_{NF} are shown in (Fig.3) and (Fig.4).

Further, voltage waveforms are shown when the power source was turned on, under the following conditions:

$V_{CC} = 13.2V$, $R_L = 4\Omega$, $T_a = 25^\circ C$, and input shot-circuit.

Output DC voltage V_{OUT} : (2V / div, 200ms / div)

NF DC voltage V_{NF} : (1V / div, 200ms / div)

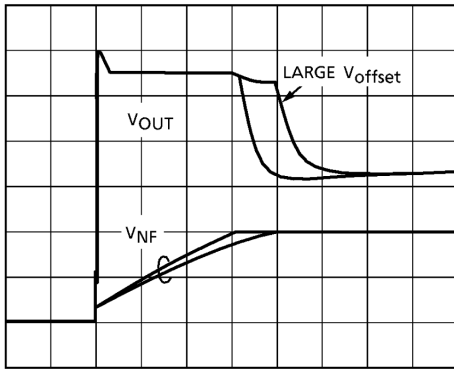

LARGE V_{offset}

(When C_{NF} are improperly paired)

(Fig.3)

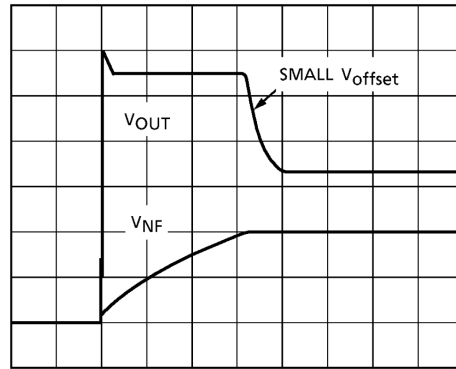

SMALL V_{offset}

(When C_{NF} are properly paired)

(Fig.4)

(2) Input offset voltage

Input offset voltage is increased by as many times as a gain and appears as output offset voltage. Input offset voltage is affected by an external resistor in addition to properness of pair of capacitor in IC. An example of a general application circuit is shown in (Fig.5). In this case, input to the differential amplifier composing the buffer amplifier is decided to be $30k\Omega + 1.1k\Omega = 31.1k\Omega$ at the in (+) side and $1.1k\Omega$ at the in (-) side. Therefore a rising difference of about 30 times between the in (+) side and the in (-) side. So, to fit input offset voltages, it is possible to suppress the input offset voltage by adjusting it to $31.1k\Omega$ both at the in (+) and in (-) sides according to the application example shown in (Fig.6). As input coupling capacitors are used in actual set, the circuit shown in (Fig.7) is considered. In this case, it is necessary to take the utmost care of proper pair of $C_{IN (+)}$ and $C_{IN (-)}$.

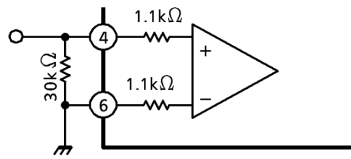

(Fig.5)

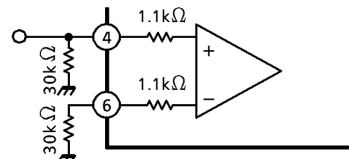

(Fig.6)

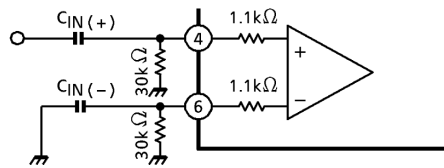

(Fig.7)

Pop noise level affected by input offset voltage shall be checked on an actually mounted set.

4. Junction temperature detecting pin(2)

Using temperature characteristic of a band gap circuit and in proportion to junction temperature, pin(2) DC voltage: V_2 rises at about $\pm 10mV / ^\circ C$ temperature characteristic. So, the relation between V_2 at $T_j = 25^\circ C$ and $V_2 \chi$ at $T_j = \chi^\circ C$ is decided by the following expression:

$$T_j (\chi^\circ C) = \frac{V_2 \chi - V_2 (25^\circ C)}{10mV / ^\circ C} + 25^\circ C$$

In deciding a heat sink suze, a junction temperature can be easily made clear by measuring voltage at this pin while a backside temperature of IC was so far measured using a thermocouple type thermometer.

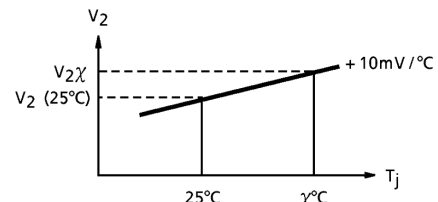

(Fig.8)

5. Output-VCC short, output-GND short and over voltage detecting pin(8)

In case of such abnormalities as output-VCC short, output-GND short, overvoltage (Fig.9), it is possible to inform the abnormal state to the outside by turning a NPN transistor is turned on.

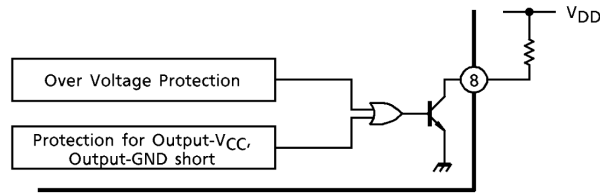

(Fig.9)

It is possible to improve the reliability of not only power IC but also an entire equipment by (1) display by LED and LCD and (2) by turning the power supply relay off.

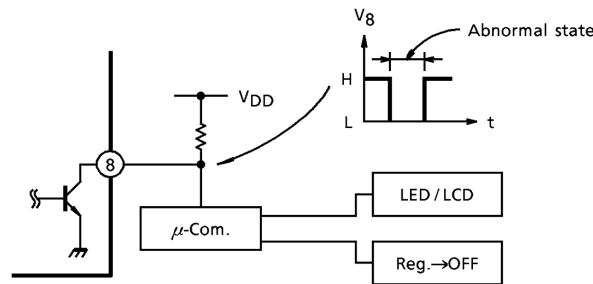

(Fig.10)

6. Stand-by SW function

By means of controlling pin(1) (stand-by terminal) to high and low, the power supply can be set to on and off. The threshold voltage of pin(1) is set at about $3V_{BE} \approx 2.1V$ (typ.), and the power supply current is about $1\mu A$ (typ.) at the stand-by state.

Control voltage of (1)pin: V (SB)

Stand-By	Power	V (SB) (V)
On	Off	0~2
Off	On	$3 \sim V_{CC}$

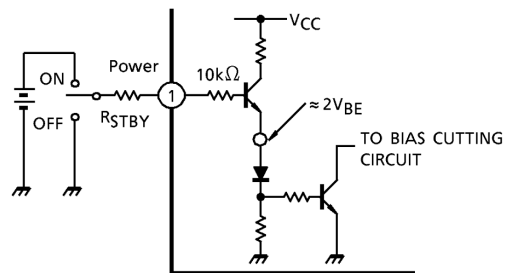

With pin ① set to high, power is turned ON.

(Fig.11)

<Caution>

Must be set the control voltage value less than VCC when the stand-by terminal (pin(1)) is applied. In this case, we recommended the series connecting resistance for current limit: RSTBY (100kΩ~1kΩ to pin(1).)

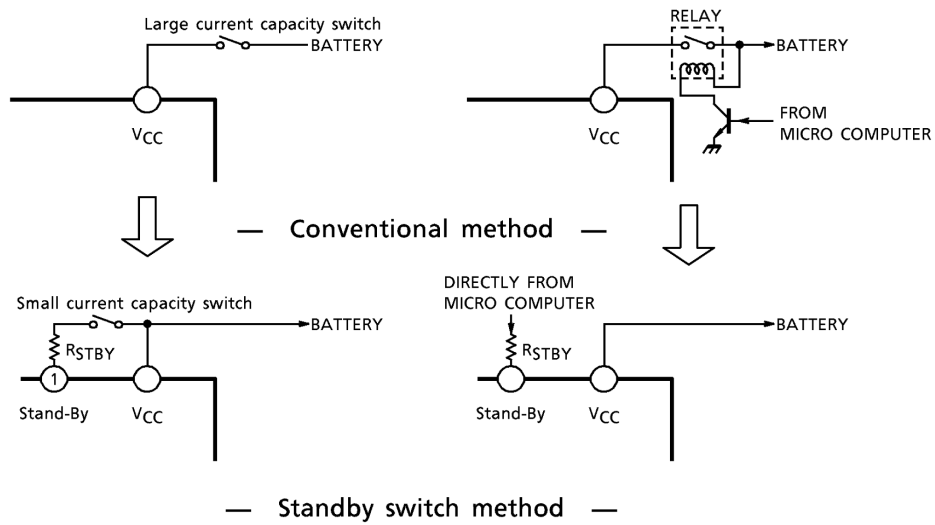

Absolute Maximum Ratings (Ta = 25°C)

Characteristic	Symbol	Rating	Unit
Peak supply voltage (0.2s)	V _{CC} (surge)	50	V
DC supply voltage	V _{CC} (DC)	25	V
Operating supply voltage	V _{CC} (opr)	18	V
Output current (peak)	I _O (peak)	9	A
Power dissipation	P _D	50	W
Operating temperature	T _{opr}	-30~85	°C
Storage temperature	T _{stg}	-55~150	°C

Electrical Characteristics

(unless otherwise specified, $V_{CC} = 13.2V$, $R_L = 4\Omega$, $R_g = 600\Omega$, $f = 1kHz$, $T_a = 25^\circ C$)

Characteristic	Symbol	Test Circuit	Test Condition	Min.	Typ.	Max.	Unit
Quiescent current	I_{CCQ}	—	$V_{IN} = 0$	—	150	250	mA
Output power	$P_{OUT(1)}$	—	$V_{CC} = 14.4V$, THD = 10%, $R_L = 2\Omega$	—	45	—	W
	$P_{OUT(2)}$	—	THD = 10%, $R_L = 2\Omega$	33	40	—	W
	$P_{OUT(3)}$	—	THD = 10%	20	24	—	W
	$P_{OUT(4)}$	—	THD = 1%, $f = 50Hz \sim 20kHz$	—	18	—	W
Total harmonic distortion	THD	—	$P_{OUT} = 4W$	—	0.015	0.07	%
Voltage gain	G_V	—	$V_{IN} = 10mV_{rms}$	38.5	40	41.5	dB
Output noise voltage	$V_{NO(1)}$	—	$R_g = 0$, DIN45405 Noise filter	—	0.26	—	mV_{rms}
	$V_{NO(2)}$	—	$R_g = 0$, BW = 20Hz~20kHz	—	0.23	0.5	mV_{rms}
Ripple rejection ratio	R.R.	—	$f = 100Hz$, $V_{ripple} = 0.775V_{rms}$ (0dBm)	50	60	—	dB
Output offset voltage	V_{offset}	—	$V_{IN} = 0$	-100	0	100	mV
Current at stand-by state	I_{SB}	—	—	—	1	30	μA

Test Circuit

TA8225HQ/LQ ($G_V = 40dB$)

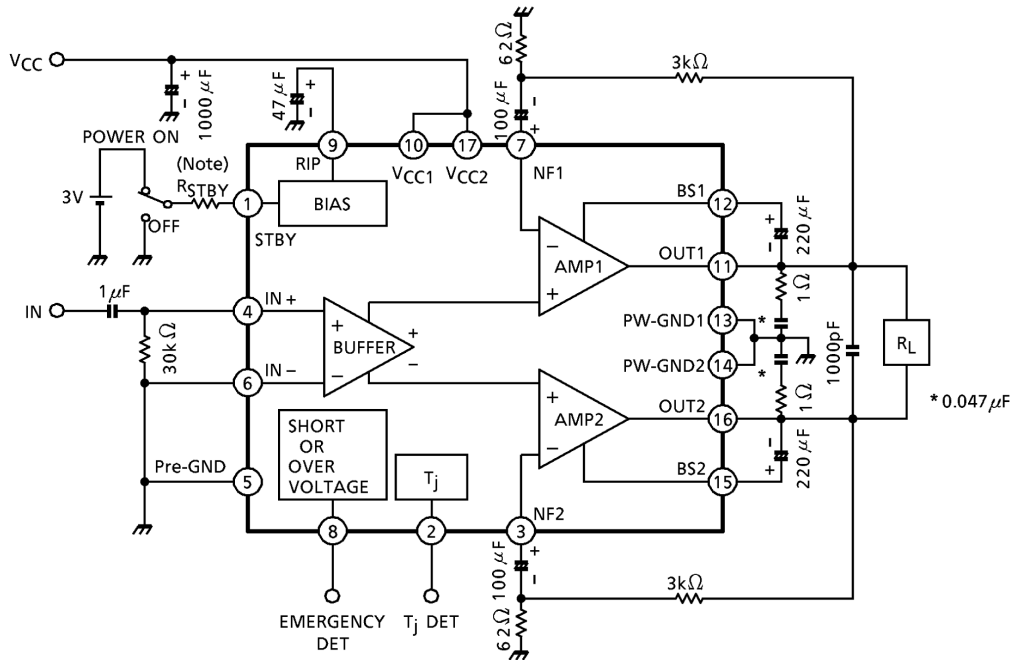

(Note) The purpose of R_{STBY} is current limiting resistance.

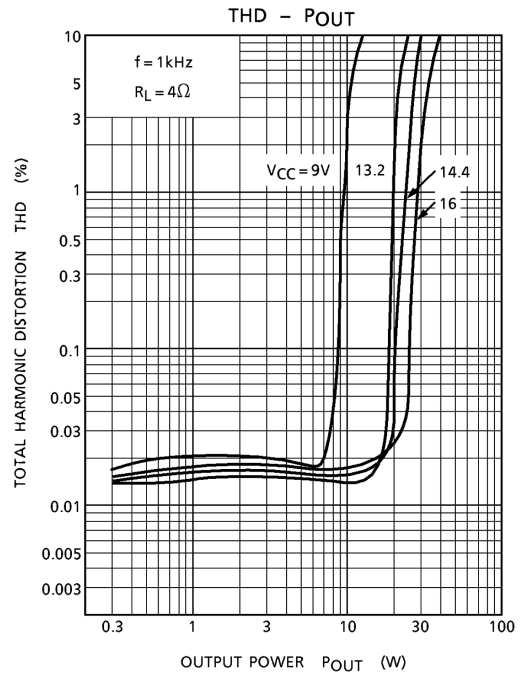
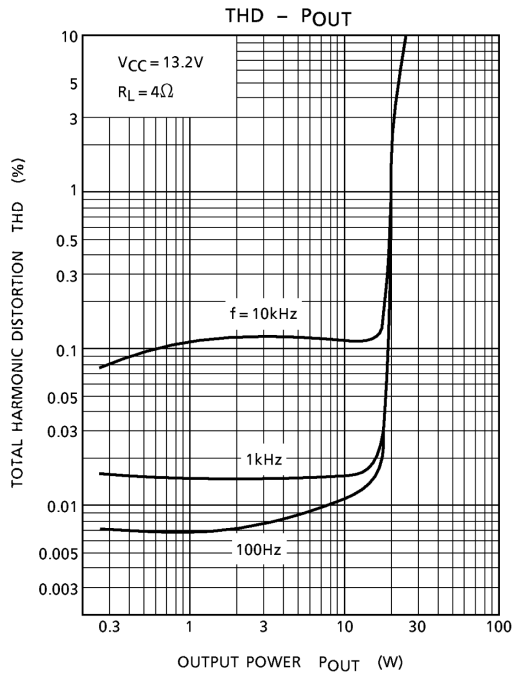
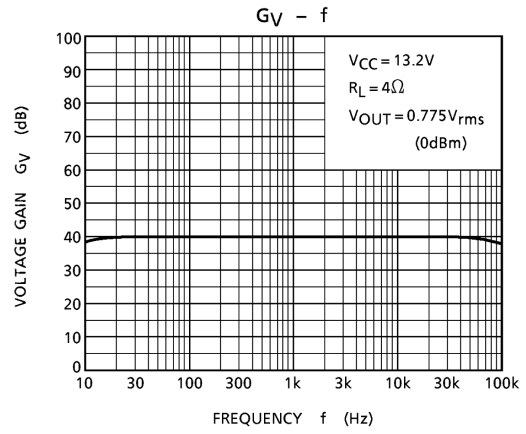
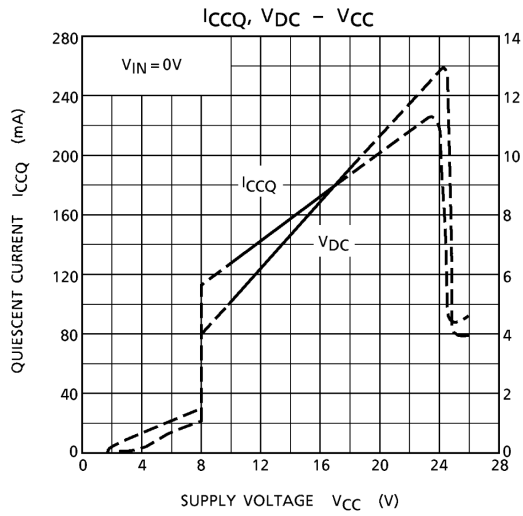

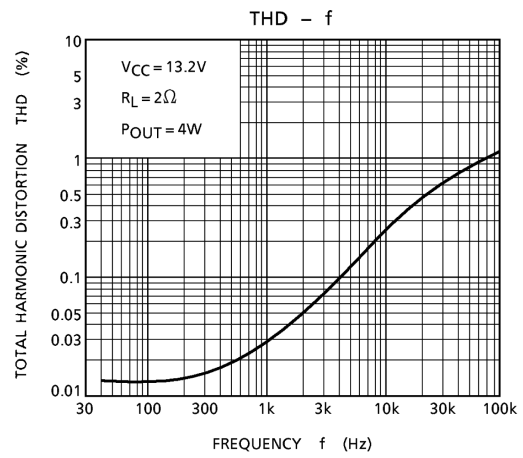
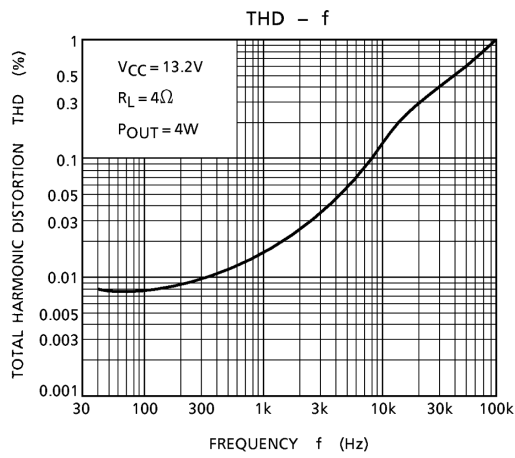
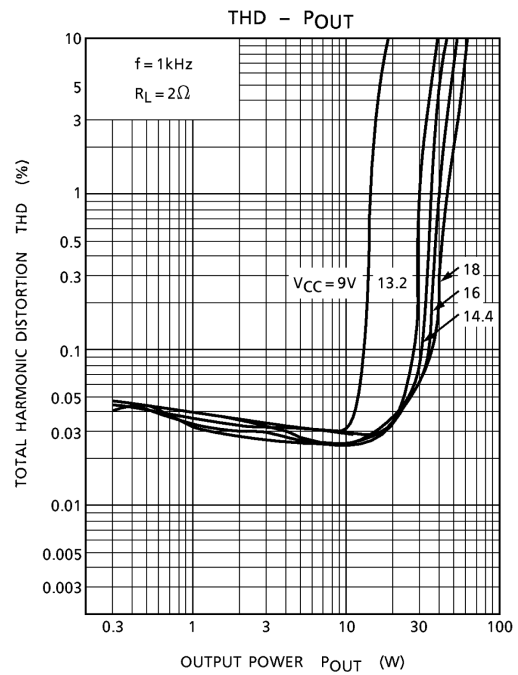
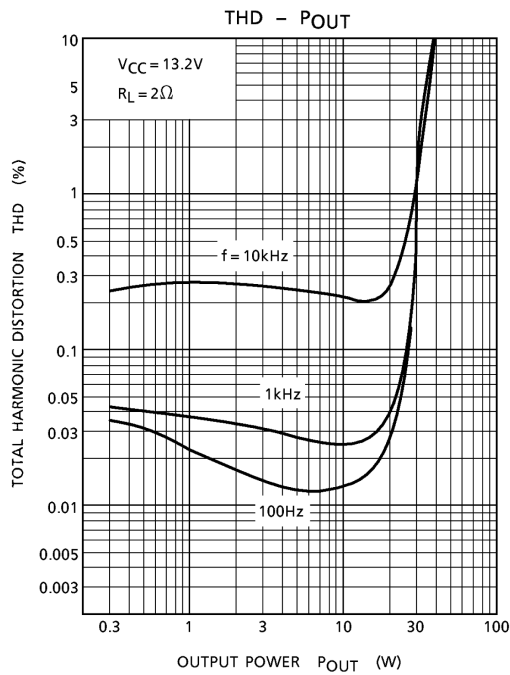

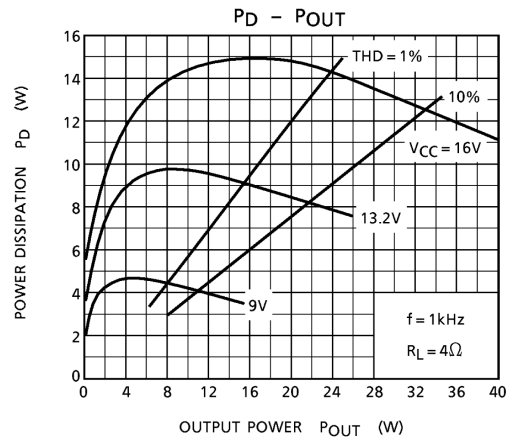
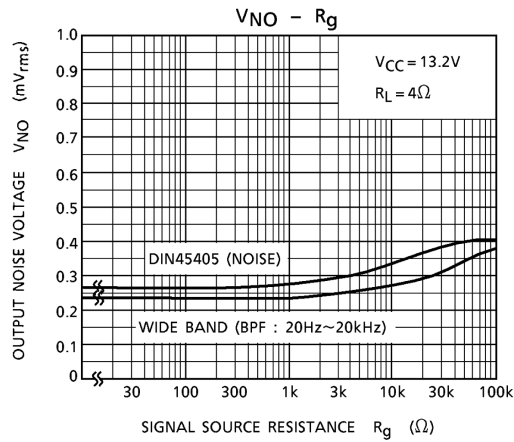
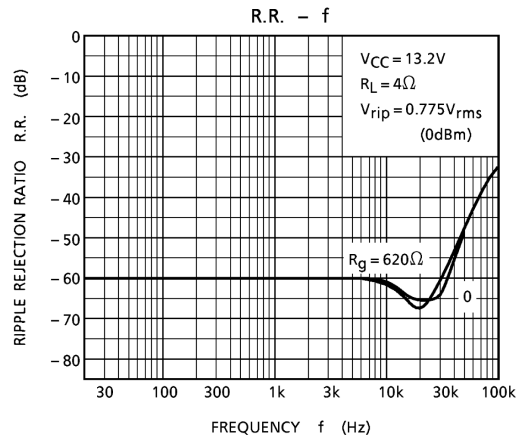
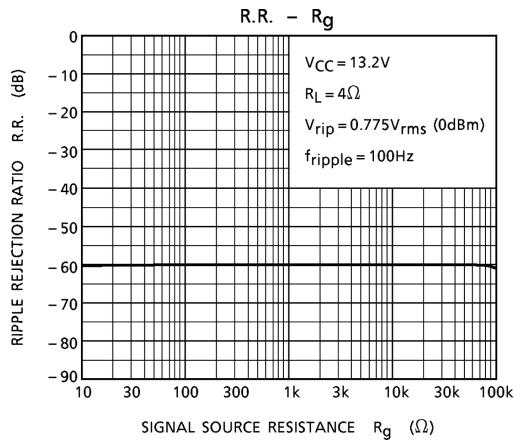
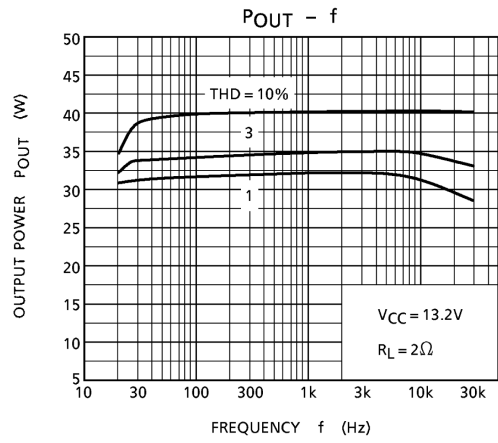
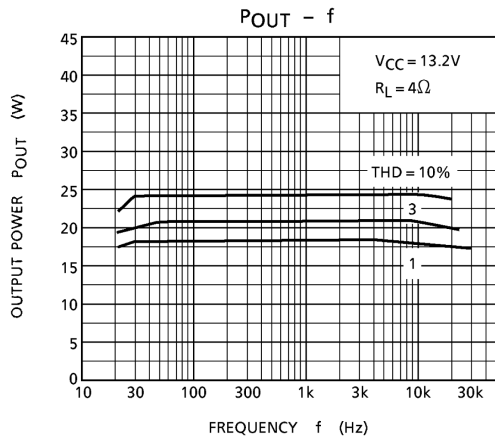

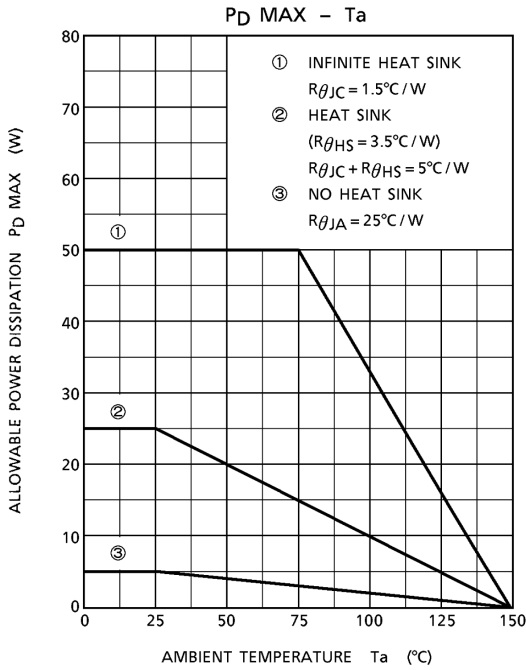
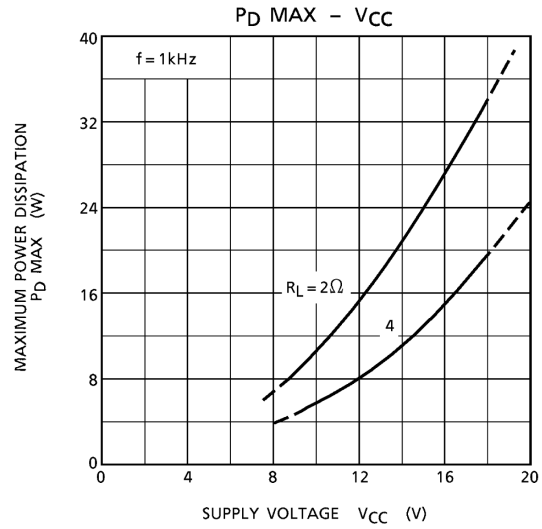
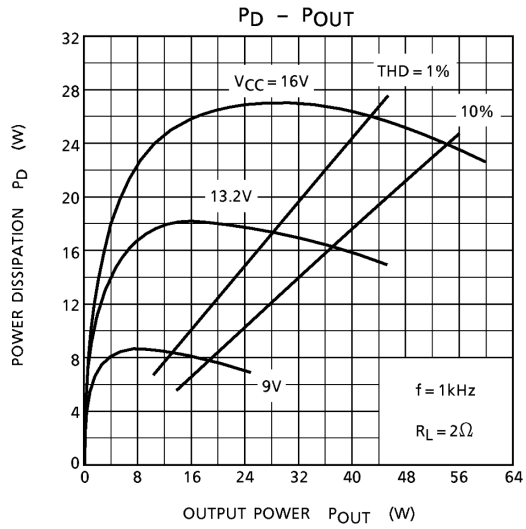

Package Dimensions

HZIP17-P-2.00

Unit : mm

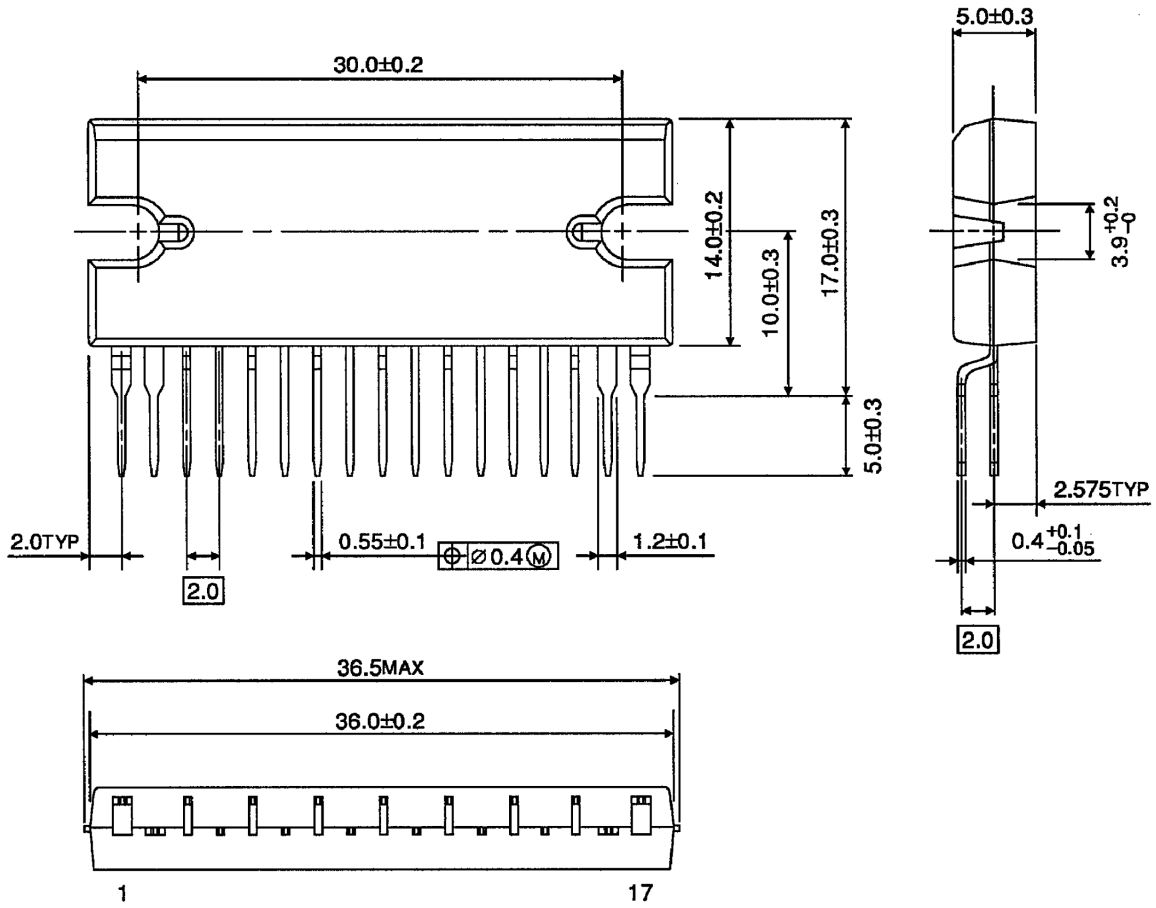

Weight: 9.8g (typ.)

Package Dimensions

HSIP17-P-2.00

Unit : mm

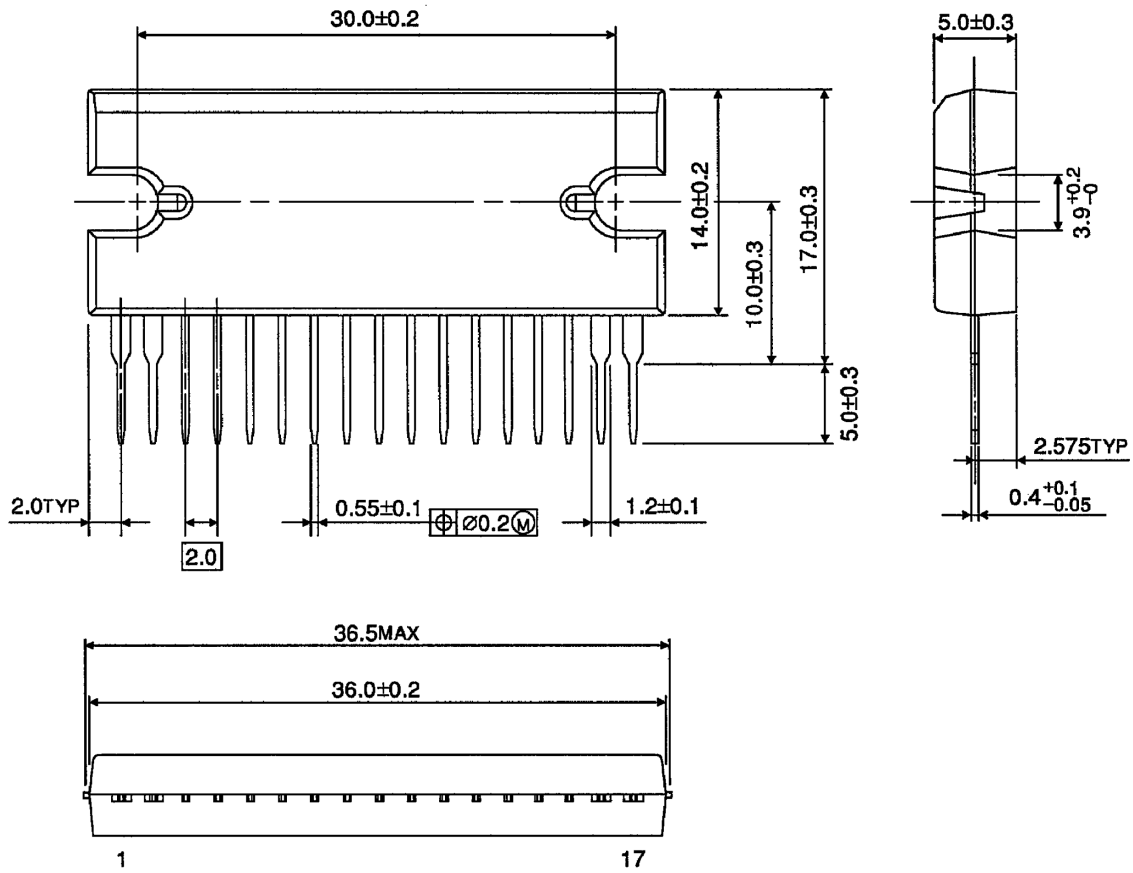

Weight: 9.8g (typ.)

- Use an appropriate power supply fuse to ensure that a large current does not continuously flow in case of over current and/or IC failure. The IC will fully break down when used under conditions that exceed its absolute maximum ratings, when the wiring is routed improperly or when an abnormal pulse noise occurs from the wiring or load, causing a large current to continuously flow and the breakdown can lead smoke or ignition. To minimize the effects of the flow of a large current in case of breakdown, appropriate settings, such as fuse capacity, fusing time and insertion circuit location, are required.
- If your design includes an inductive load such as a motor coil, incorporate a protection circuit into the design to prevent device malfunction or breakdown caused by the current resulting from the inrush current at power ON or the negative current resulting from the back electromotive force at power OFF. For details on how to connect a protection circuit such as a current limiting resistor or back electromotive force adsorption diode, refer to individual IC datasheets or the IC databook. IC breakdown may cause injury, smoke or ignition.
- Use a stable power supply with ICs with built-in protection functions. If the power supply is unstable, the protection function may not operate, causing IC breakdown. IC breakdown may cause injury, smoke or ignition.
- Carefully select external components (such as inputs and negative feedback capacitors) and load components (such as speakers), for example, power amp and regulator. If there is a large amount of leakage current such as input or negative feedback condenser, the IC output DC voltage will increase. If this output voltage is connected to a speaker with low input withstand voltage, overcurrent or IC failure can cause smoke or ignition. (The over current can cause smoke or ignition from the IC itself.) In particular, please pay attention when using a Bridge Tied Load (BTL) connection type IC that inputs output DC voltage to a speaker directly.
- Over current Protection Circuit
Over current protection circuits (referred to as current limiter circuits) do not necessarily protect ICs under all circumstances. If the Over current protection circuits operate against the over current, clear the over current status immediately. Depending on the method of use and usage conditions, such as exceeding absolute maximum ratings can cause the over current protection circuit to not operate properly or IC breakdown before operation. In addition, depending on the method of use and usage conditions, if over current continues to flow for a long time after operation, the IC may generate heat resulting in breakdown.
- Thermal Shutdown Circuit
Thermal shutdown circuits do not necessarily protect ICs under all circumstances. If the Thermal shutdown circuits operate against the over temperature, clear the heat generation status immediately. Depending on the method of use and usage conditions, such as exceeding absolute maximum ratings can cause the thermal shutdown circuit to not operate properly or IC breakdown before operation.
- Heat Radiation Design
When using an IC with large current flow such as power amp, regulator or driver, please design the device so that heat is appropriately radiated, not to exceed the specified junction temperature (T_j) at any time and condition. These ICs generate heat even during normal use. An inadequate IC heat radiation design can lead to decrease in IC life, deterioration of IC characteristics or IC breakdown. In addition, please design the device taking into considerate the effect of IC heat radiation with peripheral components.
- Installation to Heat Sink
Please install the power IC to the heat sink not to apply excessive mechanical stress to the IC. Excessive mechanical stress can lead to package cracks, resulting in a reduction in reliability or breakdown of internal IC chip. In addition, depending on the IC, the use of silicon rubber may be prohibited. Check whether the use of silicon rubber is prohibited for the IC you intend to use, or not. For details of power IC heat radiation design and heat sink installation, refer to individual technical datasheets or IC databooks.

RESTRICTIONS ON PRODUCT USE

060116EBF

- The information contained herein is subject to change without notice. 021023_D
- TOSHIBA is continually working to improve the quality and reliability of its products. Nevertheless, semiconductor devices in general can malfunction or fail due to their inherent electrical sensitivity and vulnerability to physical stress. It is the responsibility of the buyer, when utilizing TOSHIBA products, to comply with the standards of safety in making a safe design for the entire system, and to avoid situations in which a malfunction or failure of such TOSHIBA products could cause loss of human life, bodily injury or damage to property.
In developing your designs, please ensure that TOSHIBA products are used within specified operating ranges as set forth in the most recent TOSHIBA products specifications. Also, please keep in mind the precautions and conditions set forth in the "Handling Guide for Semiconductor Devices," or "TOSHIBA Semiconductor Reliability Handbook" etc. 021023_A
- The TOSHIBA products listed in this document are intended for usage in general electronics applications (computer, personal equipment, office equipment, measuring equipment, industrial robotics, domestic appliances, etc.). These TOSHIBA products are neither intended nor warranted for usage in equipment that requires extraordinarily high quality and/or reliability or a malfunction or failure of which may cause loss of human life or bodily injury ("Unintended Usage"). Unintended Usage include atomic energy control instruments, airplane or spaceship instruments, transportation instruments, traffic signal instruments, combustion control instruments, medical instruments, all types of safety devices, etc. Unintended Usage of TOSHIBA products listed in this document shall be made at the customer's own risk. 021023_B
- The products described in this document shall not be used or embedded to any downstream products of which manufacture, use and/or sale are prohibited under any applicable laws and regulations. 060106_Q
- The information contained herein is presented only as a guide for the applications of our products. No responsibility is assumed by TOSHIBA for any infringements of patents or other rights of the third parties which may result from its use. No license is granted by implication or otherwise under any patent or patent rights of TOSHIBA or others. 021023_C
- The products described in this document are subject to the foreign exchange and foreign trade laws. 021023_E
- This product generates heat during normal operation. However, substandard performance or malfunction may cause the product and its peripherals to reach abnormally high temperatures.
The product is often the final stage (the external output stage) of a circuit. Substandard performance or malfunction of the destination device to which the circuit supplies output may cause damage to the circuit or to the product. 030619_R

About solderability, following conditions were confirmed

- Solderability
 - (1) Use of Sn-37Pb solder Bath
 - solder bath temperature = 230°C
 - dipping time = 5 seconds
 - the number of times = once
 - use of R-type flux
 - (2) Use of Sn-3.0Ag-0.5Cu solder Bath
 - solder bath temperature = 245°C
 - dipping time = 5 seconds
 - the number of times = once
 - use of R-type flux