

The Si825x family of programmable digital power controllers provides closed-loop feedback control, system protection and power management functions for switch mode power systems. The novel Si825x architecture combines a dedicated DSP-based control loop processor with an in-system programmable system management processor. This architecture guarantees the control loop is updated at 10 MHz, regardless of firmware size and complexity for the fastest possible control response. Firmware can change all control parameters on the fly (loop gain, compensation, timing, etc.) enabling the system to quickly and intelligently adapt to changing operating conditions, such as loading and unloading transients. The Si825x family is supported by a low-cost development kit, which includes a complete real-time firmware kernel with intuitive design tools. Packaged in a tiny 5 x 5 mm 28-pin QFN package or 32-pin LQFP, the Si825x family provides cost-effective control solutions that offer greater levels of performance, controllability, reliability, and flexibility than today's analog-based designs.

Single-Chip, Flash Digital Controller

- Supports isolated and non-isolated applications
- Supports ac/dc, dc/dc and PFC applications
- Enables new system capabilities
 - Adaptive dead-time control
 - Nonlinear control response
 - Efficiency optimization
 - Self diagnostics/status reporting

Dedicated DSP-Based Loop Processor

- Fixed 10 MHz update rate (independent of firmware)
- Differential input ADC
- Loop filter DSP engine
 - PID + 2nd stage low-pass filter
 - Selectable discrete time or SINC 2nd stage low-pass filter
- Highly flexible DPWM with up to 6 output phases
 - Less than 5 ns dithered resolution
- Hardware pulse-by-pulse current limiting with programmable leading-edge blanking

- Programmable hardware over-current protection

50 MIPS Flash System Management Processor

- 16 or 32 kB of Flash
 - Flash can be used as EEPROM
- On-board 2% oscillator
- Self-sequencing, 8-channel 12-bit ADC
 - Supports firmware-programmable safeguards (UVLO, OTP, OVP)
 - Individual hardware limit detectors with vectored interrupts
 - On-board temperature sensor and VREF
- High-speed, programmable general-purpose comparator
- PMBus hardware interface (SMBus)
- Enhanced UART for isolated control data link
- Four 16-bit timers
- 3-Channel PCA for general-purpose timing or additional PWM outputs
- High-current, fully-programmable I/O port lines

Comprehensive, Low-cost Development Kit

- Minimizes learning curve and speeds time-to-market
- Real-time firmware kernel greatly reduces firmware development
- Intuitive compensator design tool
- GUI-based waveform designer/simulator
- System configuration wizards
- Intuitive IDE with real-time debug
 - Standard and on-line debug modes
 - Everything included

Applications

- DC/DC converters
- AC/DC converters
- PFC circuits
- DC motor control

5 x 5 mm 28-pin QFN and 32-pin LQFP Packages 125 °C Maximum Operating Temperature

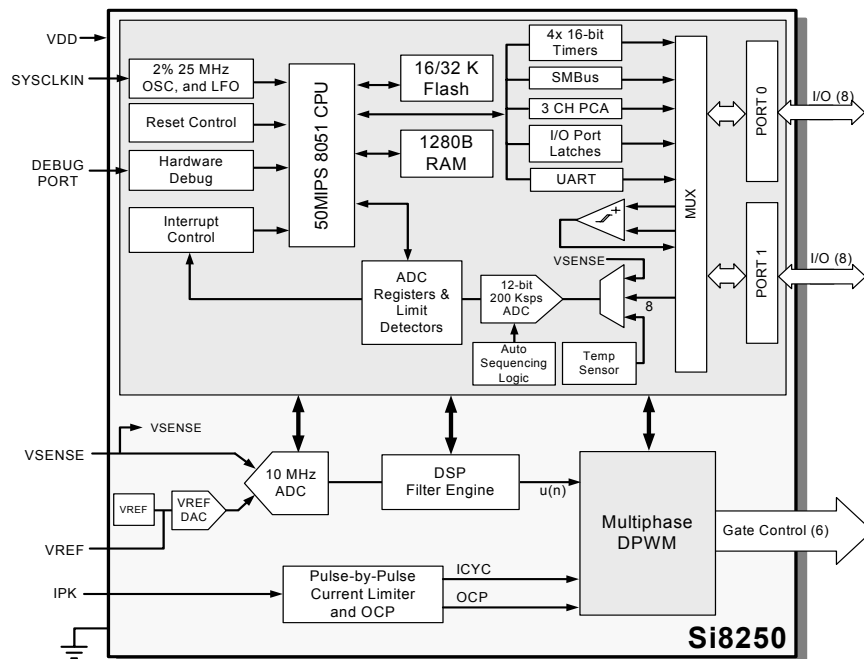

Selected Electrical Specifications

($T_A = -40$ to $+125$ °C, $V_{DD} = 2.5$ V unless otherwise specified)

Parameter	Conditions	Min	Typ	Max	Units
Global Characteristics					
Supply Voltage		2.25	—	2.55	V
Supply Current	All peripherals enabled	—	25	—	mA
	$V_{IN} < V_{UVLO}$	—	200	—	μ A
	Stop mode	—	0.1	—	μ A
Loop Processor Specifications					
DSP Data Path		—	22	—	Bits
Loop ADC Sampling Frequency		—	10	—	MHz
DPWM Resolution	Not dithered	5	—	—	ns
IPK Sense to DPWM Output Delay		—	15	—	ns
System Management Processor Specifications					
Processor Throughput		—	—	50	MIPS
Management ADC Resolution		—	—	12	Bits
Management ADC Sampling Frequency		—	200	—	ksp/s
General Purpose Comparator Response Time	Low power mode, 25 mV Overdrive	—	—	750	ns
	High power mode, 25 mV Overdrive	—	—	40	

Ordering Guide

Part Number	Flash	DPWM Outputs	UART	Comparator	Package	Temperature
Si8250-IM	32 K	6 Φ	Y	Y	QFN28	-40 to 125 °C
Si8250-IQ	32 K	6 Φ	Y	Y	LQFP32	-40 to 125 °C
Si8251-IM	16 K	6 Φ	Y	Y	QFN28	-40 to 125 °C
Si8251-IQ	16 K	6 Φ	Y	Y	LQFP32	-40 to 125 °C
Si8252-IM	16 K	3 Φ	N	N	QFN28	-40 to 125 °C
Si8252-IQ	16 K	3 Φ	N	N	LQFP32	-40 to 125 °C

Package Information (28-pin QFN)

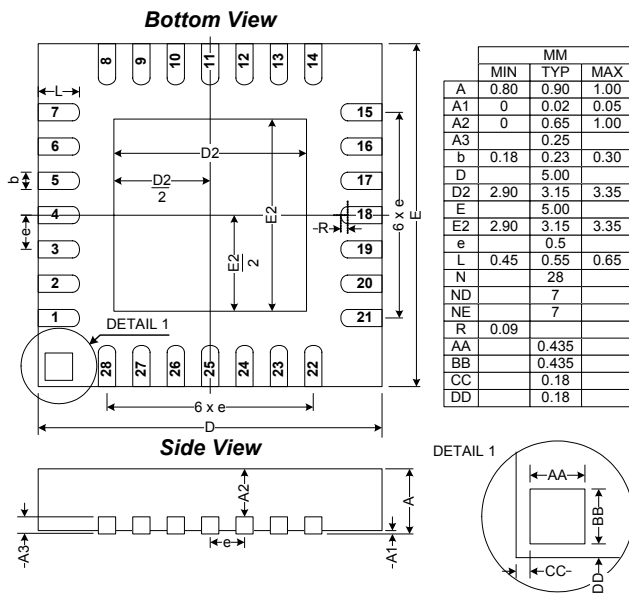

Package Information (32-pin LQFP)

