

ZXGD3103N8 SYNCHRONOUS MOSFET CONTROLLER

Description

The ZXGD3103 is intended to drive MOSFETS configured as ideal diode replacements. The device is comprised of a differential amplifier detector stage and high current driver. The detector monitors the reverse voltage of the MOSFET such that if body diode conduction occurs a positive voltage is applied to the MOSFET's Gate pin.

Once the positive voltage is applied to the Gate the MOSFET switches on allowing reverse current flow. The detectors' output voltage is then proportional to the MOSFET Drain-Source reverse voltage drop and this is applied to the Gate via the driver. This action provides a rapid turn off as current decays.

Features

- Proportional Gate Drive
- Turn-off propagation delay 15ns and turn-off time 20ns.
- Detector threshold voltage ~10mV
- Standby current 5mA
- Suitable for Discontinuous Mode (DCM), Critical Conduction Mode (CrCM) and Continuous Mode (CCM) operation
- 5-15V V_{CC} range

Applications

- Flyback Converters in:
 - Adaptors
 - LCD Monitors
 - Server PSU's
 - Set Top Boxes
 - LCD TV
- Resonant Converters
 - LED TV
 - High power Adaptors
 - Street Lighting
 - ATX psu

Pin out details

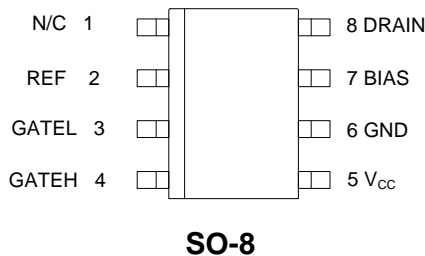

Typical Configuration

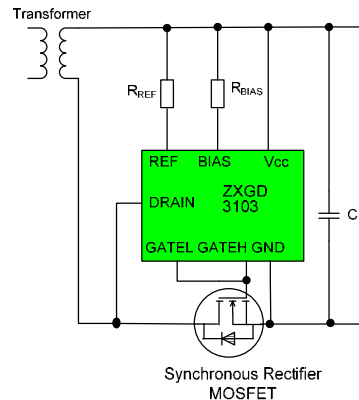

Ordering information

Device	Status	Package	Part Mark	Reel size (inches)	Tape width (mm)	Quantity per reel
ZXGD3103N8TC	Production	SO8	ZXGD3103	13	12	2500

Absolute maximum ratings

Parameter	Symbol	Limit	Unit
Supply voltage ¹	V_{CC}	15	V
Continuous Drain pin voltage ¹	V_D	-3 to 180	V
GATEH and GATEL output Voltage ¹	V_G	-3 to $V_{CC} + 3$	V
Driver peak source current	I_{SOURCE}	2.5	A
Driver peak sink current	I_{SINK}	6	A
Reference current	I_{REF}	25	mA
Bias voltage	V_{BIAS}	V_{CC}	V
Bias current	I_{BIAS}	100	mA
Power dissipation at $T_A = 25^\circ\text{C}$	P_D	490	mW
Operating junction temperature	T_j	-40 to +150	$^\circ\text{C}$
Storage temperature	T_{stg}	-50 to +150	$^\circ\text{C}$

Notes: 1. All voltages are relative to GND pin.

Thermal resistance

Parameter	Symbol	Value	Unit
Junction to ambient (a)	$R_{\theta JA}$	255	$^\circ\text{C}/\text{W}$
Junction to lead (b)	$R_{\theta IA}$	120	$^\circ\text{C}/\text{W}$

Notes: a. Mounted on minimum 1oz weight copper on FR4 PCB in still air conditions.
b. Output Drivers - Junction to solder point at end of the lead 5 and 6

ESD Rating

Model	Rating	Unit
Human Body	4000	V
Machine	400	V

Schematic Symbol and Pin Out Details

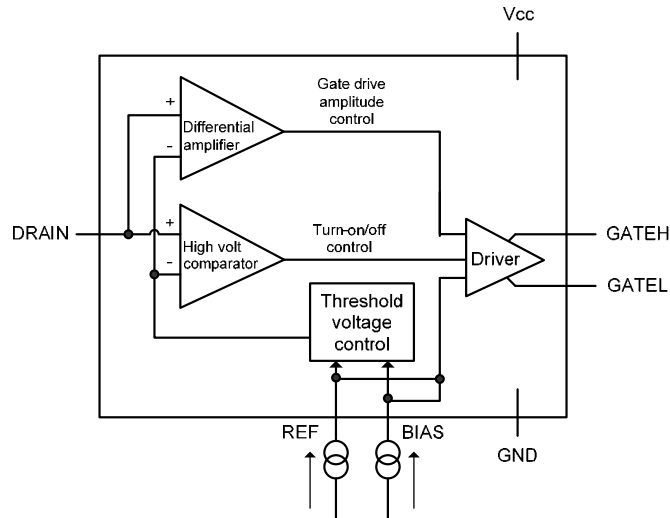

Pin No.	Name	Description and function
1	NC	No Internal connection
2	REF	Reference This pin is connected to V_{CC} via resistor, R_{REF}
3	GATEL	Gate turn off This pin sinks current, I_{SINK} , from the synchronous MOSFET Gate.
4	GATEH	Gate turn on This pin sources current, I_{SOURCE} , to the synchronous MOSFET Gate.
5	V_{CC}	Power Supply This is the supply pin. It is recommended to decouple this point to ground closely with a ceramic capacitor.
6	GND	Ground This is the ground reference point. Connect to the synchronous MOSFET Source terminal.
7	BIAS	Bias This pin is connected to V_{CC} via resistor, R_{BIAS} .
8	DRAIN	Drain connection This pin connects directly to the synchronous MOSFET Drain terminal.

Typical Characteristics

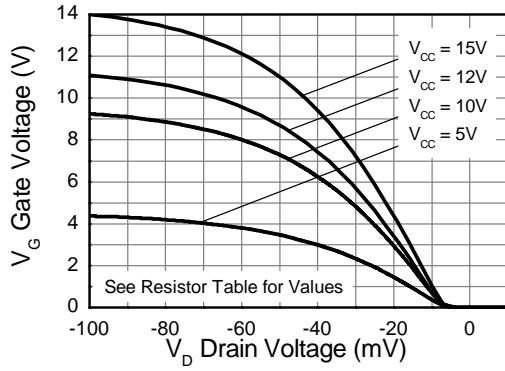

Transfer Characteristic

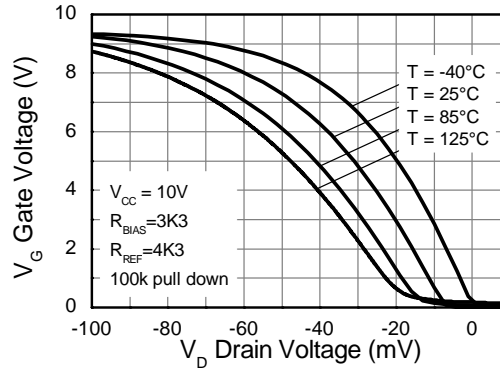

Transfer Characteristic

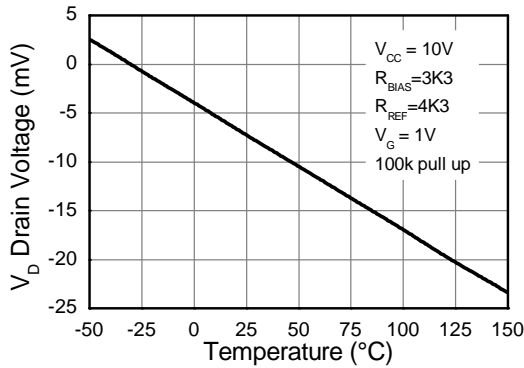

Drain Sense Voltage vs Temperature

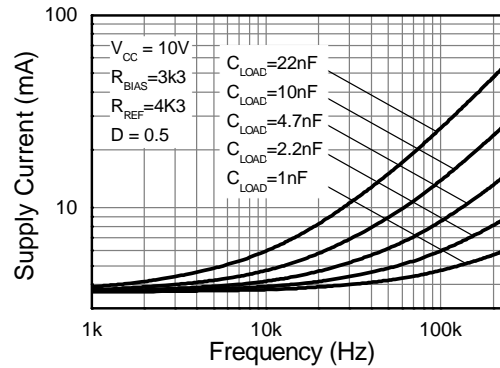

Supply Current vs Frequency

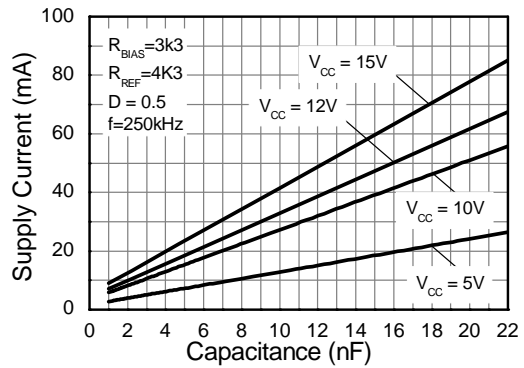

Supply Current vs Capacitive Load

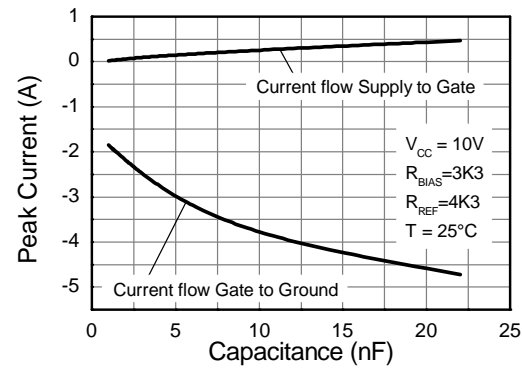

Gate Current vs Capacitive Load

Typical Characteristics

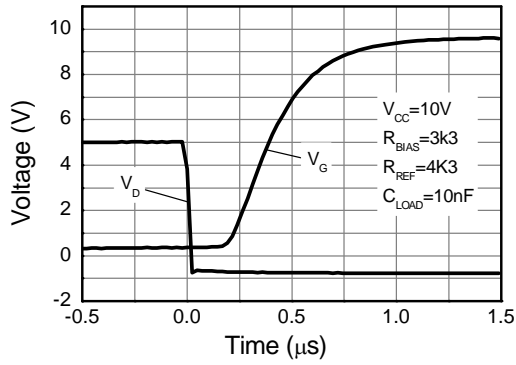

Switch On Speed

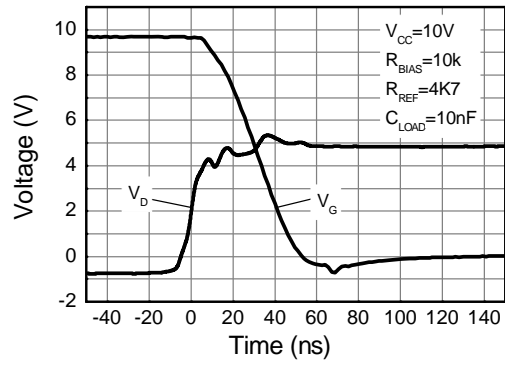

Switch Off Speed

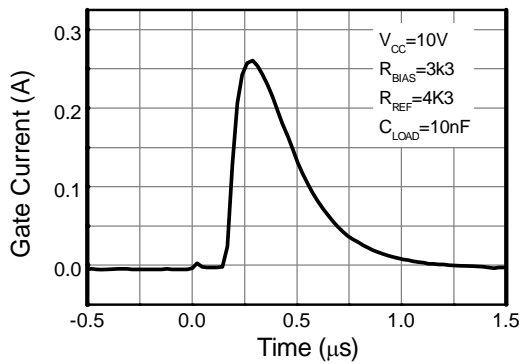

Gate Drive On Current

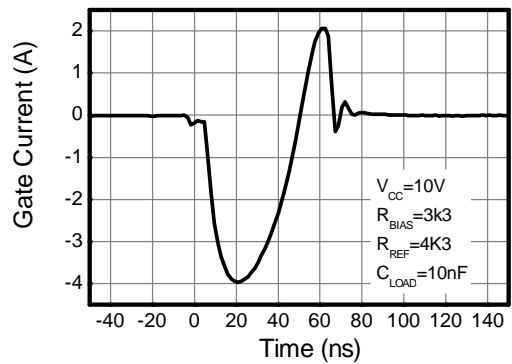

Gate Drive Off Current

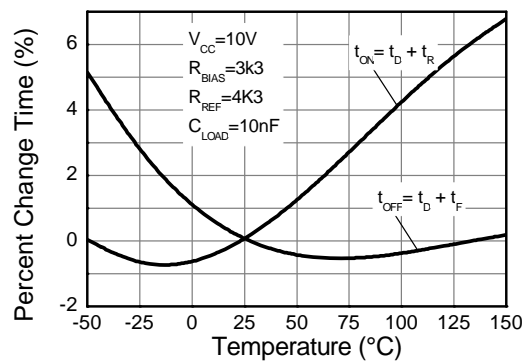

Switching vs Temperature

Application information

The purpose of the ZXGD3103 is to drive a MOSFET as a low- V_F Schottky diode replacement in offline power converters. When combined with a low $R_{DS(ON)}$ MOSFET, it can yield significant power efficiency improvement, whilst maintaining design simplicity and incurring minimal component count. Figure 1 and 2 show typical configuration of ZXGD3103 for synchronous rectification in a Flyback and a multiple output resonant converter.

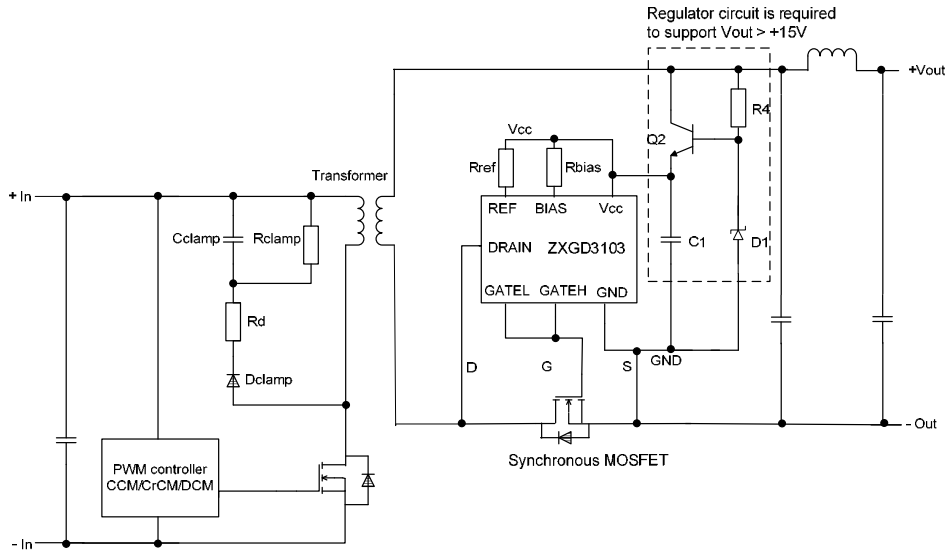

Figure 1. Example connections in Flyback supply

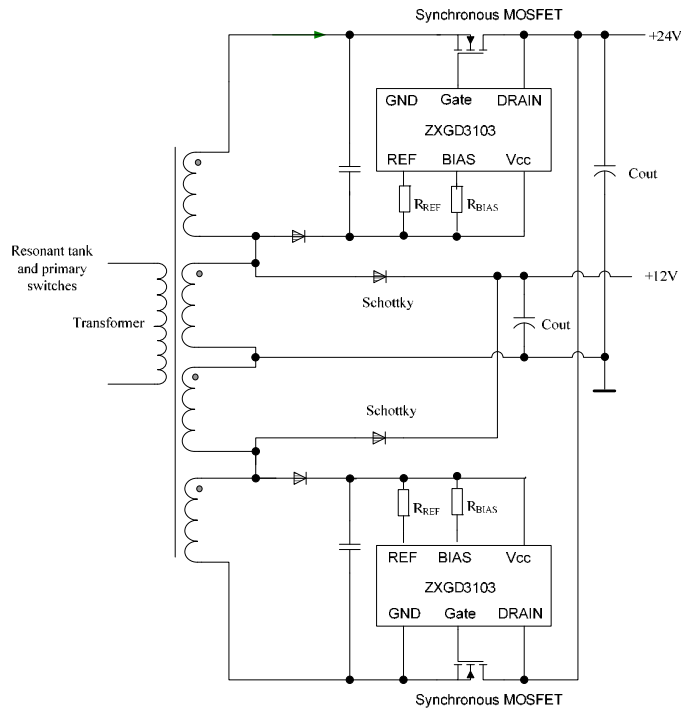

Figure 2. Example connections in LLC supply

Descriptions of the normal operation

The operation of the device is described step-by-step with reference to the timing diagram in Figure 3.

1. The detector monitors the MOSFET Drain-Source voltage.
2. When, due to transformer action, the MOSFET body diode is forced to conduct there is approximately -0.8V on the Drain pin.
3. The detector outputs a positive voltage with respect to ground, this voltage is then fed to the MOSFET driver stage and current is sourced out of the GATE pin.
4. The controller goes into proportional gate drive control — the GATE output voltage is proportional to the on-resistance-induced Drain-Source voltage drop across the MOSFET. Proportional gate drive ensures that MOSFET conducts for majority of the conduction cycle and minimizes body diode conduction time.
5. As the Drain current decays linearly toward zero, proportional gate drive control reduces the Gate voltage so the MOSFET can be turned off rapidly at zero current crossing. The GATE voltage is removed when the Drain-Source voltage crosses the detection threshold voltage to minimize reverse current flow.
6. At zero Drain current, the controller GATE output voltage is pulled low to $V_{G(off)}$ to ensure that the MOSFET is off.

Figure 4 shows typical operating waveforms for ZXGD3103 driving a MOSFET with $Q_{g(TOT)} = 82nC$ in a Flyback converter operating in critical conduction mode.

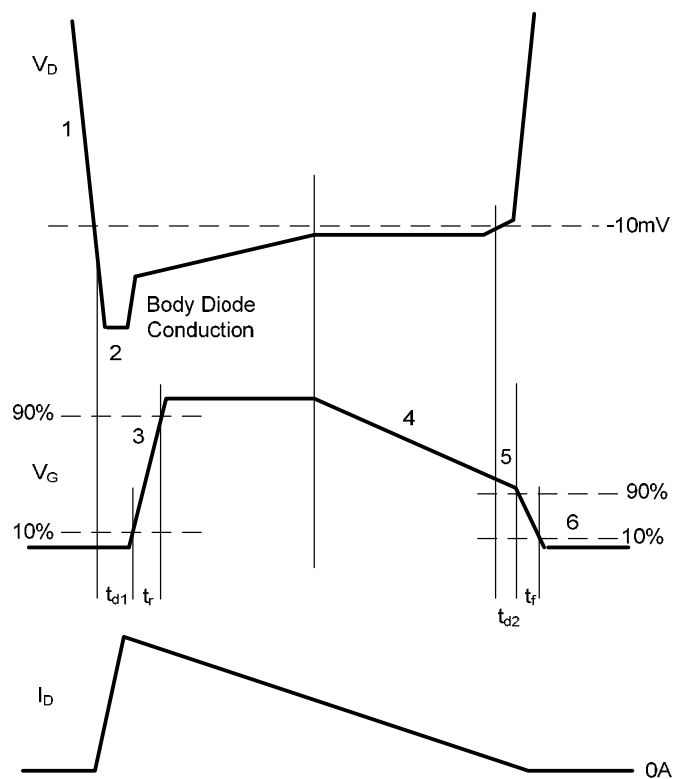

Figure 3. Timing diagram for a critical conduction mode Flyback converter

Typical waveforms

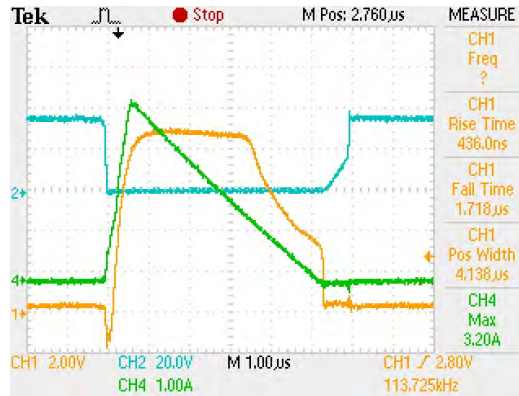

Fig 4a: Critical conduction mode

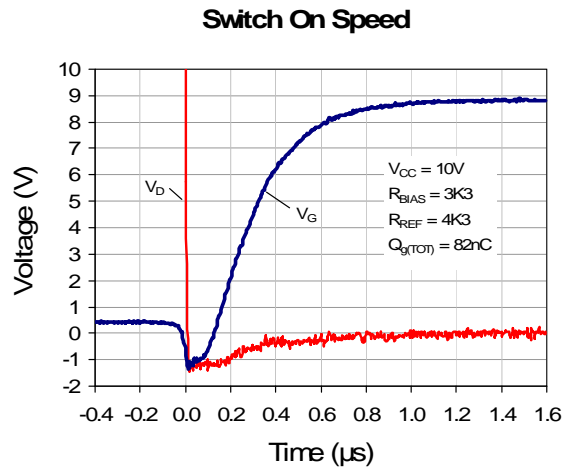

Fig 4b: Typical switch ON speed when driving a $Q_{g(TOT)} = 82nC$ MOSFET

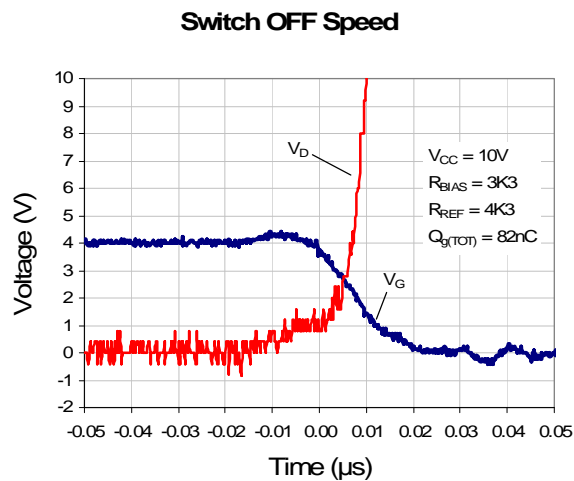

Fig 4c: Typical switch OFF speed when driving a $Q_{g(TOT)} = 82nC$ MOSFET

Design considerations

It is advisable to decouple the ZXGD3103 closely to V_{CC} and ground due to the possibility of high peak gate currents with a 1 μ F X7R type ceramic capacitor as shown in Figure 2. The Gate pins should be as close to the MOSFET's gate as possible. Also the ground return loop should be as short as possible.

To minimize parasitic inductance-induced premature turn-off issue of the synchronous controller always keep the PCB track length between ZXGD3101's Drain input and MOSFET's Drain to less than 10mm. Low internal inductance MOSFET packages such as SO-8 and PolarPak are also recommended for high switching frequency power conversion to minimize body diode conduction.

R1, Q1 D1 and C1 in Figure 1 are only required as a series drop-down regulator to maintain a stable V_{CC} around 10V from a power supply output voltage greater than 15V.

External gate resistors are optional. They can be inserted to control the rise and fall time which may help with EMI issues.

The proper selection of external resistors R_{REF} and R_{BIAS} is important to the optimum device operation. Select a value for resistor R_{REF} and R_{BIAS} from Table 1 based on the desired V_{CC} value. This provides the typical ZXGD3103's detection threshold voltage of 10mV.

Table 1. Recommended resistor values for various supply voltages

V_{CC}	R_{BIAS}	R_{REF}
5V	1K6	2K0
10V	3K3	4K3
12V	3K9	5K1
15V	5K1	6K8

Package Outline and Dimensions

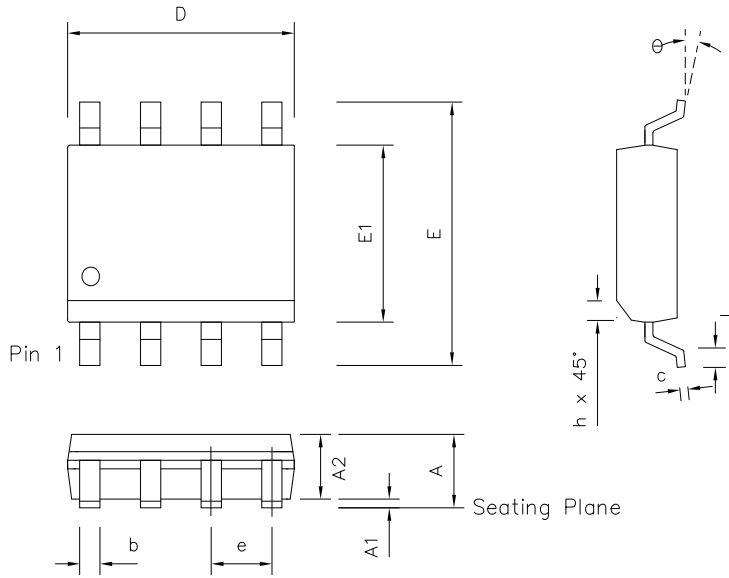

	Min mm	Max mm
A	-	1.75
A1	0.08	0.25
A2	1.30	1.50
D	4.80	5.30
E	5.79	6.20
E1	3.70	4.10
L	0.38	1.27
e	1.27 TYP	
b	0.30	0.50
O	0°	8°
h	-	0.35
All dimensions in mm		

IMPORTANT NOTICE

DIODES INCORPORATED MAKES NO WARRANTY OF ANY KIND, EXPRESS OR IMPLIED, WITH REGARDS TO THIS DOCUMENT, INCLUDING, BUT NOT LIMITED TO, THE IMPLIED WARRANTIES OF MERCHANTABILITY AND FITNESS FOR A PARTICULAR PURPOSE (AND THEIR EQUIVALENTS UNDER THE LAWS OF ANY JURISDICTION).

Diodes Incorporated and its subsidiaries reserve the right to make modifications, enhancements, improvements, corrections or other changes without further notice to this document and any product described herein. Diodes Incorporated does not assume any liability arising out of the application or use of this document or any product described herein; neither does Diodes Incorporated convey any license under its patent or trademark rights, nor the rights of others. Any Customer or user of this document or products described herein in such applications shall assume all risks of such use and will agree to hold Diodes Incorporated and all the companies whose products are represented on Diodes Incorporated website, harmless against all damages.

Diodes Incorporated does not warrant or accept any liability whatsoever in respect of any products purchased through unauthorized sales channel.

Should Customers purchase or use Diodes Incorporated products for any unintended or unauthorized application, Customers shall indemnify and hold Diodes Incorporated and its representatives harmless against all claims, damages, expenses, and attorney fees arising out of, directly or indirectly, any claim of personal injury or death associated with such unintended or unauthorized application.

Products described herein may be covered by one or more United States, international or foreign patents pending. Product names and markings noted herein may also be covered by one or more United States, international or foreign trademarks.

LIFE SUPPORT

Diodes Incorporated products are specifically not authorized for use as critical components in life support devices or systems without the express written approval of the Chief Executive Officer of Diodes Incorporated. As used herein:

A. Life support devices or systems are devices or systems which:

1. are intended to implant into the body, or
2. support or sustain life and whose failure to perform when properly used in accordance with instructions for use provided in the labeling can be reasonably expected to result in significant injury to the user.

B. A critical component is any component in a life support device or system whose failure to perform can be reasonably expected to cause the failure of the life support device or to affect its safety or effectiveness.

Customers represent that they have all necessary expertise in the safety and regulatory ramifications of their life support devices or systems, and acknowledge and agree that they are solely responsible for all legal, regulatory and safety-related requirements concerning their products and any use of Diodes Incorporated products in such safety-critical, life support devices or systems, notwithstanding any devices- or systems-related information or support that may be provided by Diodes Incorporated. Further, Customers must fully indemnify Diodes Incorporated and its representatives against any damages arising out of the use of Diodes Incorporated products in such safety-critical, life support devices or systems.

Copyright © 2010, Diodes Incorporated

www.diodes.com