

**JTB SERIES**

## 外形尺寸 · DIMENSIONS (mm)

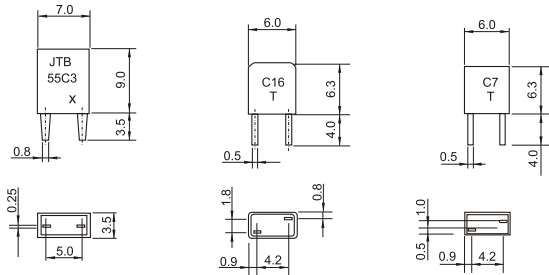
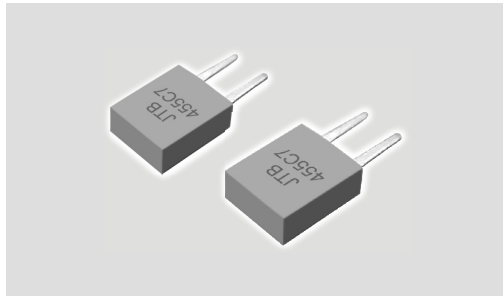

JTB455C3/7/9/10/34

JTB455C4/16

JTB455C3/7/29

**通讯设备用陶瓷鉴频器 · DISCRIMINATOR FOR COMMUNICATION**

Model	Demodulation 3dB Band Width 解调3dB带宽	Demodulation Output(455KHz) 解调输出	Distortion Factor (455KHz) 偏差因素	IMPEDANCE CHARACTERISTICS 阻抗性能				
				Resonant Freq.Fr 谐振频率	Anti-resonant Freq.Fa 反谐振频率	$\Delta F (Fa-Fr)$	Resonant Resistance Rt 谐振电阻	Capacitance C 电容
JTB455C3					455 ± 2.0KHz	48 ± 5KHz	70 Ω max	600PF ± 20%
JTB455C7	± 4.0KHz min	340 ± 60mv	2.5%max					
JTB455C9	± 5.0KHz min	100mv min	1.5%max					
JTB455C10				429 ± 2.0KHz		46KHzmin	70 Ω max	580PF ± 20%
JTB455C34	± 4.0KHz min	65 ± 20mv	2.5%max					
JTB455C4					470 ± 1.0KHz	43 ± 2.0KHz	300 Ω max	140PF ± 20%
JTB455C16	± 4.0KHz min	190 ± 50mv	2.0%max					
JTB455C3					455 ± 1.5KHz	46 ± 5.0KHz	70 Ω max	550PF ± 20%
JTB455C7	± 4.0KHz min	340 ± 60mv	30%max					
JTB455C18	± 3.0KHz min	180 ± 40mv	2.0%max					
JTB455C29	± 4.0KHz min	125 ± 30mv	2.5%max					
JTB455C28	± 4.0KHz min	40 ± 20mv	30%max					
JTB455C38	± 4.0KHz min	40 ± 20mv	30%max					

**集成电路兼容性 · MACHED IC**

MoDEL 型号	IC MAKER 集成电路制造商	IC NUMBER 集成电路型号	NOTEL 注1	NoTEL 注2
JTB455C3	SCNY	CXA1183	*	
JTB455C4	SONY	La8610	*	
JTB455C5	NEC	UPC1167C		*
JTB455C7	MOTOROLA	Mc3357	*	*
JTB455C8	PHILLIPS	TDA1576		*
JTB455C9	SIGNETICS	NE604/5	*	*

\*Note 1 also available in miniature size \*也有小型的  
 \*Note 2 also available in 450KHz \*也有450KHz  
 Note 3 JTB JTBm parts require different external component  
 JTB HTBN元件要求外解不同部件  
 JTB455 系列 (用于正交检波)

MODEL 型号	IC MKER 集成电路制造商	IC NUMBER 集成电路型号	NOTEL 注1	NOTEL 注2
JTB455C10	TOSHIBA	TA8103F	*	
JTB455C11	SIEMENG	S1469		
JTB455C12	PIESSY	SI652		
JTB455C13A	SONY	CXA1003BM	*	
JTB455C16	MOTORLA	Mc3372	*	
JTB455C29	SIGNETICS	Ne605		
JTB455C34	MOTORLA	Mc13136		
JTB455C28	TOSHIBA	Ta31142	*	*
JTB455C32	TOSHIBA	Ta31143	*	*

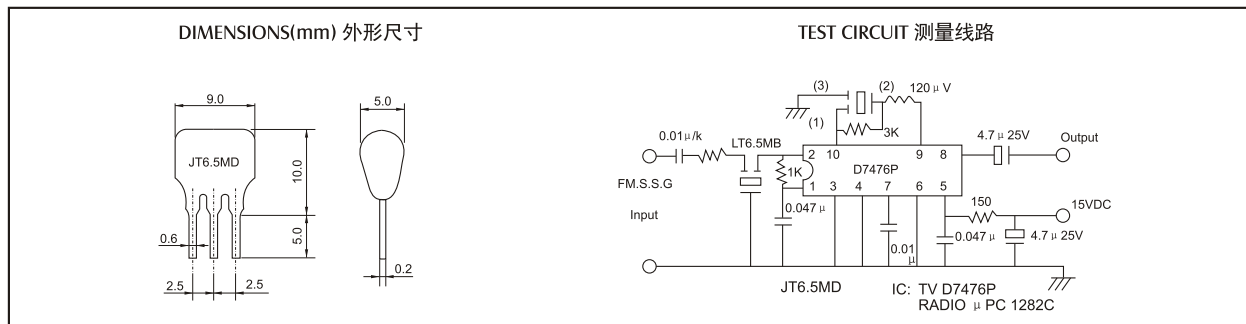
**电视机音频用陶瓷鉴频器 · CERAMIC DISCRIMINATOR FOR TV/VCR IF STAGE**

**主要参数 · PRINCIPAL PARAMETERS**

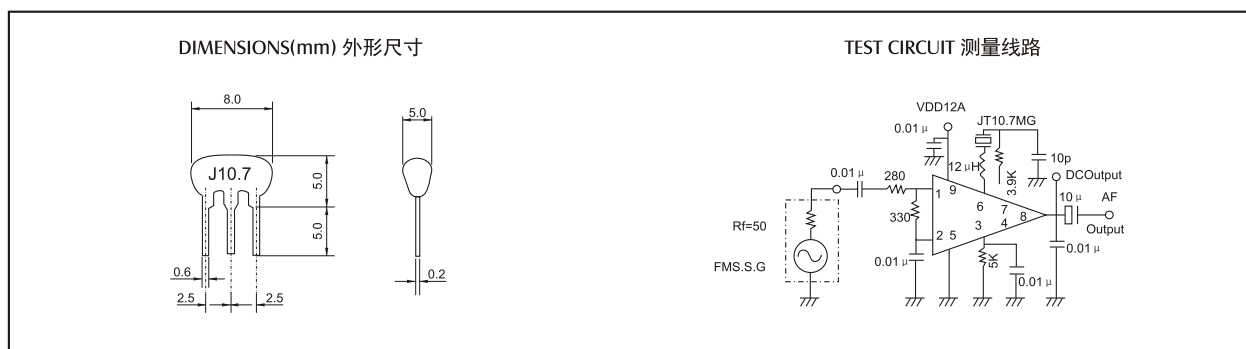
MODEL 型号	RECOVERED AUDIO OUTPUT VOLTAGE 伴音解调输出 (mv) min	DISTORTION FACTOR 解调失真系数 (%) max	RECOVERED AUDIO 3DB BAND WIDTH (KHz)min	DETECTION MODE 检波方式	APPLIED 1C 应用电路
JT4.5MD	100	<3%	$\geq \pm 50$	Diferential Peak 微分峰值检波	TA7176, AN241 $\mu$ PC1353C, LA1365 Ca3065
JT5.5~6.5MD		<3%			
JT4.5MC	140	<3%	$\geq \pm 50$	Quadrature 正交检波	$\mu$ PC1382C, LA7520. $\mu$ PC1391H, TA7146P. TBA120T, M51316p
JT5.5~6.5MC		<3%			

**调频收音机用陶瓷鉴频器 · DISCRIMINATOR FOR FM RADIO**

**主要参数 · PRINCIPAL PARAMETERS**

MODEL 型号	RECOVERED AUDIO OUTPUT VOLTAGE 伴音解调输出 (mv) min	DISTORTION FACTOR 解调失真系数 (%) max	RECOVERED AUDIO 3dB BAND WIDTH (KHz)min	DETECTION MODE 检波方式	APPLIED 1C 应用电路
JT10.7MG1	25	1.0	345	Quadrature 正交检波	CX20029 CX20111
JT10.7MG3	65	1.0	$\pm 150$	Diferential peak 微分峰值检波	TA7303P, TA7130
JT10.7MG33	45	0.7	250	Quadrature 正交检波	TA2007
JT10.7MG92	60	1.0	300	Quadrature 正交检波	TA2132P