

8-channel analog multiplexer/demultiplexer with latch

74HC/HCT4351

FEATURES

- Wide analog input voltage range:
± 5 V
- Low "ON" resistance:
80 Ω (typ.) at $V_{CC} - V_{EE} = 4.5$ V
70 Ω (typ.) at $V_{CC} - V_{EE} = 6.0$ V
60 Ω (typ.) at $V_{CC} - V_{EE} = 9.0$ V
- Logic level translation: to enable 5 V logic to communicate with ± 5 V analog signals
- Typical "break before make" built in
- Address latches provided
- Output capability: non-standard
- I_{CC} category: MSI

GENERAL DESCRIPTION

The 74HC/HCT4351 are high-speed Si-gate CMOS devices. They are specified in compliance with JEDEC standard no. 7A.

The 74HC/HCT4351 are 8-channel analog multiplexers/demultiplexers with three select inputs (S_0 to S_2), two enable inputs (\bar{E}_1 and E_2), a latch enable input (\bar{LE}), eight independent inputs/outputs (Y_0 to Y_7) and a common input/output (Z).

With \bar{E}_1 LOW and E_2 is HIGH, one of the eight switches is selected (low impedance ON-state) by S_0 to S_2 . The data at the select inputs may be latched by using the active LOW latch enable input (\bar{LE}). When \bar{LE} is HIGH the latch is transparent. When either of the two enable inputs, \bar{E}_1 (active LOW) and E_2 (active HIGH), is inactive, all 8 analog switches are turned off.

V_{CC} and GND are the supply voltage pins for the digital control inputs (S_0 to S_2 , \bar{LE} , \bar{E}_1 and E_2). The V_{CC} to GND ranges are 2.0 to 10.0 V for HC and 4.5 to 5.5 V for HCT. The analog inputs/outputs (Y_0 to Y_7 , and Z) can swing between V_{CC} as a positive limit and V_{EE} as a negative limit.

$V_{CC} - V_{EE}$ may not exceed 10.0 V.

For operation as a digital multiplexer/demultiplexer, V_{EE} is connected to GND (typically ground).

QUICK REFERENCE DATA

$V_{EE} = \text{GND} = 0$ V; $T_{\text{amb}} = 25$ °C; $t_r = t_f = 6$ ns

SYMBOL	PARAMETER	CONDITIONS	TYPICAL		UNIT
			HC	HCT	
t_{PZH} / t_{PZL}	turn "ON" time \bar{E}_1 , E_2 or S_n to V_{os}	$C_L = 15$ pF; $R_L = 1$ kΩ; $V_{CC} = 5$ V	27	35	ns
t_{PHZ} / t_{PLZ}	turn "OFF" time \bar{E}_1 , E_2 or S_n to V_{os}		21	23	ns
C_I	input capacitance		3.5	3.5	pF
C_{PD}	power dissipation capacitance per switch	notes 1 and 2	25	25	pF
C_S	max. switch capacitance independent (Y) common (Z)		5	5	pF
			25	25	pF

Notes

1. C_{PD} is used to determine the dynamic power dissipation (P_D in μW):

$$P_D = C_{PD} \times V_{CC}^2 \times f_i + \sum \{(C_L + C_S) \times V_{CC}^2 \times f_o\}$$

where:

f_i = input frequency in MHz

f_o = output frequency in MHz

C_L = output load capacitance in pF

C_S = max. switch capacitance in pF

$\sum \{(C_L + C_S) \times V_{CC}^2 \times f_o\}$ = sum of outputs

V_{CC} = supply voltage in V

2. For HC the condition is $V_I = \text{GND}$ to V_{CC}
For HCT the condition is $V_I = \text{GND}$ to $V_{CC} - 1.5$ V

ORDERING INFORMATION

See "74HC/HCT/HCU/HCMOS Logic Package Information".

8-channel analog multiplexer/demultiplexer with latch

74HC/HCT4351

FUNCTION TABLE

INPUTS						CHANNEL ON
\bar{E}_1	E_2	\bar{LE}	S_2	S_1	S_0	
H	X	X	X	X	X	none
X	L	X	X	X	X	none
L	H	H	L	L	L	Y_0
L	H	H	L	L	H	Y_1
L	H	H	L	H	L	Y_2
L	H	H	L	H	H	Y_3
L	H	H	H	L	L	Y_4
L	H	H	H	L	H	Y_5
L	H	H	H	H	L	Y_6
L	H	H	H	H	H	Y_7
L	H	L	X	X	X	(1)
X	X	↓	X	X	X	(2)

Notes

1. Last selected channel "ON".
2. Selected channels latched.
3. H = HIGH voltage level
L = LOW voltage level
X = don't care
↓ = HIGH-to-LOW \bar{LE} transition

APPLICATIONS

- Analog multiplexing and demultiplexing
- Digital multiplexing and demultiplexing
- Signal gating

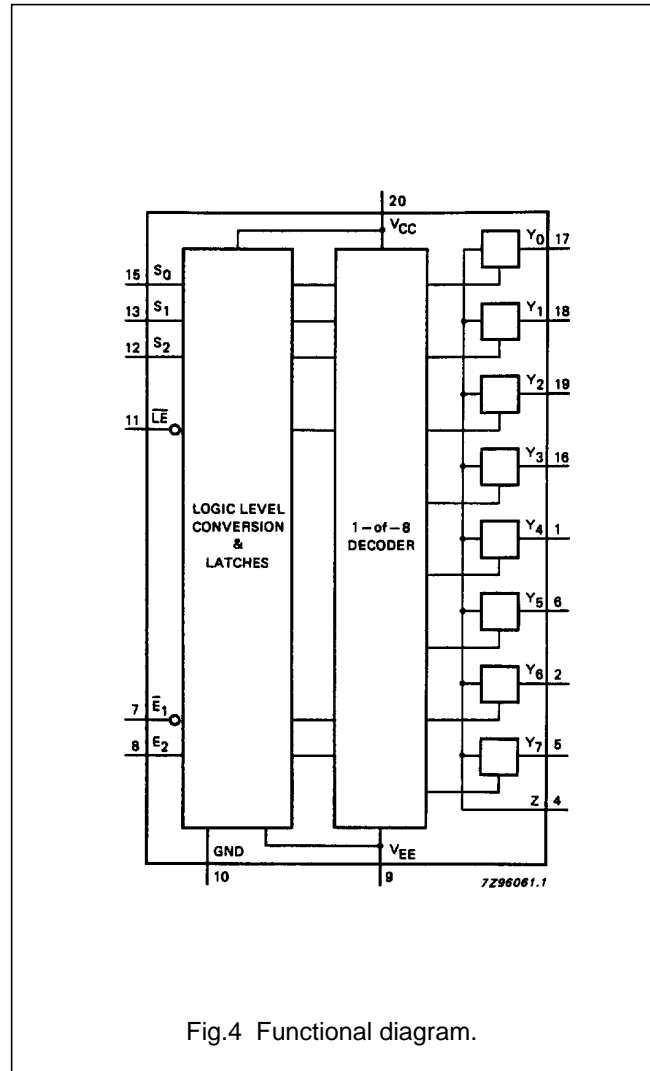

Fig.4 Functional diagram.

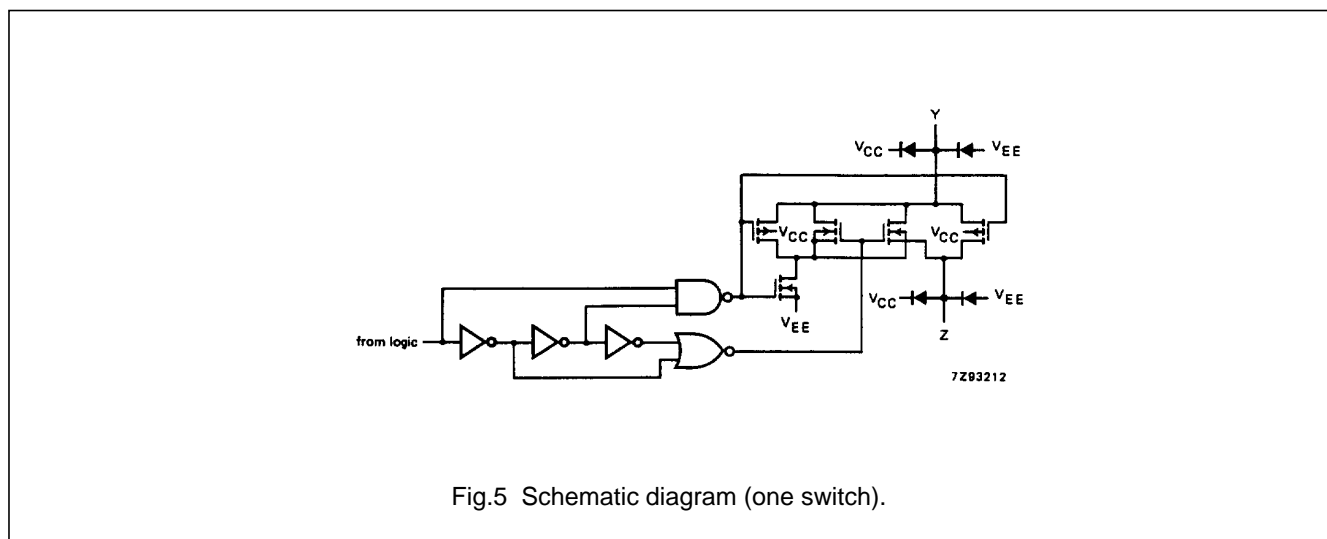

Fig.5 Schematic diagram (one switch).

8-channel analog multiplexer/demultiplexer with latch

74HC/HCT4351

RATINGS

Limiting values in accordance with the Absolute Maximum System (IEC 134)

Voltages are referenced to $V_{EE} = \text{GND}$ (ground = 0 V)

SYMBOL	PARAMETER	MIN.	MAX.	UNIT	CONDITIONS
V_{CC}	DC supply voltage	-0.5	+11.0	V	
$\pm I_{IK}$	DC digital input diode current		20	mA	for $V_I < -0.5 \text{ V}$ or $V_I > V_{CC} + 0.5 \text{ V}$
$\pm I_{SK}$	DC switch diode current		20	mA	for $V_S < -0.5 \text{ V}$ or $V_S > V_{CC} + 0.5 \text{ V}$
$\pm I_S$	DC switch current		25	mA	for $-0.5 \text{ V} < V_S < V_{CC} + 0.5 \text{ V}$
$\pm I_{EE}$	DC V_{EE} current		20	mA	
$\pm I_{CC}; \pm I_{GND}$	DC V_{CC} or GND current		50	mA	
T_{stg}	storage temperature range	-65	+150	°C	
P_{tot}	power dissipation per package				for temperature range: -40 to +125 °C 74HC/HCT
	plastic DIL		750	mW	above +70 °C: derate linearly with 12 mW/K
	plastic mini-pack (SO)		500	mW	above +70 °C: derate linearly with 8 mW/K
P_S	power dissipation per switch		100	mW	

Note to ratings

- To avoid drawing V_{CC} current out of terminal Z, when switch current flows in terminals Y_n , the voltage drop across the bidirectional switch must not exceed 0.4 V. If the switch current flows into terminal Z, no V_{CC} current will flow out of terminals Y_n . In this case there is no limit for the voltage drop across the switch, but the voltages at Y_n and Z may not exceed V_{CC} or V_{EE} .

RECOMMENDED OPERATING CONDITIONS

SYMBOL	PARAMETER	74HC			74HCT			UNIT	CONDITIONS
		min.	typ.	max.	min.	typ.	max.		
V_{CC}	DC supply voltage $V_{CC}-\text{GND}$	2.0	5.0	10.0	4.5	5.0	5.5	V	see Figs 6 and 7
V_{CC}	DC supply voltage $V_{CC}-V_{EE}$	2.0	5.0	10.0	2.0	5.0	10.0	V	see Figs 6 and 7
V_I	DC input voltage range	GND		V_{CC}	GND		V_{CC}	V	
V_S	DC switch voltage range	V_{EE}		V_{CC}	V_{EE}		V_{CC}	V	
T_{amb}	operating ambient temperature range	-40		+85	-40		+85	°C	see DC and AC CHARACTERISTICS
T_{amb}	operating ambient temperature range	-40		+125	-40		+125	°C	
t_r, t_f	input rise and fall times		6.0	1000 500 400 250		6.0	500	ns	$V_{CC} = 2.0 \text{ V}$ $V_{CC} = 4.5 \text{ V}$ $V_{CC} = 6.0 \text{ V}$ $V_{CC} = 10.0 \text{ V}$

8-channel analog multiplexer/demultiplexer with latch

74HC/HCT4351

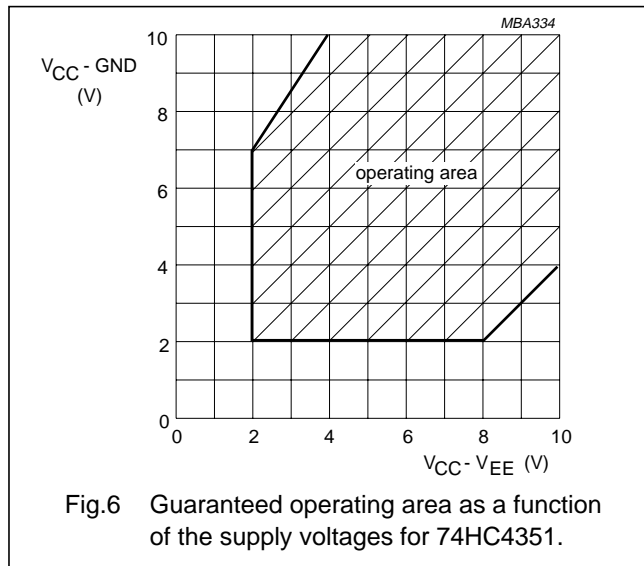

Fig.6 Guaranteed operating area as a function of the supply voltages for 74HC4351.

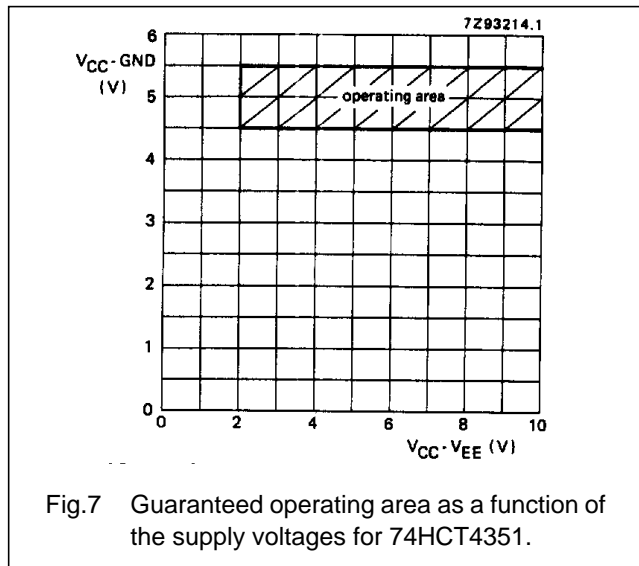

Fig.7 Guaranteed operating area as a function of the supply voltages for 74HCT4351.

DC CHARACTERISTICS FOR 74HC/HCT

For 74HC: $V_{CC} - GND$ or $V_{CC} - V_{EE} = 2.0, 4.5, 6.0$ and 9.0 V

For 74HCT: $V_{CC} - GND = 4.5$ and 5.5 V; $V_{CC} - V_{EE} = 2.0, 4.5, 6.0$ and 9.0 V

SYMBOL	PARAMETER	T_{amb} (°C)						UNIT	TEST CONDITIONS					
		74HC/HCT							V_{CC} (V)	V_{EE} (V)	I_s (µA)	V_{is}	V_i	
		+25			-40 to +85		-40 to +125							
		min.	typ.	max.	min.	max.	min.							max.
R_{ON}	ON resistance (rail)		—	—		—		—	Ω	2.0	0	100	V_{CC} to V_{EE}	V_{IH} or V_{IL}
			100	180		225		270	Ω	4.5	0	1000		
			90	160		200		240	Ω	6.0	0	1000		
			70	130		165		195	Ω	4.5	-4.5	1000		
R_{ON}	ON resistance (rail)		150	—		—		—	Ω	2.0	0	100	V_{EE}	V_{IH} or V_{IL}
			80	140		175		210	Ω	4.5	0	1000		
			70	120		150		180	Ω	6.0	0	1000		
			60	105		130		160	Ω	4.5	-4.5	1000		
R_{ON}	ON resistance (rail)		150	—		—		—	Ω	2.0	0	100	V_{CC}	V_{IH} or V_{IL}
			90	160		200		240	Ω	4.5	0	1000		
			80	140		175		210	Ω	6.0	0	1000		
			65	120		150		180	Ω	4.5	-4.5	1000		
ΔR_{ON}	maximum Δ ON resistance between any two channels		—						Ω	2.0	0		V_{CC} to V_{EE}	V_{IH} or V_{IL}
			9						Ω	4.5	0			
			8						Ω	6.0	0			
			6						Ω	4.5	-4.5			

Notes to DC characteristics

- At supply voltages ($V_{CC} - V_{EE}$) approaching 2.0 V, the analog switch ON-resistance becomes extremely non-linear. There it is recommended that these devices be used to transmit digital signals only, when using these supply voltages.
- For test circuit measuring R_{ON} see Fig.8.

8-channel analog multiplexer/demultiplexer with latch

74HC/HCT4351

DC CHARACTERISTICS FOR 74HC

Voltages are referenced to GND (ground = 0 V)

SYMBOL	PARAMETER	T _{amb} (°C)							UNIT	TEST CONDITIONS			
		74HC								V _{CC} (V)	V _{EE} (V)	V _I	OTHER
		+25			-40 to +85		-40 to +125						
		min.	typ.	max.	min.	max.	min.	max.					
V _{IH}	HIGH level input voltage	1.5 3.15 4.2 6.3	1.2 2.4 3.2 4.7		1.5 3.15 4.2 6.3		1.5 3.15 4.2 6.3		V	2.0 4.5 6.0 9.0			
V _{IL}	LOW level input voltage		0.8 2.1 2.8 4.3	0.5 1.35 1.8 2.7		0.5 1.35 1.8 2.7		0.5 1.35 1.8 2.7	V	2.0 4.5 6.0 9.0			
±I _I	input leakage current			0.1 0.2		1.0 2.0		1.0 2.0	µA	6.0 10.0	0 0	V _{CC} or GND	
±I _S	analog switch OFF-state current per channel			0.1		1.0		1.0	µA	10.0	0	V _{IH} or V _{IL}	I _S = V _{CC} - V _{EE} (see Fig.10)
±I _S	analog switch OFF-state current all channels			0.4		4.0		4.0	µA	10.0	0	V _{IH} or V _{IL}	I _S = V _{CC} - V _{EE} (see Fig.10)
±I _S	analog switch ON-state current			0.4		4.0		4.0	µA	10.0	0	V _{IH} or V _{IL}	I _S = V _{CC} - V _{EE} (see Fig.11)
I _{CC}	quiescent supply current			8.0 16.0		80.0 160.0		160.0 320.0	µA	6.0 10.0	0 0	V _{CC} or GND	V _{is} = V _{EE} or V _{CC} ; V _{os} = V _{CC} or V _{EE}

8-channel analog multiplexer/demultiplexer with latch

74HC/HCT4351

AC CHARACTERISTICS FOR 74HCGND = 0 V; $t_r = t_f = 6$ ns; $C_L = 50$ pF

SYMBOL	PARAMETER	T_{amb} (°C)						UNIT	TEST CONDITIONS			
		74HC							V_{CC} (V)	V_{EE} (V)	OTHER	
		+25			-40 to +85		-40 to +125					
		min.	typ.	max.	min.	max.	min.		max.			
t_{PHL}/t_{PLH}	propagation delay V_{is} to V_{os}		14 5 4 4	60 12 10 8		75 15 13 10		90 18 15 12	ns	2.0 4.5 6.0 4.5	0 0 0 -4.5	$R_L = \infty$; $C_L = 50$ pF (see Fig.17)
t_{PZH}/t_{PZL}	turn "ON" time \bar{E}_1 to V_{os}		85 31 25 28	300 60 51 55		375 75 64 69		450 90 77 83	ns	2.0 4.5 6.0 4.5	0 0 0 -4.5	$R_L = 1$ k Ω ; $C_L = 50$ pF (see Fig.18)
t_{PZH}/t_{PZL}	turn "ON" time E_2 to V_{os}		85 31 25 25	300 60 51 55		375 75 64 69		450 90 77 83	ns	2.0 4.5 6.0 4.5	0 0 0 -4.5	$R_L = 1$ k Ω ; $C_L = 50$ pF (see Fig.18)
t_{PZH}/t_{PZL}	turn "ON" time \bar{LE} to V_{os}		91 33 26 27	300 60 51 55		375 75 64 69		450 90 77 83	ns	2.0 4.5 6.0 4.5	0 0 0 -4.5	$R_L = 1$ k Ω ; $C_L = 50$ pF (see Fig.18)
t_{PZH}/t_{PZL}	turn "ON" time S_n to V_{os}		88 32 26 25	300 60 51 50		375 75 64 63		450 90 77 75	ns	2.0 4.5 6.0 4.5	0 0 0 -4.5	$R_L = 1$ k Ω ; $C_L = 50$ pF (see Fig.18)
t_{PHZ}/t_{PLZ}	turn "OFF" time \bar{E}_1 to V_{os}		69 25 20 20	250 50 43 40		315 63 54 50		375 75 64 60	ns	2.0 4.5 6.0 4.5	0 0 0 -4.5	$R_L = 1$ k Ω ; $C_L = 50$ pF (see Fig.18)
t_{PHZ}/t_{PLZ}	turn "OFF" time E_2 to V_{os}		72 26 21 19	250 50 43 40		315 63 54 50		375 75 64 60	ns	2.0 4.5 6.0 4.5	0 0 0 -4.5	$R_L = 1$ k Ω ; $C_L = 50$ pF (see Fig.18)
t_{PHZ}/t_{PLZ}	turn "OFF" time \bar{LE} to V_{os}		83 30 24 26	275 55 47 45		345 69 59 56		415 83 71 68	ns	2.0 4.5 6.0 4.5	0 0 0 -4.5	$R_L = 1$ k Ω ; $C_L = 50$ pF (see Fig.18)
t_{PHZ}/t_{PLZ}	turn "OFF" time S_n to V_{os}		80 29 23 24	275 55 47 48		345 69 59 60		415 83 71 72	ns	2.0 4.5 6.0 4.5	0 0 0 -4.5	$R_L = 1$ k Ω ; $C_L = 50$ pF (see Fig.18)

8-channel analog multiplexer/demultiplexer
with latch

74HC/HCT4351

SYMBOL	PARAMETER	T _{amb} (°C)							UNIT	TEST CONDITIONS		
		74HC								V _{CC} (V)	V _{EE} (V)	OTHER
		+25			-40 to +85		-40 to +125					
		min.	typ.	max.	min.	max.	min.	max.				
t _{su}	set-up time S _n to $\overline{\text{LE}}$	60	17			75		90	ns	2.0	0	R _L = 1 kΩ; C _L = 50 pF (see Fig.19)
		12	6			15		18		4.5	0	
		10	5			13		15		6.0	0	
		18	9			23		27		4.5	-4.5	
t _h	hold time S _n to $\overline{\text{LE}}$	5	-8			5		5	ns	2.0	0	R _L = 1 kΩ; C _L = 50 pF (see Fig.19)
		5	-3			5		5		4.5	0	
		5	-2			5		5		6.0	0	
		5	-4			5		5		4.5	-4.5	
t _w	$\overline{\text{LE}}$ minimum pulse width HIGH	100	11			125		150	ns	2.0	0	R _L = 1 kΩ; C _L = 50 pF (see Fig.19)
		20	1			25		30		4.5	0	
		17	3			21		26		6.0	0	
		25	7			31		38		4.5	-4.5	

8-channel analog multiplexer/demultiplexer with latch

74HC/HCT4351

ADDITIONAL AC CHARACTERISTICS FOR 74HC/HCT

Recommended conditions and typical values

GND = 0 V; $T_{amb} = 25\text{ }^{\circ}\text{C}$

SYMBOL	PARAMETER	typ.	UNIT	V_{CC} (V)	V_{EE} (V)	$V_{is(p-p)}$ (V)	CONDITIONS
	sine-wave distortion $f = 1\text{ kHz}$	0.04 0.02	% %	2.25 4.5	-2.25 -4.5	4.0 8.0	$R_L = 10\text{ k}\Omega$; $C_L = 50\text{ pF}$ (see Fig.14)
	sine-wave distortion $f = 10\text{ kHz}$	0.12 0.06	% %	2.25 4.5	-2.25 -4.5	4.0 8.0	$R_L = 10\text{ k}\Omega$; $C_L = 50\text{ pF}$ (see Fig.14)
	switch "OFF" signal feed-through	-50 -50	dB dB	2.25 4.5	-2.25 -4.5	note 1	$R_L = 600\text{ }\Omega$; $C_L = 50\text{ pF}$ (see Figs 12 and 15)
$V_{(p-p)}$	crosstalk voltage between control and any switch (peak-to-peak value)	120 220	mV mV	4.5 4.5	0 -4.5		$R_L = 600\text{ }\Omega$; $C_L = 50\text{ pF}$; $f = 1\text{ MHz}$ (E_1 , E_2 or S_n , square-wave between V_{CC} and GND, $t_r = t_f = 6\text{ ns}$) (see Fig.16)
f_{max}	minimum frequency response (-3dB)	160 170	MHz MHz	2.25 4.5	-2.25 -4.5	note 2	$R_L = 50\text{ }\Omega$; $C_L = 10\text{ pF}$ (see Figs 13 and 14)
C_S	maximum switch capacitance independent (Y) common (Z)	5 25	pF pF				

Notes to AC characteristics

- Adjust input voltage V_{is} to 0 dBm level (0 dBm = 1 mW into 600 Ω).
- Adjust input voltage V_{is} to 0 dBm level at V_{os} for 1 MHz (0 dBm = 1 mW into 50 Ω).

V_{is} is the input voltage at a Y_n or Z terminal, whichever is assigned as an input.

V_{os} is the output voltage at a Y_n or Z terminal, whichever is assigned as an output.

