

# 120X120X38 mm

# SUNON

NEW



## 95-117 CFM

Model	P/N	Bearing	Rating Voltage (VAC)	Freq. (Hz)	Power Current (AMP)	Power Consumption (WATTS)	Speed (RPM)	Air Flow (CFM)	Static Pressure (Inch-H <sub>2</sub> O)	Noise (dBA)	Weight (g)
A1123-HST	GN	⊙	115	50/60	0,28/0,25	23/20	2700/3100	95/115	0,33/0,38	44/49	525
A1123-HSL	GN	⊙	115	50/60	0,28/0,25	23/20	2700/3100	95/115	0,33/0,38	44/49	525
A1123-HBT	GN	○	115	50/60	0,28/0,25	23/20	2700/3100	97/117	0,34/0,39	45/50	525
A1123-HBL	GN	○	115	50/60	0,28/0,25	23/20	2700/3100	97/117	0,34/0,39	45/50	525
A2123-HST	GN	⊙	220-240	50/60	0,14/0,12	23/20	2700/3100	95/115	0,33/0,38	44/49	525
A2123-HSL	GN	⊙	220-240	50/60	0,14/0,12	23/20	2700/3100	95/115	0,33/0,38	44/49	525
A2123-HBT	GN	○	220-240	50/60	0,14/0,12	23/20	2700/3100	97/117	0,34/0,39	45/50	525
A2123-HBL	GN	○	220-240	50/60	0,14/0,12	23/20	2700/3100	97/117	0,34/0,39	45/50	525

Frame : Aluminum alloy

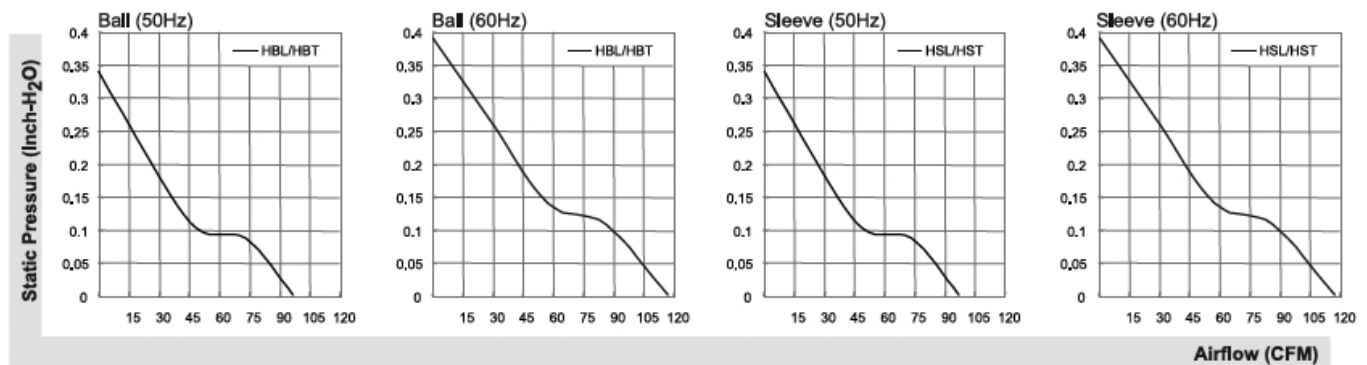

UNITS:mm

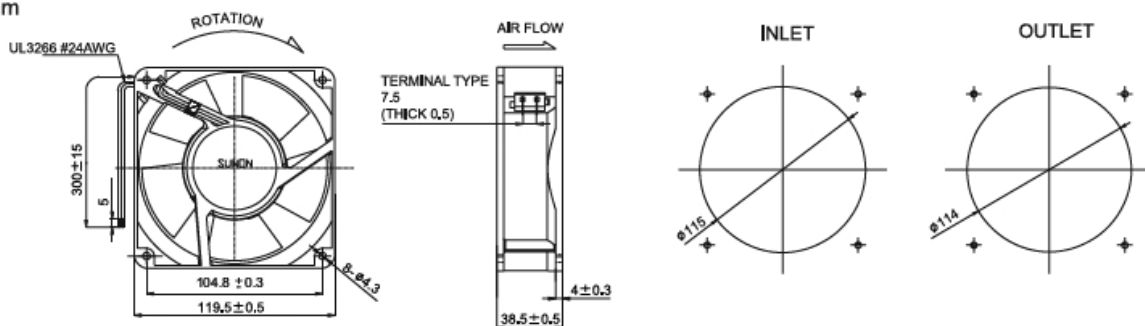

\*All model could be customized on voltage or any other requirements to fit your need.

\*Specifications subject to change without notice. Please Visit SUNON web site at <http://www.sunon.com> for update information.