

2SK3875-01

N-CHANNEL SILICON POWER MOSFET

FUJI POWER MOSFET Super FAP-G Series

Features

- High speed switching, Low on-resistance
- Low driving power, Avalanche-proof
- No secondary breakdown

Applications

- Switching regulators
- UPS (Uninterruptible Power Supply)
- DC-DC converters

Maximum ratings and characteristic

Absolute maximum ratings (Tc=25°C unless otherwise specified)

Item	Symbol	Ratings	Unit	Remarks
Drain-source voltage	V _{DS}	900	V	
	V _{DSX}	900	V	V _{GS} =-30V
Continuous Drain Current	I _D	13	A	
Pulsed Drain Current	I _{D(puls)}	±52	A	
Gate-Source Voltage	V _{GS}	±30	V	
Non-Repetitive Maximum Avalanche current	I _{AS}	13	A	Note *1
Repetitive Maximum Avalanche current	I _{AR}	6.5	A	
Non-Repetitive Maximum Avalanche Energy	E _{AS}	1006	mJ	Note *2
Repetitive Maximum Avalanche Energy	E _{AR}	35.5	mJ	Note *3
Maximum Drain-Source dV/dt	dV _{DS} /dt	40	kV/μs	V _{DS} ≤ 900V
Peak Diode Recovery dV/dt	dV/dt	5	kV/μs	Note *4
Max. Power Dissipation	P _D	355	W	T _c =25°C
		2.50		T _a =25°C
Operating and Storage Temperature range	T _{ch}	+150	°C	
	T _{stg}	-55 to +150	°C	

Outline Drawings (mm)

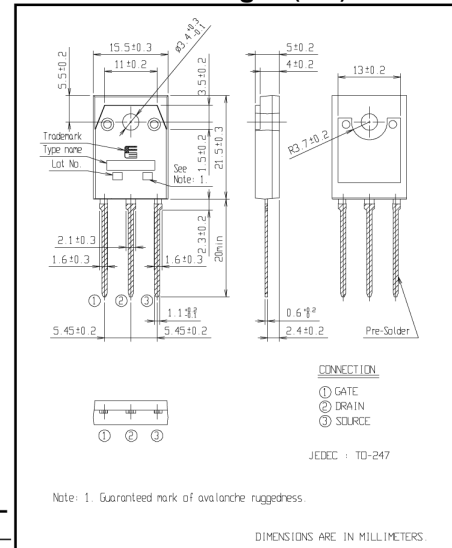

Equivalent circuit schematic

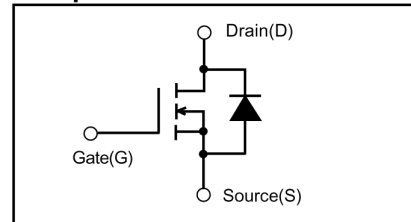

Note *1: T_{ch} ≤ 150°C

Note *2: Starting T_{ch}=25°C, I_{AS}=5.2A, L=67.5mH, V_{CC}=100V, R_G=50Ω

E_{AS} limited by maximum channel temperature and Avalanche current.

See to the 'Avalanche Energy' graph

Note *3: Repetitive rating: Pulse width limited by maximum channel temperature.

See to the 'Transient Thermal impedance' graph.

Note *4: I_F ≤ -I_D, -di/dt=50A/μs, V_{CC} ≤ BV_{DSS}, T_{ch} ≤ 150°C

Electrical characteristics (T_c =25°C unless otherwise specified)

Item	Symbol	Test Conditions	Min.	Typ.	Max.	Units
Drain-Source Breakdown Voltage	BV _{DSS}	I _D = 250μA V _{GS} =0V	900			V
Gate Threshold Voltage	V _{GS(th)}	I _D = 250μA V _{DS} =V _{GS}	3.0		5.0	V
Zero Gate Voltage Drain Current	I _{DSS}	V _{DS} =900V V _{GS} =0V			25	μA
		V _{DS} =720V V _{GS} =0V			250	
Gate-Source Leakage Current	I _{GSS}	V _{GS} =±30V V _{DS} =0V			100	nA
Drain-Source On-State Resistance	R _{DS(on)}	I _D =6.5A V _{GS} =10V		0.79	1.00	Ω
Forward Transconductance	g _{fs}	I _D =6.5A V _{DS} =25V	6.0	12		S
Input Capacitance	C _{iss}	V _{DS} =25V		1750	2625	pF
Output Capacitance	C _{oss}	V _{GS} =0V		220	330	
Reverse Transfer Capacitance	C _{rss}	f=1MHz		13	19.5	
Turn-On Time t _{on}	t _{d(on)}	V _{CC} =600V I _D =6.5A		20	30	ns
		V _{GS} =10V		12	18	
Turn-Off Time t _{off}	t _{d(off)}	R _{GS} =10 Ω		60	90	
				15	22.5	
Total Gate Charge	Q _G	V _{CC} =450V		46	69	nC
Gate-Source Charge	Q _{GS}	I _D =13A		14	21	
Gate-Drain Charge	Q _{GD}	V _{GS} =10V		17	26	
Diode forward on-voltage	V _{SD}	I _F =13A V _{GS} =0V T _{ch} =25°C		1.10	1.50	V
Reverse recovery time	t _{rr}	I _F =13A V _{GS} =0V		4.5		μs
Reverse recovery charge	Q _{rr}	-di/dt=100A/μs T _{ch} =25°C		25		μC

Thermal characteristics

Item	Symbol	Test Conditions	Min.	Typ.	Max.	Units
Thermal resistance	R _{th(ch-c)}	channel to case			0.352	°C/W
	R _{th(ch-a)}	channel to ambient			50.0	°C/W