

4K I²C™ Serial EEPROM

Device Selection Table

Part Number	Vcc Range	Max. Clock Frequency	Temp. Ranges
24AA04	1.7-5.5	400 kHz ⁽¹⁾	I
24LC04B	2.5-5.5	400 kHz	I, E

Note 1: 100 kHz for Vcc < 2.5V

Features:

- Single supply with operation down to 1.7V for 24AA04 devices, 2.5V for 24LC04B devices
- Low-power CMOS technology:
 - Read current 1 mA, typical
 - Standby current 1 μ A, typical
- 2-wire serial interface, I²C™ compatible
- Schmitt Trigger inputs for noise suppression
- Output slope control to eliminate ground bounce
- 100 kHz and 400 kHz clock compatibility
- Page write time 3 ms, typical
- Self-timed erase/write cycle
- 16-byte page write buffer
- Hardware write-protect
- ESD protection >4,000V
- More than 1 million erase/write cycles
- Data retention >200 years
- Factory programming available
- Packages include 8-lead PDIP, SOIC, TSSOP, DFN, MSOP and 5-lead SOT-23
- Pb-free and RoHS compliant
- Temperature ranges:
 - Industrial (I): -40°C to +85°C
 - Automotive (E): -40°C to +125°C

Description:

The Microchip Technology Inc. 24AA04/24LC04B (24XX04*) is a 4 Kbit Electrically Erasable PROM. The device is organized as two blocks of 256 x 8-bit memory with a 2-wire serial interface. Low-voltage design permits operation down to 1.7V, with standby and active currents of only 1 μ A and 1 mA, respectively. The 24XX04 also has a page write capability for up to 16 bytes of data. The 24XX04 is available in the standard 8-pin PDIP, surface mount SOIC, TSSOP, 2x3 DFN and MSOP packages and is also available in the 5-lead SOT-23 package.

Package Types

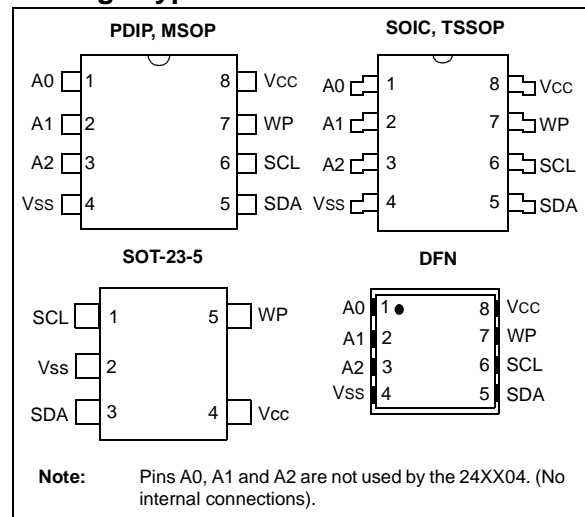

Block Diagram

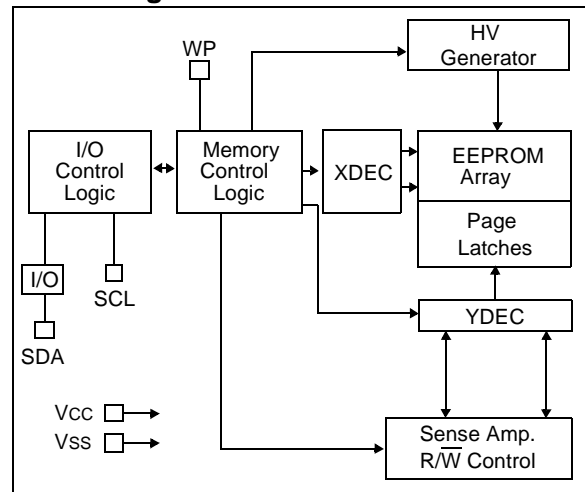

24AA04/24LC04B

1.0 ELECTRICAL CHARACTERISTICS

Absolute Maximum Ratings (†)

V _{CC}	6.5V
All inputs and outputs w.r.t. V _{SS}	-0.3V to V _{CC} +1.0V
Storage temperature	-65°C to +150°C
Ambient temperature with power applied	-40°C to +125°C
ESD protection on all pins	≥ 4 kV

† NOTICE: Stresses above those listed under “Absolute Maximum Ratings” may cause permanent damage to the device. This is a stress rating only and functional operation of the device at those or any other conditions above those indicated in the operational listings of this specification is not implied. Exposure to maximum rating conditions for extended periods may affect device reliability.

TABLE 1-1: DC CHARACTERISTICS

DC CHARACTERISTICS			Industrial (I): TA = -40°C to +85°C, V _{CC} = +1.7V to +5.5V Automotive (E): TA = -40°C to +125°C, V _{CC} = +2.5V to +5.5V				
Param. No.	Sym.	Characteristic	Min.	Typ.	Max.	Units	Conditions
D1	V _{IH}	WP, SCL and SDA pins	—	—	—	—	—
D2	—	High-level input voltage	0.7 V _{CC}	—	—	V	—
D3	V _{IL}	Low-level input voltage	—	—	0.3 V _{CC}	V	—
D4	V _{HYS}	Hysteresis of Schmitt Trigger inputs	0.05 V _{CC}	—	—	V	(Note)
D5	V _{OL}	Low-level output voltage	—	—	0.40	V	I _{OL} = 3.0 mA, V _{CC} = 2.5V
D6	I _{LI}	Input leakage current	—	—	±1	μA	V _{IN} = V _{SS} or V _{CC}
D7	I _{LO}	Output leakage current	—	—	±1	μA	V _{OUT} = V _{SS} or V _{CC}
D8	C _{IN} , C _{OUT}	Pin capacitance (all inputs/outputs)	—	—	10	pF	V _{CC} = 5.0V (Note) TA = 25°C, F _{CLK} = 1 MHz
D9	I _{CC} write	Operating current	—	0.1	3	mA	V _{CC} = 5.5V, SCL = 400 kHz
D10	I _{CC} read		—	0.05	1	mA	—
D11	I _{CCS}	Standby current	—	0.01	1	μA	Industrial Automotive SDA = SCL = V _{CC} WP = V _{SS}
			—	—	5	μA	

Note: This parameter is periodically sampled and not 100% tested.

TABLE 1-2: AC CHARACTERISTICS

AC CHARACTERISTICS			Industrial (I): TA = -40°C to +85°C, VCC = +1.7V to +5.5V Automotive (E): TA = -40°C to +125°C, VCC = +2.5V to +5.5V				
Param. No.	Sym.	Characteristic	Min.	Typ.	Max.	Units	Conditions
1	FCLK	Clock frequency	— —	— —	400 100	kHz	2.5V ≤ VCC ≤ 5.5V 1.7V ≤ VCC < 2.5V (24AA04)
2	THIGH	Clock high time	600 4000	— —	— —	ns	2.5V ≤ VCC ≤ 5.5V 1.7V ≤ VCC < 2.5V (24AA04)
3	TLOW	Clock low time	1300 4700	— —	— —	ns	2.5V ≤ VCC ≤ 5.5V 1.7V ≤ VCC < 2.5V (24AA04)
4	TR	SDA and SCL rise time (Note 1)	— —	— —	300 1000	ns	2.5V ≤ VCC ≤ 5.5V (Note 1) 1.7V ≤ VCC < 2.5V (24AA04) (Note 1)
5	TF	SDA and SCL fall time	—	— —	300	ns	(Note 1)
6	THD:STA	Start condition hold time	600 4000	— —	— —	ns	2.5V ≤ VCC ≤ 5.5V 1.7V ≤ VCC < 2.5V (24AA04)
7	TSU:STA	Start condition setup time	600 4700	— —	— —	ns	2.5V ≤ VCC ≤ 5.5V 1.7V ≤ VCC < 2.5V (24AA04)
8	THD:DAT	Data input hold time	0	— —	—	ns	(Note 2)
9	TSU:DAT	Data input setup time	100 250	— —	— —	ns	2.5V ≤ VCC ≤ 5.5V 1.7V ≤ VCC < 2.5V (24AA04)
10	TSU:STO	Stop condition setup time	600 4000	— —	— —	ns	2.5V ≤ VCC ≤ 5.5V 1.7V ≤ VCC < 2.5V (24AA04)
11	TAA	Output valid from clock (Note 2)	— —	— —	900 3500	ns	2.5V ≤ VCC ≤ 5.5V 1.7V ≤ VCC < 2.5V (24AA04)
12	TBUF	Bus free time: Time the bus must be free before a new transmission can start	1300 4700	— —	— —	ns	2.5V ≤ VCC ≤ 5.5V 1.7V ≤ VCC < 2.5V (24AA04)
13	TOF	Output fall time from VIH minimum to VIL maximum	20+0.1CB —	— —	250 250	ns	2.5V ≤ VCC ≤ 5.5V 1.7V ≤ VCC < 2.5V (24AA04)
14	TSP	Input filter spike suppression (SDA and SCL pins)	—	—	50	ns	(Notes 1 and 3)
15	TWC	Write cycle time (byte or page)	—	—	5	ms	—
16	—	Endurance	1M	—	—	cycles	25°C, (Note 4)

Note 1: Not 100% tested. CB = total capacitance of one bus line in pF.

- 2:** As a transmitter, the device must provide an internal minimum delay time to bridge the undefined region (minimum 300 ns) of the falling edge of SCL to avoid unintended generation of Start or Stop conditions.
- 3:** The combined TSP and VHYS specifications are due to new Schmitt Trigger inputs which provide improved noise spike suppression. This eliminates the need for a Ti specification for standard operation.
- 4:** This parameter is not tested but ensured by characterization. For endurance estimates in a specific application, please consult the Total Endurance™ Model which can be obtained from Microchip's web site

8-Lead Plastic Small Outline (SN or OA) – Narrow, 3.90 mm Body [SOIC]

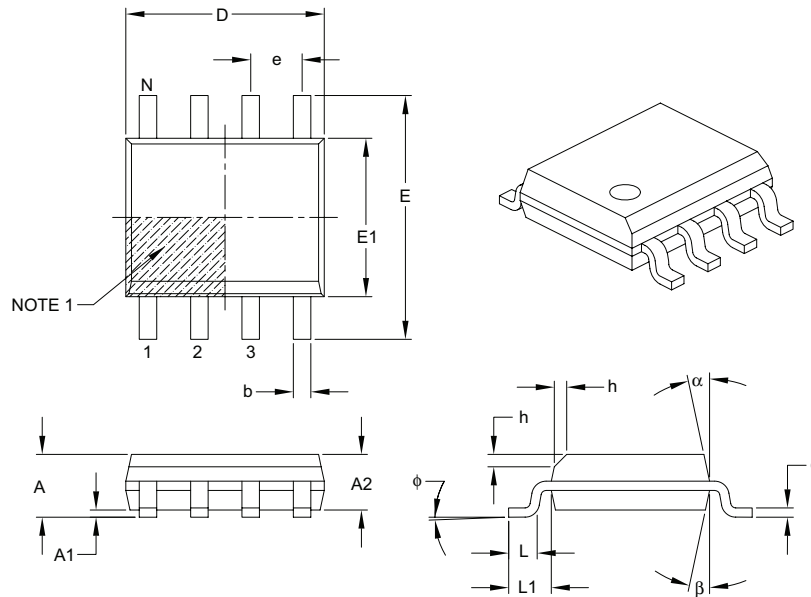

Dimension Limits	Units	MILLIMETERS		
		MIN	NOM	MAX
Number of Pins	N	8		
Pitch	e	1.27 BSC		
Overall Height	A	–	–	1.75
Molded Package Thickness	A2	1.25	–	–
Standoff §	A1	0.10	–	0.25
Overall Width	E	6.00 BSC		
Molded Package Width	E1	3.90 BSC		
Overall Length	D	4.90 BSC		
Chamfer (optional)	h	0.25	–	0.50
Foot Length	L	0.40	–	1.27
Footprint	L1	1.04 REF		
Foot Angle	ϕ	0°	–	8°
Lead Thickness	c	0.17	–	0.25
Lead Width	b	0.31	–	0.51
Mold Draft Angle Top	α	5°	–	15°
Mold Draft Angle Bottom	β	5°	–	15°

Notes:

- Pin 1 visual index feature may vary, but must be located within the hatched area.
- § Significant Characteristic.
- Dimensions D and E1 do not include mold flash or protrusions. Mold flash or protrusions shall not exceed 0.15 mm per side.
- Dimensioning and tolerancing per ASME Y14.5M.

BSC: Basic Dimension. Theoretically exact value shown without tolerances.

REF: Reference Dimension, usually without tolerance, for information purposes only.

Microchip Technology Drawing C04-057B

PRODUCT IDENTIFICATION SYSTEM

To order or obtain information, e.g., on pricing or delivery, refer to the factory or the listed sales office.

PART NO.		X	XX
Device	Temperature Range		Package
<p>Device:</p> <p>24AA04: = 1.7V, 4 Kbit I²C Serial EEPROM 24AA04T: = 1.7V, 4 Kbit I²C Serial EEPROM (Tape and Reel) 24LC04B: = 2.5V, 4 Kbit I²C Serial EEPROM 24LC04BT: = 2.5V, 4 Kbit I²C Serial EEPROM (Tape and Reel)</p> <p>Temperature Range:</p> <p>I = -40°C to +85°C E = -40°C to +125°C</p> <p>Package:</p> <p>MC = 2x3 DFN, 8-lead P = Plastic DIP (300 mil body), 8-lead SN = Plastic SOIC (3.90 mm body), 8-lead ST = Plastic TSSOP (4.4 mm), 8-lead MS = Plastic Micro Small Outline (MSOP), 8-lead OT = SOT-23, 5-lead (Tape and Reel only)</p>			
<p>Examples:</p> <p>a) 24AA04-I/P: Industrial Temperature, 1.7V, PDIP package b) 24AA04-I/SN: Industrial Temperature, 1.7V, SOIC package c) 24AA04T-I/OT: Industrial Temperature, 1.7V, SOT-23 package, tape and reel d) 24LC04B-I/P: Industrial Temperature, 2.5V, PDIP package e) 24LC04B-E/SN: Extended Temperature, 2.5V, SOIC package f) 24LC04BT-I/OT: Industrial Temperature, 2.5V, SOT-23 package, tape and reel</p>			