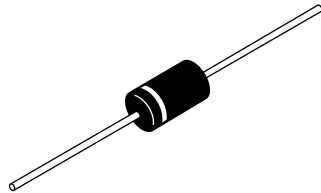
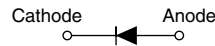

Schottky Rectifier, 3.3 A

C-16

FEATURES

- Low profile, axial leaded outline
- High frequency operation
- Very low forward voltage drop
- High purity, high temperature epoxy encapsulation for enhanced mechanical strength and moisture resistance
- Guard ring for enhanced ruggedness and long term reliability
- Lead (Pb)-free plating
- Designed and qualified for industrial level

RoHS
COMPLIANT

PRODUCT SUMMARY

$I_{F(AV)}$	3.3 A
V_R	50/60 V

DESCRIPTION

The 31DQ.. axial leaded Schottky rectifier has been optimized for very low forward voltage drop, with moderate leakage. Typical applications are in switching power supplies, converters, freewheeling diodes, and reverse battery protection

MAJOR RATINGS AND CHARACTERISTICS

SYMBOL	CHARACTERISTICS	VALUES	UNITS
$I_{F(AV)}$	Rectangular waveform	3.3	A
V_{RRM}		50/60	V
I_{FSM}	$t_p = 5 \mu s$ sine	340	A
V_F	3 Apk, $T_J = 25^\circ C$	0.62	V
T_J		- 40 to 150	$^\circ C$

VOLTAGE RATINGS

PARAMETER	SYMBOL	31DQ05	31DQ06	UNITS
Maximum DC reverse voltage	V_R	50	60	V
Maximum working peak reverse voltage	V_{RWM}			

ABSOLUTE MAXIMUM RATINGS

PARAMETER	SYMBOL	TEST CONDITIONS	VALUES	UNITS
Maximum average forward current See fig. 4	$I_{F(AV)}$	50 % duty cycle at $T_L = 105^\circ C$, rectangular waveform	3.3	A
Maximum peak one cycle non-repetitive surge current See fig. 6	I_{FSM}	5 μs sine or 3 μs rect. pulse	340	
		10 ms sine or 6 ms rect. pulse	55	
Non-repetitive avalanche energy	E_{AS}	$T_J = 25^\circ C$, $I_{AS} = 1 A$, $L = 10 mH$	5.0	mJ
Repetitive avalanche current	I_{AR}	Current decaying linearly to zero in 1 μs Frequency limited by T_J maximum $V_A = 1.5 \times V_R$ typical	1.0	A

ELECTRICAL SPECIFICATIONS					
PARAMETER	SYMBOL	TEST CONDITIONS		VALUES	UNITS
Maximum forward voltage drop See fig. 1	$V_{FM}^{(1)}$	3 A	$T_J = 25\text{ }^\circ\text{C}$	0.62	V
		6 A		0.78	
		3 A	$T_J = 125\text{ }^\circ\text{C}$	0.54	
		6 A		0.65	
Maximum reverse leakage current See fig. 4	$I_{RM}^{(1)}$	$T_J = 25\text{ }^\circ\text{C}$	$V_R = \text{Rated } V_R$	2	mA
		$T_J = 125\text{ }^\circ\text{C}$		15	
Typical junction capacitance	C_T	$V_R = 5\text{ }V_{DC}$ (test signal range 100 kHz to 1 MHz) $25\text{ }^\circ\text{C}$		160	pF
Typical series inductance	L_S	Measured lead to lead 5 mm from package body		9.0	nH
Maximum voltage rate of charge	dV/dt	Rated V_R		10 000	V/ μ s

Note

(1) Pulse width < 300 μ s, duty cycle < 2 %

THERMAL - MECHANICAL SPECIFICATIONS					
PARAMETER	SYMBOL	TEST CONDITIONS		VALUES	UNITS
Maximum junction and storage temperature range	$T_J^{(1)}, T_{Stg}$			- 40 to 150	$^\circ\text{C}$
Maximum thermal resistance, junction to ambient	R_{thJA}	DC operation Without cooling fin		80	$^\circ\text{C}/\text{W}$
Typical thermal resistance, junction to lead	R_{thJL}	DC operation		15	
Approximate weight				1.2	g
				0.042	oz.
Marking device		Case style C-16		31DQ05	
				31DQ06	

Note

(1) $\frac{dP_{tot}}{dT_J} < \frac{1}{R_{thJA}}$ thermal runaway condition for a diode on its own heatsink

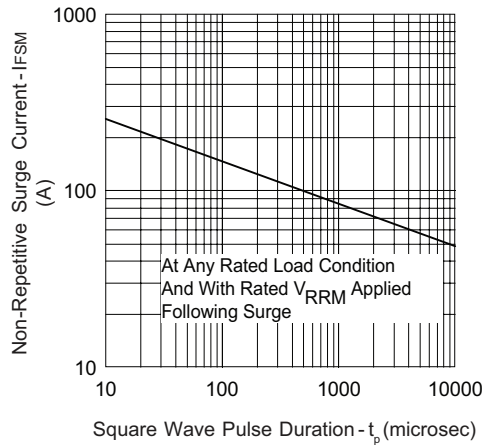

Fig. 6 - Maximum Non-Repetitive Surge Current

ORDERING INFORMATION TABLE

Device code	31	D	Q	06	TR
	①	②	③	④	⑤

1	-	31 = 3.1 A (axial and small packages - current is x 10)
2	-	D = DO-201 package
3	-	Q = Schottky Q.. series
4	-	06 = Voltage ratings
5	-	• TR = Tape and reel package (1200 pcs) • None = Box package (500 pcs)

05 = 50 V
 06 = 60 V

Axial DO-201AD (C-16)

DIMENSIONS in millimeters (inches)

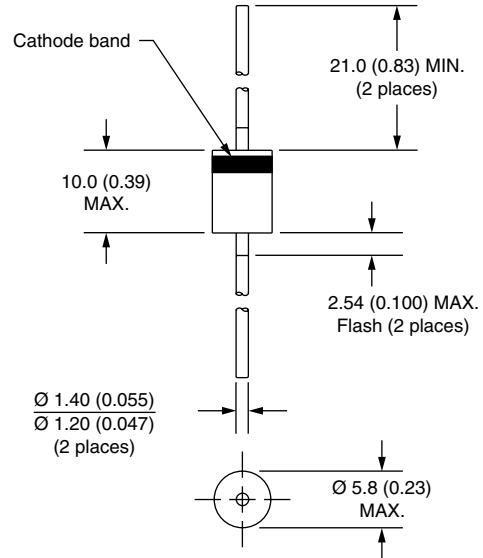
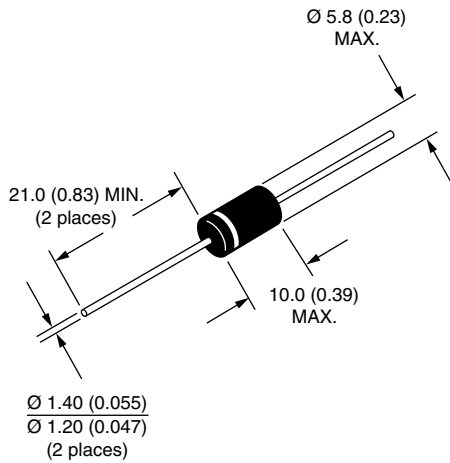

Schottky Axial < 4 A for DO-201AD (C-16)

Axial devices are packed in accordance with EIA standard RS-296-D and specification.

COMPONENT OUTLINE	COMPONENT PITCH A ± 0.5 mm (0.020")	INNER TAPE PITCH B ± 1.5 mm (0.059")	CUMULATIVE PITCH TOLERANCE	QUANTITY PER REEL	QUANTITY PER CARTON
DO-201AD	10.0 mm	52.4 mm	2.0 mm/10 pitch	1200	4800

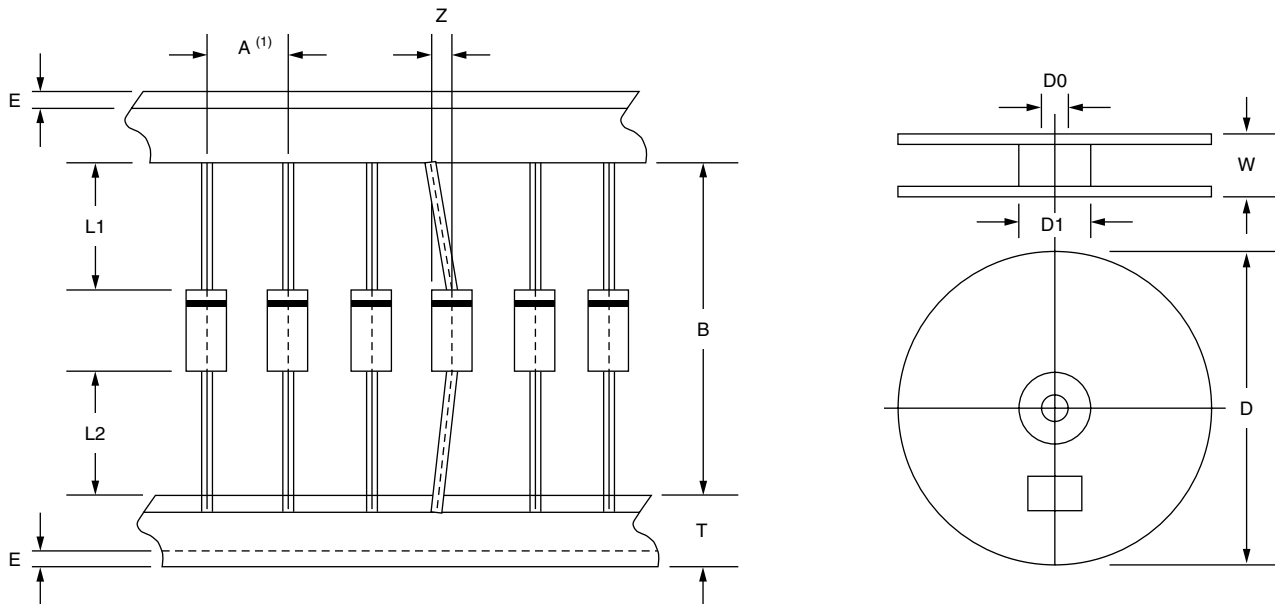

ITEM	SYMBOL	SPECIFICATIONS (mm)	SPECIFICATIONS (INCHES)
Component alignment	Z	1.2 maximum	0.048 maximum
Tape width	T	6.0 ± 0.4	0.236 ± 0.016
Exposed adhesive	E	0.8 maximum	0.032 maximum
Body eccentricity	L1-L2	1.0 maximum	0.040 maximum
Reel outside diameter	D	330.0	13.0
Reel inner diameter	D1	85.7 ± 0.3	3.375 ± 0.012
Feed hole diameter	D0	16.6 ± 0.4	0.655 ± 0.016
Reel width ⁽²⁾	W	79.0 ± 1.0	3.110 ± 0.040

Notes

(1) Each component lead shall be sandwiched between tapes for a minimum of 3.2 mm (0.126")

(2) The reel width "W" for 26 mm taping is 50.0 ± 1.0 mm (1.97" ± 0.040")