

# LM158/LM258/LM358/LM2904

## Low Power Dual Operational Amplifiers

### General Description

The LM158 series consists of two independent, high gain, internally frequency compensated operational amplifiers which were designed specifically to operate from a single power supply over a wide range of voltages. Operation from split power supplies is also possible and the low power supply current drain is independent of the magnitude of the power supply voltage.

Application areas include transducer amplifiers, dc gain blocks and all the conventional op amp circuits which now can be more easily implemented in single power supply systems. For example, the LM158 series can be directly operated off of the standard +5V power supply voltage which is used in digital systems and will easily provide the required interface electronics without requiring the additional  $\pm 15V$  power supplies.

The LM358 and LM2904 are available in a chip sized package (8-Bump micro SMD) using National's micro SMD package technology.

### Unique Characteristics

- In the linear mode the input common-mode voltage range includes ground and the output voltage can also swing to ground, even though operated from only a single power supply voltage.
- The unity gain cross frequency is temperature compensated.
- The input bias current is also temperature compensated.

### Advantages

- Two internally compensated op amps
- Eliminates need for dual supplies
- Allows direct sensing near GND and  $V_{OUT}$  also goes to GND
- Compatible with all forms of logic
- Power drain suitable for battery operation

### Features

- Available in 8-Bump micro SMD chip sized package, (See AN-1112)
- Internally frequency compensated for unity gain
- Large dc voltage gain: 100 dB
- Wide bandwidth (unity gain): 1 MHz (temperature compensated)
- Wide power supply range:
  - Single supply: 3V to 32V
  - or dual supplies:  $\pm 1.5V$  to  $\pm 16V$
- Very low supply current drain (500  $\mu A$ )—essentially independent of supply voltage
- Low input offset voltage: 2 mV
- Input common-mode voltage range includes ground
- Differential input voltage range equal to the power supply voltage
- Large output voltage swing

### Voltage Controlled Oscillator (VCO)

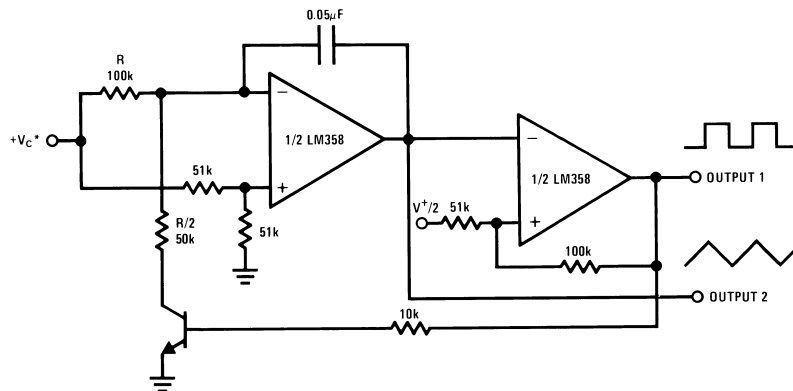

00778723

**Absolute Maximum Ratings** (Note 9)

If Military/Aerospace specified devices are required,  
please contact the National Semiconductor Sales Office/

Distributors for availability and specifications.

	LM158/LM258/LM358 LM158A/LM258A/LM358A	LM2904
Supply Voltage, V <sup>+</sup>	32V	26V
Differential Input Voltage	32V	26V
Input Voltage	-0.3V to +32V	-0.3V to +26V
Power Dissipation (Note 1)		
Molded DIP	830 mW	830 mW
Metal Can	550 mW	
Small Outline Package (M)	530 mW	530 mW
micro SMD	435mW	
Output Short-Circuit to GND (One Amplifier) (Note 2) V <sup>+</sup> ≤ 15V and T <sub>A</sub> = 25°C	Continuous	Continuous
Input Current (V <sub>IN</sub> < -0.3V) (Note 3)	50 mA	50 mA
Operating Temperature Range		
LM358	0°C to +70°C	-40°C to +85°C
LM258	-25°C to +85°C	
LM158	-55°C to +125°C	
Storage Temperature Range	-65°C to +150°C	-65°C to +150°C
Lead Temperature, DIP (Soldering, 10 seconds)	260°C	260°C
Lead Temperature, Metal Can (Soldering, 10 seconds)	300°C	300°C
Soldering Information		
Dual-In-Line Package		
Soldering (10 seconds)	260°C	260°C
Small Outline Package		
Vapor Phase (60 seconds)	215°C	215°C
Infrared (15 seconds)	220°C	220°C
See AN-450 "Surface Mounting Methods and Their Effect on Product Reliability" for other methods of soldering surface mount devices.		
ESD Tolerance (Note 10)	250V	250V

**Electrical Characteristics**

V<sup>+</sup> = +5.0V, unless otherwise stated

Parameter	Conditions	LM158A			LM358A			LM158/LM258			Units
		Min	Typ	Max	Min	Typ	Max	Min	Typ	Max	
Input Offset Voltage	(Note 5), T <sub>A</sub> = 25°C	1	2		2	3		2	5		mV
Input Bias Current	I <sub>IN(+)</sub> or I <sub>IN(-)</sub> , T <sub>A</sub> = 25°C, V <sub>CM</sub> = 0V, (Note 6)	20	50		45	100		45	150		nA
Input Offset Current	I <sub>IN(+)</sub> - I <sub>IN(-)</sub> , V <sub>CM</sub> = 0V, T <sub>A</sub> = 25°C	2	10		5	30		3	30		nA
Input Common-Mode Voltage Range	V <sup>+</sup> = 30V, (Note 7) (LM2904, V <sup>+</sup> = 26V), T <sub>A</sub> = 25°C	0		V <sup>+</sup> -1.5	0		V <sup>+</sup> -1.5	0		V <sup>+</sup> -1.5	V
Supply Current	Over Full Temperature Range R <sub>L</sub> = ∞ on All Op Amps V <sup>+</sup> = 30V (LM2904 V <sup>+</sup> = 26V) V <sup>+</sup> = 5V										
		1	2		1	2		1	2		mA
		0.5	1.2		0.5	1.2		0.5	1.2		mA

## Electrical Characteristics

$V^+ = +5.0V$ , unless otherwise stated

Parameter	Conditions	LM358			LM2904			Units
		Min	Typ	Max	Min	Typ	Max	
Input Offset Voltage	(Note 5), $T_A = 25^\circ C$		2	7		2	7	mV
Input Bias Current	$I_{IN(+)}$ or $I_{IN(-)}$ , $T_A = 25^\circ C$ , $V_{CM} = 0V$ , (Note 6)		45	250		45	250	nA
Input Offset Current	$I_{IN(+)} - I_{IN(-)}$ , $V_{CM} = 0V$ , $T_A = 25^\circ C$		5	50		5	50	nA
Input Common-Mode Voltage Range	$V^+ = 30V$ , (Note 7) (LM2904, $V^+ = 26V$ ), $T_A = 25^\circ C$	0		$V^+ - 1.5$	0		$V^+ - 1.5$	V
Supply Current	Over Full Temperature Range $R_L = \infty$ on All Op Amps $V^+ = 30V$ (LM2904 $V^+ = 26V$ ) $V^+ = 5V$		1 0.5	2 1.2		1 0.5	2 1.2	mA mA

## Electrical Characteristics

$V^+ = +5.0V$ , (Note 4), unless otherwise stated

Parameter	Conditions	LM158A			LM358A			LM158/LM258			Units
		Min	Typ	Max	Min	Typ	Max	Min	Typ	Max	
Large Signal Voltage Gain	$V^+ = 15V$ , $T_A = 25^\circ C$ , $R_L \geq 2 k\Omega$ , (For $V_O = 1V$ to $11V$ )	50	100		25	100		50	100		V/mV
Common-Mode Rejection Ratio	$T_A = 25^\circ C$ , $V_{CM} = 0V$ to $V^+ - 1.5V$	70	85		65	85		70	85		dB
Power Supply Rejection Ratio	$V^+ = 5V$ to $30V$ (LM2904, $V^+ = 5V$ to $26V$ ), $T_A = 25^\circ C$	65	100		65	100		65	100		dB
Amplifier-to-Amplifier Coupling	$f = 1 kHz$ to $20 kHz$ , $T_A = 25^\circ C$ (Input Referred), (Note 8)		-120			-120			-120		dB
Output Current	Source $V_{IN^+} = 1V$ , $V_{IN^-} = 0V$ , $V^+ = 15V$ , $V_O = 2V$ , $T_A = 25^\circ C$	20	40		20	40		20	40		mA
	Sink $V_{IN^-} = 1V$ , $V_{IN^+} = 0V$ $V^+ = 15V$ , $T_A = 25^\circ C$ , $V_O = 2V$	10	20		10	20		10	20		mA
	$V_{IN^-} = 1V$ , $V_{IN^+} = 0V$ $T_A = 25^\circ C$ , $V_O = 200 mV$ , $V^+ = 15V$	12	50		12	50		12	50		$\mu A$
Short Circuit to Ground	$T_A = 25^\circ C$ , (Note 2), $V^+ = 15V$	40	60		40	60		40	60		mA
Input Offset Voltage	(Note 5)		4			5			7		mV
Input Offset Voltage Drift	$R_S = 0\Omega$		7	15		7	20		7		$\mu V/^\circ C$
Input Offset Current	$I_{IN(+)} - I_{IN(-)}$		30			75			100		nA
Input Offset Current Drift	$R_S = 0\Omega$		10	200		10	300		10		$pA/^\circ C$
Input Bias Current	$I_{IN(+)}$ or $I_{IN(-)}$		40	100		40	200		40	300	nA
Input Common-Mode Voltage Range	$V^+ = 30V$ , (Note 7) (LM2904, $V^+ = 26V$ )	0		$V^+ - 2$	0		$V^+ - 2$	0		$V^+ - 2$	V

**Electrical Characteristics** (Continued)V<sup>+</sup> = +5.0V, (Note 4), unless otherwise stated

Parameter	Conditions	LM158A			LM358A			LM158/LM258			Units			
		Min	Typ	Max	Min	Typ	Max	Min	Typ	Max				
Large Signal Voltage Gain	V <sup>+</sup> = +15V (V <sub>O</sub> = 1V to 11V) R <sub>L</sub> ≥ 2 kΩ	25			15			25			V/mV			
Output Voltage	V <sub>OH</sub> V <sup>+</sup> = +30V (LM2904, V <sup>+</sup> = 26V)	R <sub>L</sub> = 2 kΩ			26			26			V			
		R <sub>L</sub> = 10 kΩ			27	28		27	28		V			
Swing	V <sub>OL</sub> V <sup>+</sup> = 5V, R <sub>L</sub> = 10 kΩ	5			20			5			20	mV		
Output Current	Source	V <sub>IN<sup>+</sup></sub> = +1V, V <sub>IN<sup>-</sup></sub> = 0V, V <sup>+</sup> = 15V, V <sub>O</sub> = 2V			10			20			10		20	mA
	Sink	V <sub>IN<sup>-</sup></sub> = +1V, V <sub>IN<sup>+</sup></sub> = 0V, V <sup>+</sup> = 15V, V <sub>O</sub> = 2V			10			15			5		8	mA

**Electrical Characteristics**V<sup>+</sup> = +5.0V, (Note 4), unless otherwise stated

Parameter	Conditions	LM358			LM2904			Units						
		Min	Typ	Max	Min	Typ	Max							
Large Signal Voltage Gain	V <sup>+</sup> = 15V, T <sub>A</sub> = 25°C, R <sub>L</sub> ≥ 2 kΩ, (For V <sub>O</sub> = 1V to 11V)	25			100			25		100	V/mV			
Common-Mode Rejection Ratio	T <sub>A</sub> = 25°C, V <sub>CM</sub> = 0V to V <sup>+</sup> -1.5V	65			85			50		70	dB			
Power Supply Rejection Ratio	V <sup>+</sup> = 5V to 30V (LM2904, V <sup>+</sup> = 5V to 26V), T <sub>A</sub> = 25°C	65			100			50		100	dB			
Amplifier-to-Amplifier Coupling	f = 1 kHz to 20 kHz, T <sub>A</sub> = 25°C (Input Referred), (Note 8)				-120					-120	dB			
Output Current	Source	V <sub>IN<sup>+</sup></sub> = 1V, V <sub>IN<sup>-</sup></sub> = 0V, V <sup>+</sup> = 15V, V <sub>O</sub> = 2V, T <sub>A</sub> = 25°C			20			40			20		40	mA
	Sink	V <sub>IN<sup>-</sup></sub> = 1V, V <sub>IN<sup>+</sup></sub> = 0V V <sup>+</sup> = 15V, T <sub>A</sub> = 25°C, V <sub>O</sub> = 2V			10			20			10		20	mA
		V <sub>IN<sup>-</sup></sub> = 1V, V <sub>IN<sup>+</sup></sub> = 0V T <sub>A</sub> = 25°C, V <sub>O</sub> = 200 mV, V <sup>+</sup> = 15V			12			50			12		50	μA
Short Circuit to Ground	T <sub>A</sub> = 25°C, (Note 2), V <sup>+</sup> = 15V				40			60			40		60	mA
Input Offset Voltage	(Note 5)				9						10		mV	
Input Offset Voltage Drift	R <sub>S</sub> = 0Ω				7						7		μV/°C	
Input Offset Current	I <sub>IN(+)</sub> - I <sub>IN(-)</sub>				150			45			200		nA	
Input Offset Current Drift	R <sub>S</sub> = 0Ω				10						10		pA/°C	
Input Bias Current	I <sub>IN(+)</sub> or I <sub>IN(-)</sub>				40			500			40		500	nA
Input Common-Mode Voltage Range	V <sup>+</sup> = 30 V, (Note 7) (LM2904, V <sup>+</sup> = 26V)	0			V <sup>+</sup> -2			0			V <sup>+</sup> -2		V	

**Electrical Characteristics** (Continued)V<sup>+</sup> = +5.0V, (Note 4), unless otherwise stated

Parameter	Conditions	LM358			LM2904			Units
		Min	Typ	Max	Min	Typ	Max	
Large Signal Voltage Gain	V <sup>+</sup> = +15V (V <sub>O</sub> = 1V to 11V) R <sub>L</sub> ≥ 2 kΩ	15			15			V/mV
Output Voltage Swing	V <sub>OH</sub>	26			22			V
	V <sub>OL</sub>	5			5			mV
Output Current	Source	10			10			mA
	Sink	5			5			mA

**Note 1:** For operating at high temperatures, the LM358/LM358A, LM2904 must be derated based on a +125°C maximum junction temperature and a thermal resistance of 120°C/W for MDIP, 182°C/W for Metal Can, 189°C/W for Small Outline package, and 230°C/W for micro SMD, which applies for the device soldered in a printed circuit board, operating in a still air ambient. The LM258/LM258A and LM158/LM158A can be derated based on a +150°C maximum junction temperature. The dissipation is the total of both amplifiers—use external resistors, where possible, to allow the amplifier to saturate or to reduce the power which is dissipated in the integrated circuit.

**Note 2:** Short circuits from the output to V<sup>+</sup> can cause excessive heating and eventual destruction. When considering short circuits to ground, the maximum output current is approximately 40 mA independent of the magnitude of V<sup>+</sup>. At values of supply voltage in excess of +15V, continuous short-circuits can exceed the power dissipation ratings and cause eventual destruction. Destructive dissipation can result from simultaneous shorts on all amplifiers.

**Note 3:** This input current will only exist when the voltage at any of the input leads is driven negative. It is due to the collector-base junction of the input PNP transistors becoming forward biased and thereby acting as input diode clamps. In addition to this diode action, there is also lateral NPN parasitic transistor action on the IC chip. This transistor action can cause the output voltages of the op amps to go to the V<sup>+</sup> voltage level (or to ground for a large overdrive) for the time duration that an input is driven negative. This is not destructive and normal output states will re-establish when the input voltage, which was negative, again returns to a value greater than -0.3V (at 25°C).

**Note 4:** These specifications are limited to -55°C ≤ T<sub>A</sub> ≤ +125°C for the LM158/LM158A. With the LM258/LM258A, all temperature specifications are limited to -25°C ≤ T<sub>A</sub> ≤ +85°C, the LM358/LM358A temperature specifications are limited to 0°C ≤ T<sub>A</sub> ≤ +70°C, and the LM2904 specifications are limited to -40°C ≤ T<sub>A</sub> ≤ +85°C.

**Note 5:** V<sub>O</sub> = 1.4V, R<sub>S</sub> = 0Ω with V<sup>+</sup> from 5V to 30V; and over the full input common-mode range (0V to V<sup>+</sup> -1.5V) at 25°C. For LM2904, V<sup>+</sup> from 5V to 26V.

**Note 6:** The direction of the input current is out of the IC due to the PNP input stage. This current is essentially constant, independent of the state of the output so no loading change exists on the input lines.

**Note 7:** The input common-mode voltage of either input signal voltage should not be allowed to go negative by more than 0.3V (at 25°C). The upper end of the common-mode voltage range is V<sup>+</sup> -1.5V (at 25°C), but either or both inputs can go to +32V without damage (+26V for LM2904), independent of the magnitude of V<sup>+</sup>.

**Note 8:** Due to proximity of external components, insure that coupling is not originating via stray capacitance between these external parts. This typically can be detected as this type of capacitance increases at higher frequencies.

**Note 9:** Refer to RETS158AX for LM158A military specifications and to RETS158X for LM158 military specifications.

**Note 10:** Human body model, 1.5 kΩ in series with 100 pF.

## Ordering Information

Package	Temperature Range				NSC Drawing
	-55°C to 125°C	-25°C to 85°C	0°C to 70°C	-40°C to 85°C	
SO-8			LM358AM LM358AMX LM358M LM358MX	LM2904M LM2904MX	M08A
8-Pin Molded DIP			LM358AN LM358N	LM2904N	N08E
8-Pin Ceramic DIP	LM158AJ/883(Note 11) LM158J/883(Note 11) LM158J LM158AJLQML(Note 12) LM158AJQMLV(Note 12)				J08A
TO-5, 8-Pin Metal Can	LM158AH/883(Note 11) LM158H/883(Note 11) LM158AH LM158H LM158AHLQML(Note 12) LM158AHLQMLV(Note 12)	LM258H	LM358H		H08C
8-Bump micro SMD			LM358BP LM358BPX	LM2904IBP LM2904IBPX	BPA08AAB 0.85 mm Thick
8-Bump micro SMD Lead Free			LM358TP LM358TPX	LM2904ITP LM2904ITPX	TPA08AAA 0.50 mm Thick
14-Pin Ceramic SOIC	LM158AWG/883				WG10A

**Note 11:** LM158 is available per SMD #5962-8771001

LM158A is available per SMD #5962-8771002

**Note 12:** See STD Mil DWG 5962L87710 for Radiation Tolerant Devices

**Physical Dimensions** inches (millimeters) unless otherwise noted

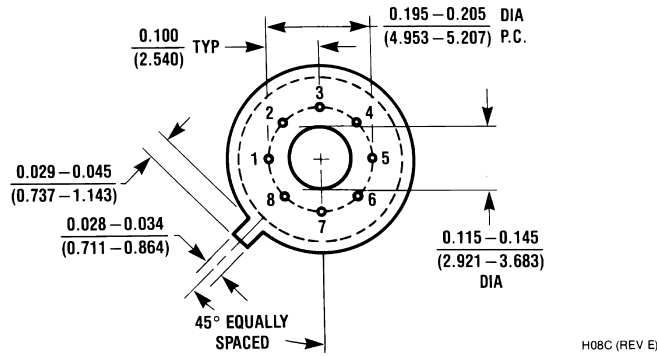
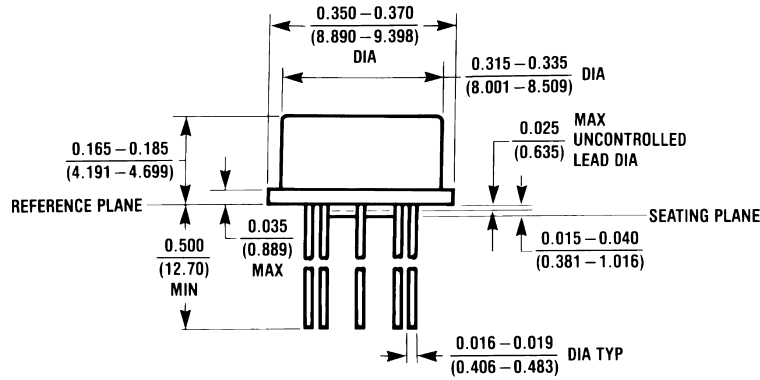

**Metal Can Package (H)**  
NS Package Number H08C

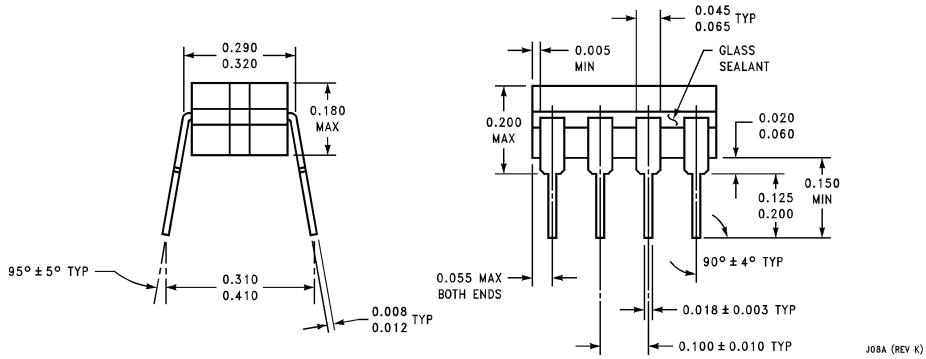
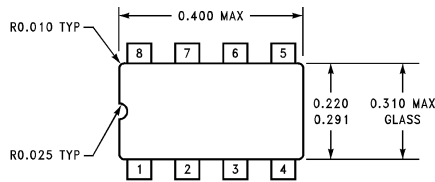

**CerDip Package (J)**  
NS Package Number J08A