



Compact Photoelectric Sensor

The CX-400 series of photoelectric sensors is a wide-ranging lineup of 116 different models. Whatever your application entails, SUNX has covered it with this series. Built to IP-67 standards, the CX-400 series is designed for the most demanding environments.

There are also models that are specifically design for resistance to oil, coolant, or ethanol. Couple this with high electrical noise resistance and a built in interference prevention function, and you have one of the most robust sensors on the market.

The CX-400 series is compact in size (W11.2mm x H31.0mm x D20.0mm) with a world standard mounting pitch of 25.4mm. Wiring options include a M8 quick disconnect, M12 quick disconnect, or built-in wire type with a length of 0.5m, 2m, or 5m.

High precision optics as well as high performance circuitry provides extremely stable sensing for determining small height differences, detecting transparent objects, and subtle color differences. Also, the series offers a high luminance beam spot that achieves long distances and can be as small as 2mm in diameter for detection of minute objects.

Four sensing types are available:

- **Diffuse Reflective**

Available in 100, 300, and 800mm detecting distance models, along with a narrow view type that has a 2mm diameter beam spot.

- **Thru-beam**

Available in 10m and a longest in its class 15m detecting distance models. The ultra long range 15m version is made possible by utilizing a powerful infrared LED light source which is great for powering through dust and dirt as well.

- **Retro-Reflective**

Standard models are available in 3 and 5m detecting distance types. Specialized models for transparent object detection are also available in 0.5 and 2m detecting distances.

- **Adjustable Range Reflective**

Available in 50, 100, and 300m detecting distance models, with the addition of a 2mm diameter small beam spot type. These sensors also incorporate foreground suppression and background suppression functions to limit the effect of unwanted detection.

All types are available with NPN or PNP transistor outputs.

Model Name	Model Pic	Type	Output Operation	Output Configuration	Emitting Element	Max. Range (mm)	Max. Range (in)
Sort ▲ ▼		Sort ▲ ▼	Sort ▲ ▼	Sort ▲ ▼	Sort ▲ ▼	Sort ▲ ▼	Sort ▲ ▼
CX-411		Thru-beam	Light-ON/Dark-ON	NPN	Red LED	10000	393.7
CX-411-J		Thru-beam, M12 Quick Disconnect	Light-ON/Dark-ON	NPN	Red LED	10000	393.7
CX-411-P		Thru-beam	Light-ON/Dark-ON	PNP	Red LED	10000	393.7

CX-422-Z		Diffuse Reflective, M8 Quick Disconnect	Light-ON/Dark-ON	NPN	Infrared LED	800	31.496
CX-423		Diffuse Reflective - Narrow-View	Light-ON/Dark-ON	NPN	Red LED	200	7.9
CX-423-J		Diffuse Reflective - Narrow-View, M12 Quick Disconnect	Light-ON/Dark-ON	NPN	Red LED	200	7.9
CX-423-P		Diffuse Reflective - Narrow-View	Light-ON/Dark-ON	PNP	Red LED	200	7.9
CX-423-P-J		Diffuse Reflective - Narrow-View. M12 Quick Disconnect	Light-ON/Dark-ON	PNP	Red LED	200	7.9
CX-423-P-Z		Diffuse Reflective - Narrow-View, M8 Quick Disconnect	Light-ON/Dark-ON	PNP	Red LED	200	7.9
CX-423-Z		Diffuse Reflective - Narrow-View, M8 Quick Disconnect	Light-ON/Dark-ON	NPN	Red LED	200	7.9
CX-424		Diffuse Reflective	Light-ON/Dark-ON	NPN	Infrared LED	100	3.6
CX-424-J		Diffuse Reflective, M12 Quick Disconnect	Light-ON/Dark-ON	NPN	Infrared LED	100	3.6
CX-424-P		Diffuse Reflective	Light-ON/Dark-ON	PNP	Infrared LED	100	3.6
CX-424-P-J		Diffuse Reflective, M12 Quick Disconnect	Light-ON/Dark-ON	PNP	Infrared LED	100	3.6
CX-424-P-Z		Diffuse Reflective, M8 Quick Disconnect	Light-ON/Dark-ON	PNP	Infrared LED	100	3.6
CX-424-Z		Diffuse Reflective, M8 Quick Disconnect	Light-ON/Dark-ON	NPN	Infrared LED	100	3.6
CX-441		Diffuse Reflective - FGS/BGS	Light-ON/Dark-ON	NPN	Red LED	50	1.97
CX-441-P		Diffuse Reflective - FGS/BGS	Light-ON/Dark-ON	PNP	Red LED	50	1.97
CX-441-P-Z		Diffuse Reflective - FGS/BGS, M8 Quick Disconnect	Light-ON/Dark-ON	PNP	Red LED	50	1.97
CX-441-Z		Diffuse Reflective - FGS/BGS, M8 Quick Disconnect	Light-ON/Dark-ON	NPN	Red LED	50	1.97
CX-442		Diffuse Reflective - FGS/BGS	Light-ON/Dark-ON	NPN	Red LED	300	11.8

DIMENSIONS (Unit: mm in)

CX-41□ Sensor

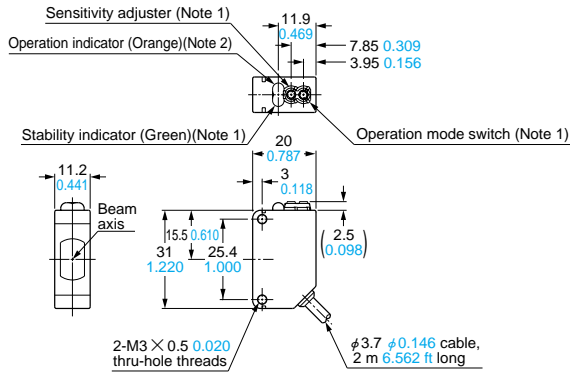

Notes: 1) Not incorporated on the emitter.
2) It is the power indicator (green) on the emitter.

CX-41□-Z Sensor

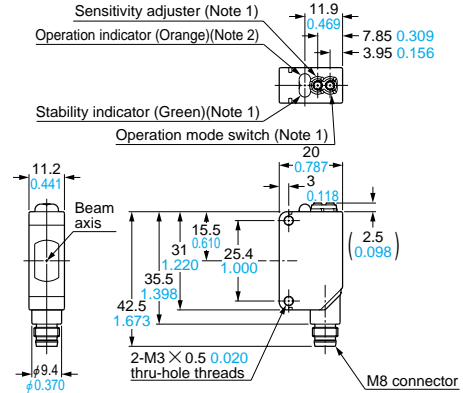

Notes: 1) Not incorporated on the emitter.
2) It is the power indicator (green) on the emitter.

CX-41□-J Sensor

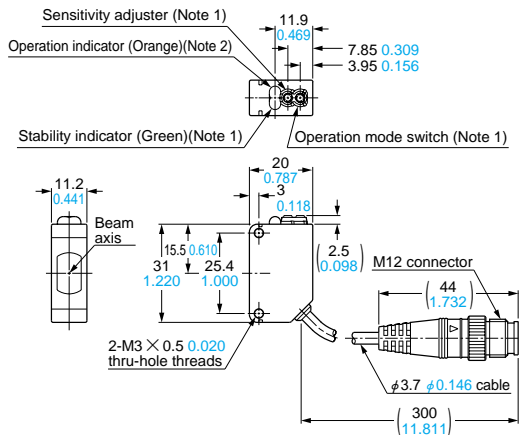

Notes: 1) Not incorporated on the emitter.
2) It is the power indicator (green) on the emitter.

CX-49□ CX-48□ CX-42□ Sensor

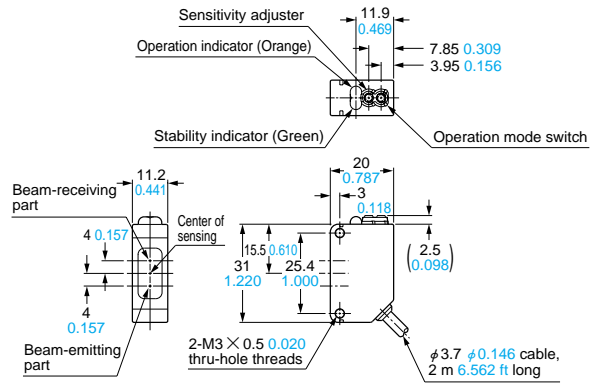

CX-49□-Z CX-48□-Z CX-42□-Z Sensor

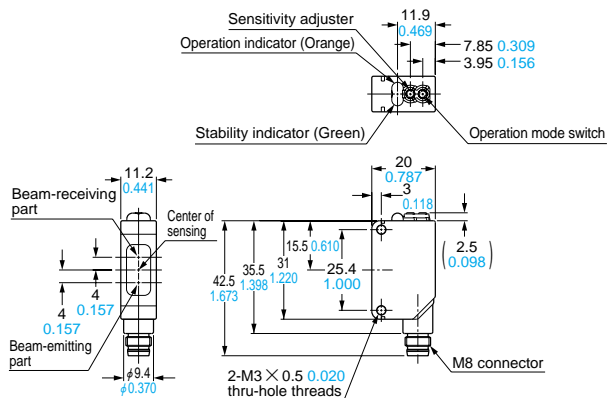

CX-49□-J CX-48□-J CX-42□-J Sensor

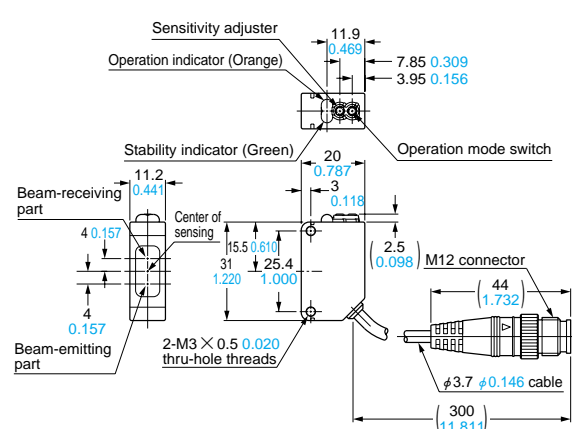

DIMENSIONS (Unit: mm in)

CX-44 Sensor

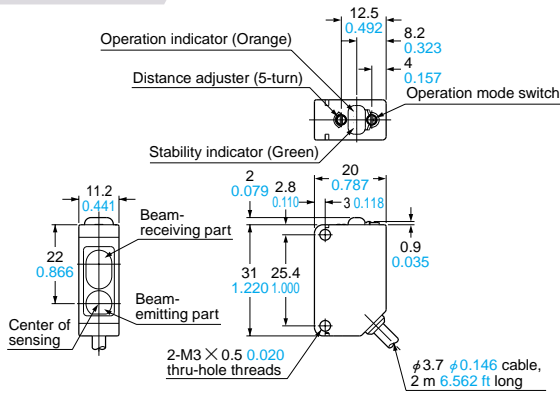

CX-44-Z Sensor

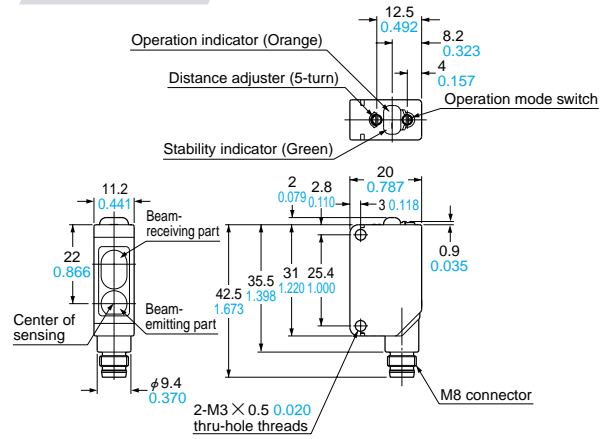

RF-230 Reflector
(Accessory for the retroreflective type sensor)

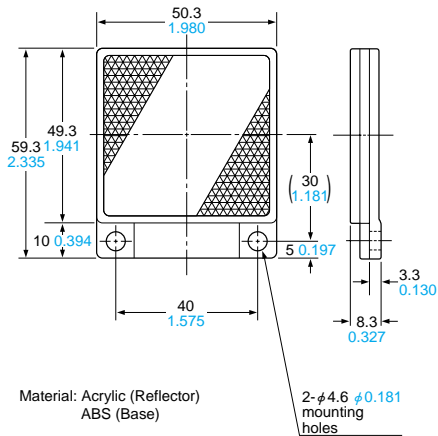

RF-220 Reflector (Optional)

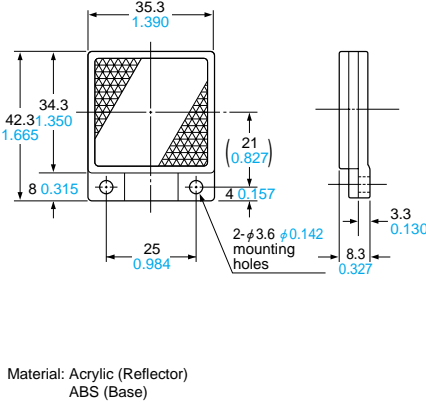

RF-210 Reflector (Optional)

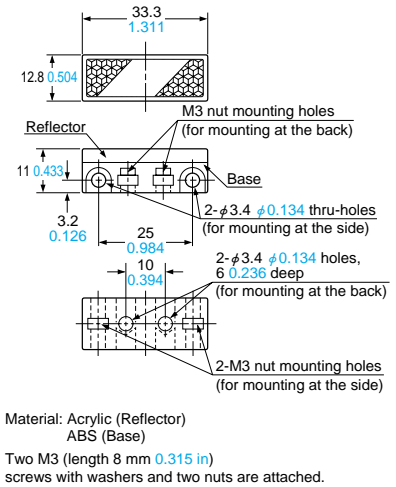

RF-11 Reflective tape (Optional)

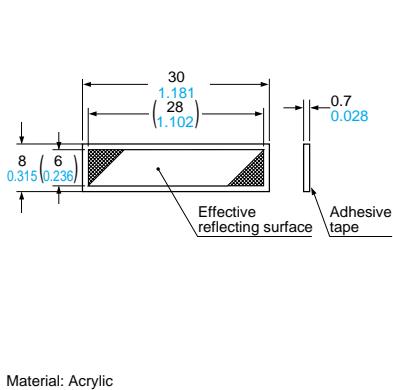

RF-12 Reflective tape (Optional)

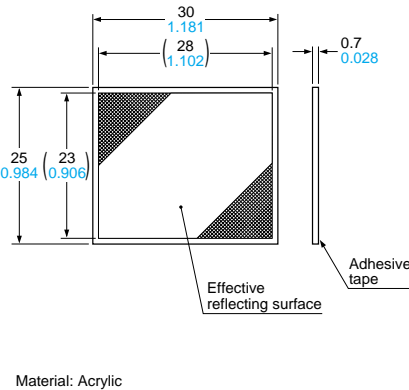

RF-13 Reflective tape (Optional)

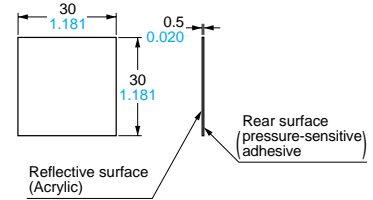

SPECIFICATIONS

Item	Model No.	Type	Thru-beam		Retroreflective				Diffuse reflective				
			Long sensing range		With polarizing filters	Long sensing range		For transparent object sensing					Narrow-view
			NPN output	CX-411	CX-412	CX-491	CX-493	CX-481	CX-482	CX-424	CX-421	CX-422	CX-423
PNP output	CX-411-P	CX-412-P	CX-491-P	CX-493-P	CX-481-P	CX-482-P	CX-424-P	CX-421-P	CX-422-P	CX-423-P			
Sensing range			10 m 32.808 ft	15 m 49.213 ft	3 m 9.843 ft (Note 1)	5 m 16.404 ft (Note 1)	50 to 500 mm 1.969 to 19.685 in (Note 1)	0.1 to 2 m 0.328 to 6.562 ft (Note 1)	100 mm 3.937 in (Note 2)	300 mm 11.811 in (Note 2)	800 mm 31.496 in (Note 2)	70 to 200 mm 2.756 to 7.874 in (Note 2)	
Sensing object			φ 12 mm φ 0.472 in or more opaque object (Note 3)	φ 50 mm φ 1.969 in or more opaque, translucent or specular object (Note 1)	φ 50 mm φ 1.969 in or more opaque or translucent object (Note 1)	φ 50 mm φ 1.969 in or more transparent, translucent or opaque object (Note 1)		Opaque, translucent or transparent object			Opaque, translucent or transparent object (Min. sensing object: φ 0.5 mm φ 0.020 in copper wire)		
Hysteresis									15 % or less of operation distance				
Repeatability (perpendicular to sensing axis)			0.5 mm 0.020 in or less						1 mm 0.039 in or less			0.5 mm 0.020 in or less	
Supply voltage			12 to 24 V DC ± 10 % Ripple P-P 10 % or less										
Current consumption			Emitter: 20 mA or less Receiver: 20 mA or less	Emitter: 25 mA or less Receiver: 20 mA or less	20 mA or less		25 mA or less	25 mA or less			20 mA or less		
Output			<NPN output type> NPN open-collector transistor • Maximum sink current: 100 mA • Applied voltage: 30 V DC or less (between output and 0 V) • Residual voltage: 1 V or less (at 100 mA sink current) 0.4 V or less (at 16 mA sink current)				<PNP output type> PNP open-collector transistor • Maximum source current: 100 mA • Applied voltage: 30 V DC or less (between output and + V) • Residual voltage: 1 V or less (at 100 mA source current) 0.4 V or less (at 16 mA source current)						
Output operation			Switchable either Light-ON or Dark-ON										
Short-circuit protection			Incorporated										
Response time			1 ms or less										
Operation indicator			Orange LED (lights up when the output is ON)(incorporated on the receiver for thru-beam type)										
Stability indicator			Green LED (lights up under stable light received condition or stable dark condition)(incorporated on the receiver for thru-beam type)										
Power indicator			Green LED (lights up when the power is ON) (incorporated on the emitter)										
Sensitivity adjuster			Continuously variable adjuster (incorporated on the receiver for thru-beam type)										
Automatic interference prevention function			Two units of sensors can be mounted close together with interference prevention filters. (Sensing range: 5 m 16.404 ft)		Incorporated (Two units of sensors can be mounted close together.)								
Environmental resistance	Protection		IP67 (IEC)										
	Ambient temperature		- 25 to + 55 °C - 13 to + 131 °F (No dew condensation or icing allowed), Storage: - 30 to + 70 °C - 22 to + 158 °F										
	Ambient humidity		35 to 85 % RH, Storage: 35 to 85 % RH										
	Ambient illuminance		Sunlight: 10,000 lx at the light-receiving face, Incandescent light: 3,000 lx at the light-receiving face										
	EMC		EN 60947-5-2										
	Voltage withstandability		1,000 V AC for one min. between all supply terminals connected together and enclosure										
	Insulation resistance		20 MΩ, or more, with 250 V DC megger between all supply terminals connected together and enclosure										
	Vibration resistance		10 to 500 Hz frequency, 1.5 mm 0.059 in double amplitude (10 G max.) in X, Y and Z directions for two hours each										
	Shock resistance		500 m/s ² acceleration (50 G approx.) in X, Y and Z directions for three times each										
Emitting element (modulated)			Red LED	Infrared LED	Red LED		Infrared LED			Red LED			
Material			Enclosure: PBT (polybutylene terephthalate), Lens: acrylic (CX-48□: polycarbonate), Front cover: acrylic (CX-48□: polycarbonate)										
Cable			0.2 mm ² 3-core (thru-beam type emitter: 2-core) cabtyre cable, 2 m 6.562 ft long										
Cable extension			Extension up to total 100 m 328.084 ft is possible with 0.3 mm ² , or more, cable (thru-beam type: both emitter and receiver)										
Weight			50 g approx. (Emitter of thru-beam type: 45 g approx.)										
Accessories			RF-230 (Reflector): 1 pc.										

Notes: 1) The sensing range and the sensing object of the retroreflective type sensor are specified for the RF-230 reflector. The sensing range represents the actual sensing range of the sensor. The sensing ranges itemized in 'A' of the table below may vary depending on the shape of sensing object. Be sure to check the operation with the actual sensing object.

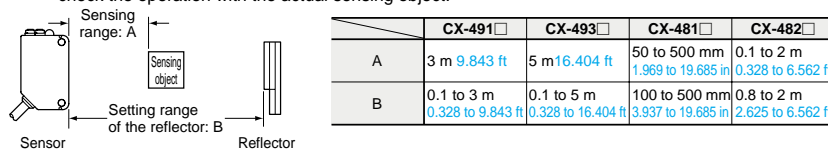

- The sensing range of the diffuse reflective type sensor is specified for white non-glossy paper (200 × 200 mm 7.874 × 7.874 in) as the object.
- If slit masks (optional) are fitted, an object of φ 0.5 mm φ 0.020 in (using round slit mask) can be detected.

SPECIFICATIONS

Item	Model No.	Type	Adjustable range reflective			
			Small spot	CX-443	CX-444	CX-442
		NPN output	CX-441	CX-443	CX-444	CX-442
		PNP output	CX-441-P	CX-443-P	CX-444-P	CX-442-P
Adjustable range (Note 1)			20 to 50 mm 0.787 to 1.969 in		20 to 100 mm 0.787 to 3.937 in	40 to 300 mm 1.575 to 11.811 in
Sensing range (with white non-glossy paper)			2 to 50 mm 0.079 to 1.969 in		15 to 100 mm 0.591 to 3.937 in	20 to 300 mm 0.787 to 11.811 in
Hysteresis			2 % or less of operation distance			5 % or less of operation distance
Repeatability			Along sensing axis: 1 mm 0.039 in or less, Perpendicular to sensing axis: 0.2 mm 0.008 in or less (with white non-glossy paper)			
Supply voltage			12 to 24 V DC $\pm 10\%$ Ripple P-P 10 % or less			
Current consumption			25 mA or less			
Output		<NPN output type>	<PNP output type>			
		NPN open-collector transistor	PNP open-collector transistor			
		<ul style="list-style-type: none"> Maximum sink current: 100 mA Applied voltage: 30 V DC or less (between output and 0 V) Residual voltage: 1 V or less (at 100 mA sink current) 	<ul style="list-style-type: none"> Maximum source current: 100 mA Applied voltage: 30 V DC or less (between output and + V) Residual voltage: 1 V or less (at 100 mA source current) 			
	Output operation	Switchable either Detection-ON or Detection-OFF				
	Short-circuit protection	Incorporated				
Response time			1 ms or less			
Operation indicator			Orange LED (lights up when the output is ON)			
Stability indicator			Green LED (lights up under stable operating condition) (Note 2)			
Distance adjuster			5-turn mechanical adjuster			
Sensing mode			BGS / FGS functions Switchable with wiring of sensing mode selection input			
Automatic interference prevention function (Note 3)			Incorporated			
Environmental resistance	Protection		IP67 (IEC)			
	Ambient temperature		- 25 to + 55 °C - 13 to + 131 °F (No dew condensation or icing allowed), Storage: - 30 to + 70 °C - 22 to + 158 °F			
	Ambient humidity		35 to 85 % RH, Storage: 35 to 85 % RH			
	Ambient illuminance		Sunlight:10,000 lx at the light-receiving face, Incandescent light: 3,000 lx at the light-receiving face			
	EMC		EN 60947-5-2			
	Voltage withstandability		1,000 V AC for one min. between all supply terminals connected together and enclosure			
	Insulation resistance		20 M Ω , or more, with 250 V DC megger between all supply terminals connected together and enclosure			
	Vibration resistance		10 to 500 Hz frequency, 3 mm 0.118 in double amplitude in X, Y and Z directions for two hours each			
Shock resistance		500 m/s ² acceleration (50 G approx.) in X, Y and Z directions for three times each				
Emitting element			Red LED (modulated)			
Spot diameter			ϕ 2 mm ϕ0.079 in approx. (at 50 mm 1.969 in distance)	ϕ 6.5 mm ϕ0.256 in approx. (at 50 mm 1.969 in distance)	ϕ 9 mm ϕ0.354 in approx. (at 100 mm 3.937 in distance)	\square 15 mm \square0.591 in approx. (at 300 mm 11.811 in distance)
Material			Enclosure: PBT (Polybutylene terephthalate), Front cover: Polycarbonate, Indicator cover: Polycarbonate			
Cable			0.2 mm ² 4-core cabtyre cable, 2 m 6.562 ft long			
Cable extension			Extension up to total 100 m 328.084 ft is possible with 0.3 mm ² , or more, cable.			
Weight			55 g approx.			

- Notes: 1) The adjustable range stands for the maximum sensing range which can be set with the distance adjuster. The sensor can detect an object 2 mm **0.079 in [CX-444(-P): 15 mm 0.591 in, CX-442(-P): 20 mm 0.787 in]**, or more, away.
 2) Refer to 'Stability indicator' (p.24) of 'PRECAUTIONS FOR PROPER USE' for the details of operation indicator.
 3) Note that detection may be unstable depending on the mounting conditions or the sensing object. In the state that this product is mounted, be sure to check the operation with the actual sensing object.

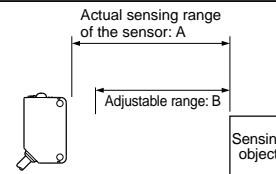

	CX-441□/443□	CX-444□	CX-442□
A	2 to 50 mm 0.079 to 1.969 in	15 to 100 mm 0.591 to 3.937 in	20 to 300 mm 0.787 to 11.811 in
B	20 to 50 mm 0.787 to 1.969 in	20 to 100 mm 0.787 to 3.937 in	40 to 300 mm 1.575 to 11.811 in