

ZMS Series Subminiature Snap-acting Switches (Dust Proof)



Features/Benefits

- Reliable snap-acting mechanism
- Long electrical and mechanical life
- Compact size—Ideal when space is limited
- Various PCB terminals and actuators
- RoHS compatible
- IP67 on some models

Typical Applications

- PCB detection switch
- Communication devices
- Testing equipment
- Security/Alarm systems
- Consumer electronics



Specifications

CONTACT RATING: 3A@ 125 V AC/ 3A@ 12 V DC, 10 mA@ 12 V DC.
 ELECTRICAL LIFE: 300,000 cycles @ 10mA / 100,000 cycles @
 3A,12V DC, 6,000 cycles @ 3A, 125 VAC
 INSULATION RESISTANCE: 100 M ohm min.
 DIELECTRIC STRENGTH: 500 Vrms.
 OPERATING TEMPERATURE: -40°C to 85°C.
 OPERATING FORCE: 80 or 130 grams.

* Low Level—conditions where no arcing occurs during switching, i.e., 0.4 VA max.
 @ 20 V AC or DC max.

Materials

CASE: Nylon
 COVER/ACTUATOR: PBT
 MOVABLE CONTACTS: Silver or gold plated.
 STATIONARY CONTACTS: Silver or gold plated.
 TERMINALS: Brass, tin plated.
 LEVER: Stainless steel

NOTE: Specifications and materials listed above are for switches with standard options.
 For information on specific and custom switches, consult Customer Service Center.

Build-A-Switch

To order, simply select desired option from each category and place in the appropriate box. Available options are shown and described on pages K-40 and K-42. For additional options not shown in catalog, consult Customer Service Center.

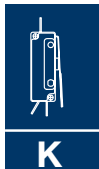
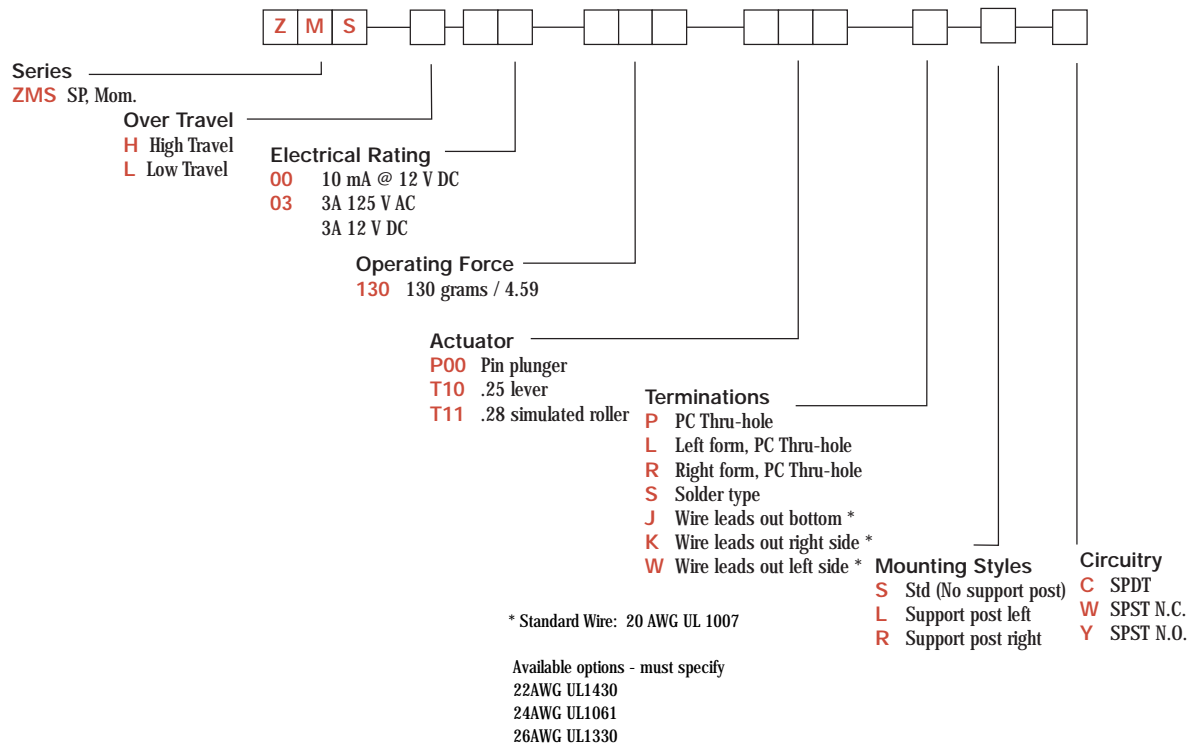

K

Snap-acting



Dimensions are shown: Inch (mm)
 Specifications and dimensions subject to change

ZMS Series Subminiature Snap-acting Switches

SERIES ZMS ■ ■ ■ ■ ■ ■ ■ ■ ■ ■

ZMSH HIGH OVER TRAVEL

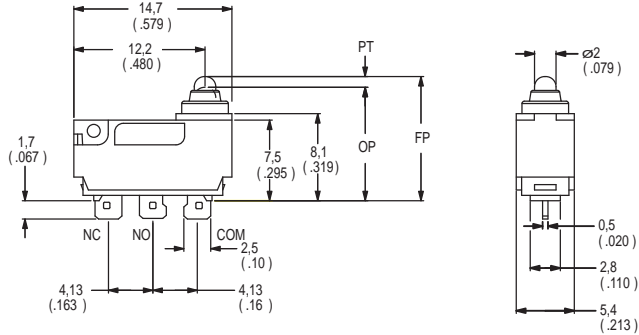

ZMSL LOW OVER TRAVEL

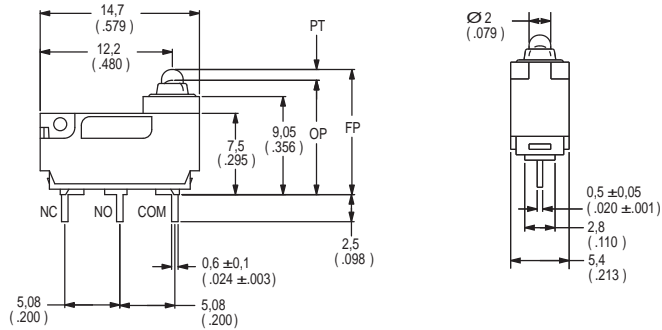

K

Snap-acting

ELECTRICAL RATING ■ ■ ■ ■ ■ ■ ■ ■ ■ ■

OPTION CODE	RoHS COMPLIANT*	RoHS COMPATIBLE*	CONTACT MATERIAL		ELECTRICAL RATING	
			MOVABLE CONTACT	STATIONARY CONTACT		
00	Yes	Yes	Gold over fine silver	Gold over fine silver	10mA @ 12 V DC	
03	Yes	Yes	Fine Silver	Fine silver	3 AMPS @ 125 V AC 3 AMPS @ 12 V DC	

* Note: See Technical Data in section N of this catalog for RoHS compliant and compatible definition and specifications.

Model with option "S" (solder type) only.
Consult Customer Service center for availability and delivery of nonstandard ratings.
*Electrical rating 03A is not available with Operating Force rating of 080.

OPERATING FORCE ■ ■ ■ ■ ■ ■ ■ ■ ■ ■

OPTION CODE	BASIC SWITCH OPERATING FORCE (OZ./GRAMS)
130	130 4.59



Dimensions are shown: Inch (mm)
Specifications and dimensions subject to change

www.ck-components.com

ZMS Series Subminiature Snap-acting Switches (Dust Proof)

ACTUATOR

P00 PIN PLUNGER

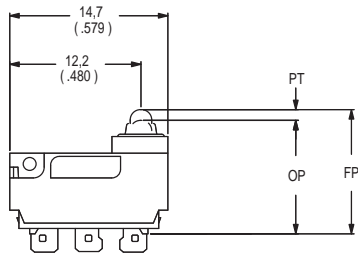

T10 .25 LEVER

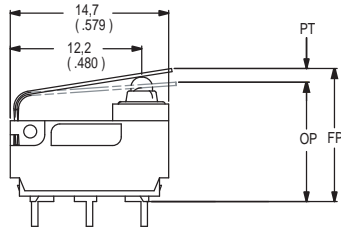

T11 LEVER

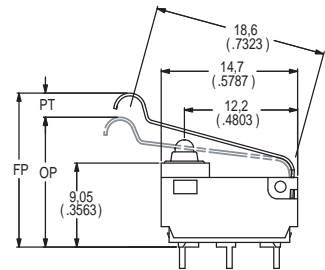

SWITCH CHARACTERISTICS

Actuator code	Maximum Operate Force (grams/oz.)	Minimum Release Force (grams/oz.)	Free Position Max	Maximum Pre-travel	Operate Position	Maximum Differential	Minimum Overtravel
P00	130 4.59	13 0.45	.439 (11.15)	0.032 (0,8)	.415+/- .008 (10.55+/- .2)	.008 (0,2)	0.031 (0,8)
T10	195 6.88	55 1.93	.570 (14.5)	0.152 (3,85)	.440+/- .020 (11.2+/- .5)	0.020 (0,5)	0.053 (1,35)
T11	160 5.64	45 1.58	.693 (17.6)	0.186 (4,8)	.539+/- .032 (13.7+/- .8)	0.030 (0,7)	0.062 (1,65)

P00 PIN PLUNGER

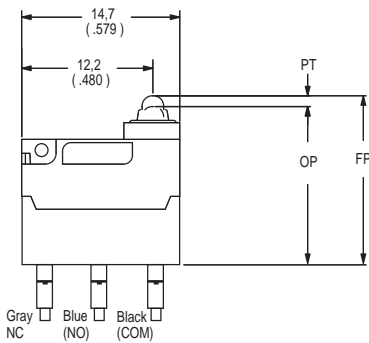

T10 .25 LEVER

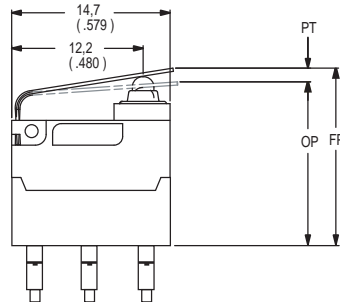

T11 .28 LEVER

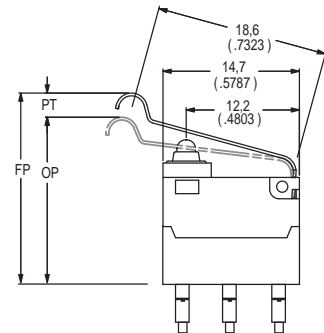

SWITCH CHARACTERISTICS "J" TERMINATION ONLY

Actuator code	Maximum Operate Force (grams/oz.)	Minimum Release Force (grams/oz.)	Free Position Max	Maximum Pre-travel	Operate Position	Maximum Differential	Minimum Overtravel
P00	130 4.59	13 0.45	.616 (15.65)	0.032 (0,8)	.593+/- .008 (15.05+/- .2)	.008 (0,2)	0.031 (0,8)
T10	195 6.88	55 1.93	.747 (19.0)	0.152 (3,85)	.617+/- .020 (20.2+/- .5)	0.020 (0,5)	0.053 (1,35)
T11	160 5.64	45 1.58	.870 (22.1)	0.188 (4,8)	.716+/- .032 (18.2+/- .8)	0.030 (0,7)	0.062 (1,65)



Dimensions are shown: Inch (mm)
Specifications and dimensions subject to change



Snap-acting

ZMS Series Subminiature Snap-acting Switches (Dust Proof)

TERMINATIONS

P PC THRU-HOLE

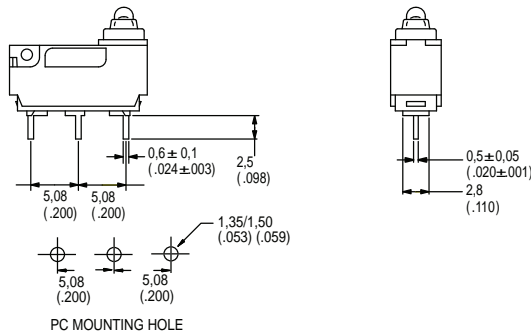

L LEFT FOOTED, PC THRU-HOLE

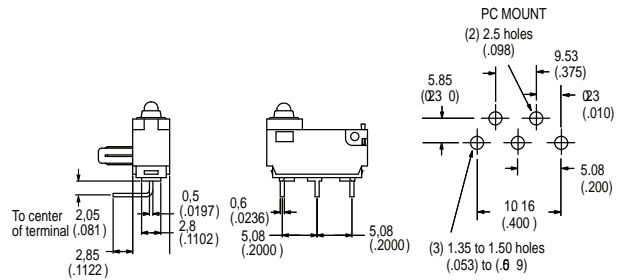

R RIGHT FOOTED, PC THRU-HOLE

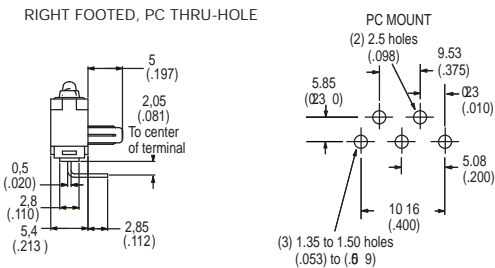

J WIRE LEADS BOTTOM (IP67)

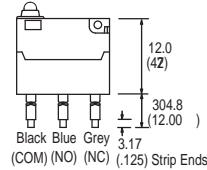

K RIGHT SIDE (IP67)

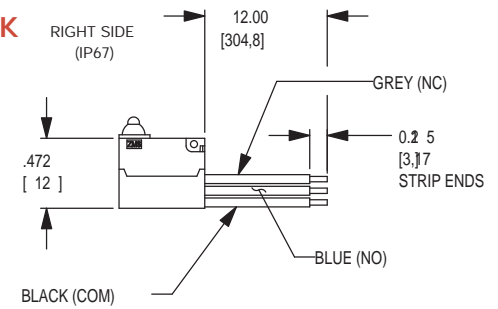

S SOLDER TYPE

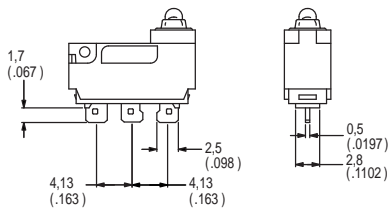

W LEFT SIDE (IP67)

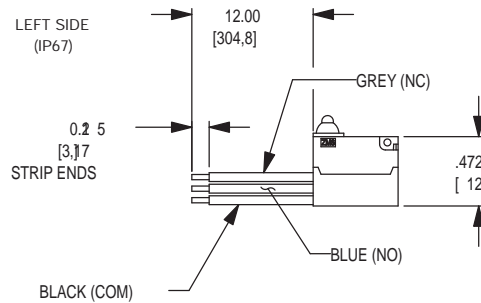

Standard Wire: 20 AWG UL 1007

Available options - must specify
22AWG UL1430
24AWG UL1061
26AWG UL1330

MOUNTING STYLES

S STD (NO SUPPORT POST)

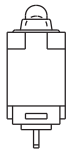

L SUPPORT POST LEFT

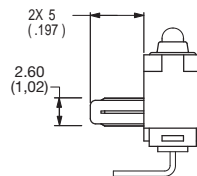

R SUPPORT POST RIGHT

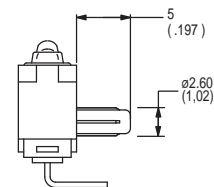

CIRCUITRY

C SPDT (Single Pole, Double Throw)

W SPST, NC (Single Pole, Single Throw, Normally Closed)

Y SPST, NO (Single Pole, Single Throw, Normally Open)

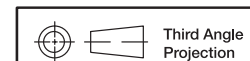

Third Angle
Projection

Dimensions are shown: Inch (mm)
Specifications and dimensions subject to change



www.ck-components.com