



Electromechanical counter housed in standard CYCL-FLEX® case



The HZ170 series is an electromechanical counter housed in the standard CYCL-FLEX® case. The unit is available in three count ranges, 12, 40, and 100. The count setpoint is adjustable by a knob on the front of the unit.

Its features include:

- All count ranges use solenoid operated pawl feed count motor and electromechanical clutch
- Progress pointer, indicating count progression, advances clockwise from setpoint to zero
- Two sets of SPDT instantaneous contacts and two delayed SPDT switches which transfer at count out control output sequences
- Instantaneous and delayed contacts may be interconnected to supply output sequences
- Optional reverse action clutch will not reset on power failure

OPERATION

The HZ170 series counter is an impulse motor driven unit with standard or reverse clutch operation.

When power is applied to the clutch terminals on standard units, the clutch engages and instantaneous contacts transfer enabling the counter to receive and register counts. A 40 ms pulse to the count motor will register a count by moving the count progress pointer toward the zero point on the dial. When the progress pointer reaches zero, the unit is counted out and a set of delayed switches transfer. Additional counts will not be registered until the unit is reset. Removal of power from the clutch terminals resets the counter.

Units with 40 count and 100 count ranges have two delayed action switches. By adjustment of set screws on the switch trip lever, a transfer differential between the two switches can be obtained. The 40 count range switch differential can be adjusted for one count early transfer before count out. The 100 count range differential is two counts.

On reverse action clutch operation, removal of power from the clutch terminals enables the counter to receive counts.

SPECIFICATIONS

Count Ranges:

Sym.	Count Range	Minimum Setting
0	2-100	2
1	1-12	1
2	1-40	1

Count Speed: 500 counts per min. max.

Accuracy: 100%

Reset Time: 500 ms at max. setting

Input Requirements: Stepping Motor: 40 ms "ON" time, 80 ms "OFF" time
Clutch Coil: 50 ms pull in

Voltage/Frequency: 120 VAC (+10, -15%), 50/60 Hz
240 VAC (+10, -15%), 50/60 Hz

Burden: Stepping Motor: 26 VA, Inrush
Clutch Coil: 16 VA, Inrush; 10.5 VA, Maintained

Output Rating: 10 amps, 120 V, 50/60 Hz
5 amps, 240 V, 50/60 Hz

Temperature Range: 0° to 140°F (-18° to +60°C)

Laboratory Testing: UL Recognition E96337
CSA Certification LR26861

ENCLOSURES

Model No.	NEMA Class	Description
HN308	1	Surface Mtg. with terminal block
HN364	1	Surface Mtg. without terminal block
HN370	1A	Dual unit cabinet less unit cases and toggle switch, with 9 terminal block

ACCESSORIES

Model No.	Description
H-5331	Mounting Brackets 2 req'd per timer
HP50-31	One Hole Mounting Ring
HP103	120 V, 50/60 Hz Repeat Cycle Kit Not available with Feature 02
HP105	240 V, 50/60 Hz Repeat Cycle Kit Not available with Feature 02
HP50-133	Surface Mounting Adapter to use in place of brackets
HZ170-121	Dial Lock

MOUNTING

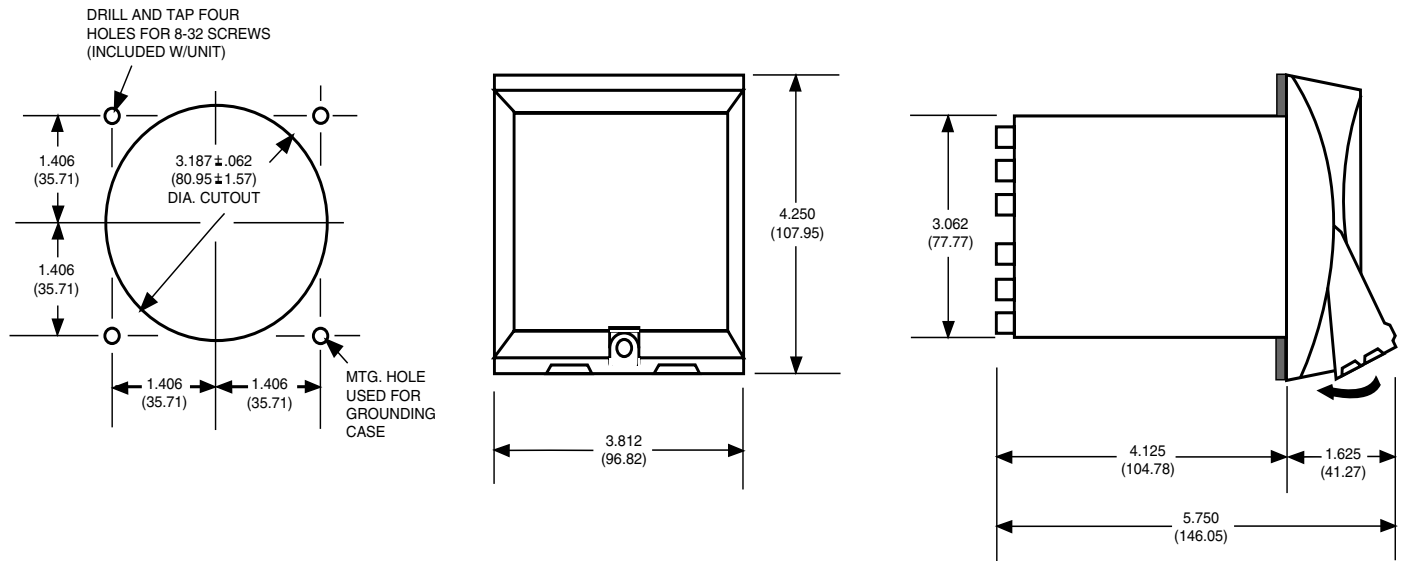

ORDERING INFORMATION

HZ17 0 A6 01

Sym.	Description
0	2-100
1	1-12
2	1-40

Sym.	Description
A6	120 VAC, 50/60 Hz
B5	240 VAC, 50 Hz
B6	240 VAC, 60 Hz

Sym.	Description
01	Reverse Clutch
02	Revised for Mounting in NEMA VII Explosion Proof Enclosure HN384
05	Chrome Plated Bezel
07	Dial Lock
92	Enclosed in HN384 Explosion Proof Cabinet