

NTE272 (NPN) & NTE273 (PNP) Silicon Darlington Complementary Power Amplifiers

Description:

The NTE272 (NPN) and NTE273 (PNP) are silicon complementary Power Amplifiers in a TO202 type case designed for use in complementary amplifiers and driver applications.

Features:

- High DC Current Gain:
 $h_{FE} = 25,000$ (Min) @ $I_C = 200\text{mA}$
 $= 15,000$ (Min) @ $I_C = 500\text{mA}$
- Collector–Emitter Breakdown Voltage:
 $V_{(BR)CES} = 40\text{V}$ @ $I_C = 500\text{mA}$
- Low Collector–Emitter Saturation Voltage:
 $V_{CE(sat)} = 1.5\text{V}$ @ $I_C = 1\text{A}$
- Monolithic Construction for High Reliability

Absolute Maximum Ratings:

Collector–Emitter Voltage (Note 2), V_{CEO}	40V
Collector–Emitter Voltage, V_{CES}	40V
Collector–Base Voltage, V_{CB}	50V
Emitter–Base Voltage, V_{EB}	12V
Collector Current, I_C	2A
Total Power Dissipation ($T_A = +25^\circ\text{C}$), P_D	1W
Derate above 25°C	8mW/ $^\circ\text{C}$
Total Power Dissipation ($T_C = +25^\circ\text{C}$), P_D	10W
Derate above 25°C	80mW/ $^\circ\text{C}$
Operating Junction Temperature Range, T_J	-55 to $+150^\circ\text{C}$
Storage Temperature Range, T_{stg}	-55 to $+150^\circ\text{C}$
Thermal Resistance, Junction–to–Ambient, R_{thJA}	125 $^\circ\text{C}/\text{W}$
Thermal Resistance, Junction–to–Case, R_{thJC}	12.5 $^\circ\text{C}/\text{W}$

Note 1. **NTE273** is a **discontinued** device and **no longer** available.

Note 2. Due to the monolithic construction of this device, breakdown voltages of both transistor elements are identical. $V_{(BR)CES}$ is tested in lieu of $V_{(BR)CEO}$ in order to avoid errors caused by noise pickup. The voltage measured during the $V_{(BR)CES}$ test is the $V_{(BR)CEO}$ of the output transistor.

Electrical Characteristics: ($T_A = +25^\circ\text{C}$ unless otherwise specified)

Parameter	Symbol	Test Conditions	Min	Typ	Max	Unit
OFF Characteristics						
Collector-Emitter Breakdown Voltage	$V_{(BR)CES}$	$I_C = 100\mu\text{A}, V_{BE} = 0$	40	-	-	V
Collector-Base Breakdown Voltage	$V_{(BR)CBO}$	$I_C = 100\mu\text{A}, I_E = 0$	50	-	-	V
Emitter-Base Breakdown Voltage	$V_{(BR)EBO}$	$I_E = 10\mu\text{A}, I_C = 0$	12	-	-	V
Collector Cutoff Current	I_{CBO}	$V_{CB} = 30\text{V}, I_E = 0$	-	-	100	nA
Emitter Cutoff Current	I_{EBO}	$V_{EB} = 10\text{V}, I_C = 0$	-	-	100	nA
ON Characteristics (Note 3)						
DC Current Gain	$ h_{fe} $	$I_C = 200\text{mA}, V_{CE} = 5\text{V}$	25,000	65,000	150,000	
		$I_C = 500\text{mA}, V_{CE} = 5\text{V}$	15,000	35,000	-	
		$I_C = 1\text{A}, V_{CE} = 5\text{V}$	4,000	12,000	-	
Collector-Emitter Saturation Voltage	$V_{CE(sat)}$	$I_C = 1\text{A}, I_B = 2\text{mA}$	-	1.2	1.5	V
Base-Emitter Saturation Voltage	$V_{BE(sat)}$	$I_C = 1\text{A}, I_B = 2\text{mA}$	-	1.85	2.0	V
Base-Emitter ON Voltage	$V_{BE(ON)}$	$I_C = 1\text{A}, V_{CE} = 5\text{V}$	-	1.7	2.0	V
Dynamic Characteristics						
Small-Signal Current Gain	h_{FE}	$I_C = 200\text{mA}, V_{CE} = 5\text{V}, f = 100\text{MHz}, \text{Note 2}$	1.0	3.2	-	
Collector-Base Capacitance	C_{cb}	$V_{CB} = 10\text{V}, I_E = 0, f = 1\text{MHz}$	-	2.5	6.0	pF

Note 3. Pulse test: Pulse Width $\leq 300\mu\text{s}$, Duty Cycle $\leq 2.0\%$.

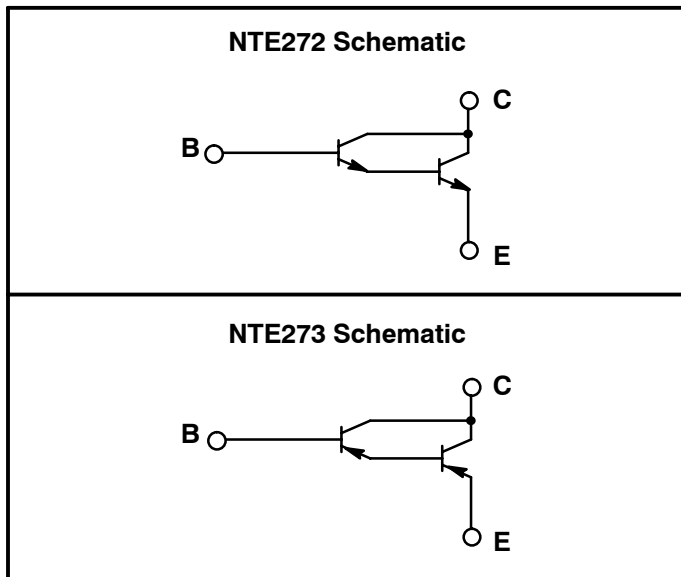

Uniwatt darlington transistors can be used in any number of low power applications, such as relay drivers, motor control and as general purpose amplifiers. As an audio amplifier these devices, when used as a complementary pair, can drive 3.5 watts into a 3.2ohm speaker using a 14 volt supply with less than one per cent distortion. Because of the high gain the base drive requirement is as low as 1mA in this application. They are also useful as power drivers for high current application such as voltage regulators.

