

93LC76/86

8K/16K 2.5V Microwire Serial EEPROM

Features:

- Single supply with programming operation down to 2.5V
- Low-power CMOS technology
 - 1 mA active current typical
 - 5 µA standby current (typical) at 3.0V
- ORG pin selectable memory configuration
1024 x 8 or 512 x 16 bit organization (93LC76)
2048 x 8 or 1024 x 16 bit organization (93LC86)
- Self-timed erase and write cycles (including auto-erase)
- Automatic ERAL before WRAL
- Power on/off data protection circuitry
- Industry standard 3-wire serial I/O
- Device status signal during erase/write cycles
- Sequential read function
- 1,000,000 erase/write cycles ensured
- Data retention > 200 years
- 8-pin PDIP/SOIC package
- Temperature ranges available
 - Commercial (C) 0°C to +70°C
 - Industrial (I) -40°C to +85°C

Description:

The Microchip Technology Inc. 93LC76/86 are 8K and 16K low voltage serial Electrically Erasable PROMs. The device memory is configured as x8 or x16 bits depending on the ORG pin setup. Advanced CMOS technology makes these devices ideal for low power nonvolatile memory applications. These devices also have a Program Enable (PE) pin to allow the user to write-protect the entire contents of the memory array. The 93LC76/86 is available in standard 8-pin PDIP and 8-pin surface mount SOIC packages.

Package Types

PDIP Package

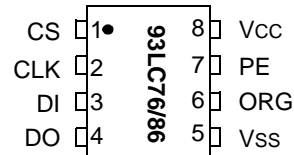

SOIC Package

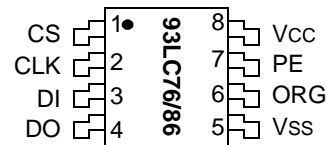

Block Diagram

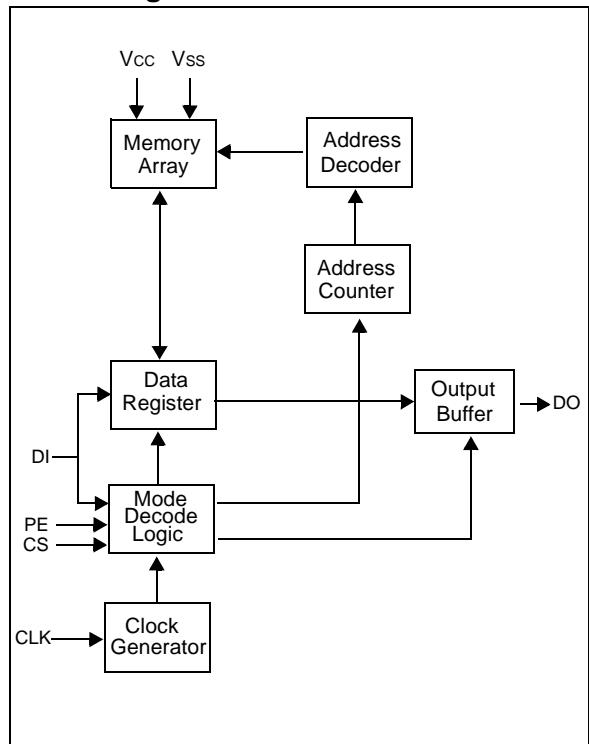

93LC76/86

1.0 ELECTRICAL CHARACTERISTICS

Absolute Maximum Ratings^(†)

V _{CC}	7.0V
All inputs and outputs w.r.t. V _{SS}	-0.6V to V _{CC} + 1.0V
Storage temperature	-65°C to +150°C
Ambient temperature with power applied.....	-40°C to +125°C
Soldering temperature of leads (10 seconds)	+300°C
ESD protection on all pins	4 kV

† NOTICE: Stresses above those listed under “Absolute Maximum Ratings” may cause permanent damage to the device. This is a stress rating only and functional operation of the device at these or any other conditions above those indicated in the operational listings of this specification is not implied. Exposure to Absolute Maximum Rating conditions for extended periods may affect device reliability.

1.1 AC Test Conditions

AC Waveform:

$$V_{LO} = 2.0V$$

$$V_{HI} = V_{CC} - 0.2V \quad \text{(Note 1)}$$

$$V_{HI} = 4.0V \text{ for} \quad \text{(Note 2)}$$

Timing Measurement Reference Level

Input 0.5 V_{CC}

Output 0.5 V_{CC}

Note 1: For V_{CC} ≤ 4.0V

2: For V_{CC} > 4.0V

TABLE 1-1: DC CHARACTERISTICS

DC CHARACTERISTICS					
Applicable over recommended operating ranges shown below unless otherwise noted: V _{CC} = +2.5V to +6.0V Commercial (C): T _A = 0°C to +70°C Industrial (I): T _A = -40°C to +85°C					
Parameter	Symbol	Min.	Max.	Units	Conditions
High-level input voltage	V _{IH1}	2.0	V _{CC} + 1	V	V _{CC} ≥ 2.7V
	V _{IH2}	0.7 V _{CC}	V _{CC} + 1	V	V _{CC} < 2.7V
Low-level input voltage	V _{IL1}	-0.3	0.8	V	V _{CC} ≥ 2.7V
	V _{IL2}	-0.3	0.2 V _{CC}	V	V _{CC} < 2.7V
Low-level output voltage	V _{OL1}	—	0.4	V	I _{OL} = 2.1 mA; V _{CC} = 4.5V
	V _{OL2}	—	0.2	V	I _{OL} = 100 μA; V _{CC} = V _{CC} Min.
High-level output voltage	V _{OH1}	2.4	—	V	I _{OH} = -400 μA; V _{CC} = 4.5V
	V _{OH2}	V _{CC} -0.2	—	V	I _{OH} = -100 μA; V _{CC} = V _{CC} Min.
Input leakage current	I _{LI}	-10	10	μA	V _{IN} = 0.1V to V _{CC}
Output leakage current	I _{LO}	-10	10	μA	V _{OUT} = 0.1V to V _{CC}
Pin capacitance (all inputs/outputs)	C _{INT}	—	7	pF	(Note 1) T _A = +25°C, F _{CLK} = 1 MHz
Operating current	I _{CC} write	—	3	mA	V _{CC} = 5.5V
	I _{CC} read	—	1 500	mA μA	F _{CLK} = 3 MHz; V _{CC} = 5.5V F _{CLK} = 1 MHz; V _{CC} = 3.0V
Standby current	I _{CCS}	—	100	μA	CLK = CS = 0V; V _{CC} = 5.5V
			30	μA	CLK = CS = 0V; V _{CC} = 3.0V DI = PE = V _{SS} ORG = V _{SS} or V _{CC}

Note 1: This parameter is periodically sampled and not 100% tested.

93LC76/86

TABLE 1-2: AC CHARACTERISTICS

Applicable over recommended operating ranges shown below unless otherwise noted: V _{CC} = +2.5V to +6.0V Commercial (C): T _A = 0°C to +70°C Industrial (I): T _A = -40°C to +85°C					
Parameter	Symbol	Min.	Max.	Units	Conditions
Clock frequency	FCLK	—	3	MHz	4.5V ≤ V _{CC} ≤ 6.0V
			2	MHz	2.5V ≤ V _{CC} < 4.5V
Clock high time	TCKH	200	—	ns	4.5V ≤ V _{CC} ≤ 6.0V
		300		ns	2.5V ≤ V _{CC} < 4.5V
Clock low time	TCKL	100	—	ns	4.5V ≥ V _{CC} ≤ 6.0V
		200		ns	2.5V ≤ V _{CC} < 4.5V
Chip select setup time	Tcss	50	—	ns	4.5V ≤ V _{CC} ≤ 6.0V, Relative to CLK
		100		ns	2.5V ≤ V _{CC} < 4.5V, Relative to CLK
Chip select hold time	Tcsh	0	—	ns	—
Chip select low time	TCSL	250	—	ns	Relative to CLK
Data input setup time	Tdis	50	—	ns	4.5V ≤ V _{CC} ≤ 6.0V, Relative to CLK
		100		ns	2.5V ≤ V _{CC} < 4.5V, Relative to CLK
Data input hold time	TDIH	50	—	ns	4.5V ≤ V _{CC} ≤ 6.0V, Relative to CLK
		100		ns	2.5V ≤ V _{CC} < 4.5V, Relative to CLK
Data output delay time	TPD	—	100	ns	4.5V ≤ V _{CC} ≤ 6.0V, C _L = 100 pF
			250	ns	2.5V ≤ V _{CC} < 4.5V, C _L = 100 pF
Data output disable time	TCZ	—	100	ns	4.5V ≤ V _{CC} ≤ 6.0V
			500	ns	2.5V ≤ V _{CC} < 4.5V (Note 1)
Status valid time	Tsv	—	200	ns	4.5V ≥ V _{CC} ≤ 6.0V, C _L = 100 pF
			300	ns	2.5V ≤ V _{CC} < 4.5V, C _L = 100 pF
Program cycle time	TWC	—	5	ms	Erase/Write mode
	TEC	—	15	ms	ERAL mode
	TWL	—	30	ms	WRAL mode
Endurance	—	1M	—	cycles	25°C, V _{CC} = 5.0V, Block mode (Note 2)

Note 1: This parameter is periodically sampled and not 100% tested.

2: This parameter is not tested but ensured by characterization. For endurance estimates in a specific application, please consult the Total Endurance™ Model which can be obtained from Microchip's web site at

93LC76/86

8-Lead Plastic Small Outline (SN) – Narrow, 150 mil Body (SOIC)

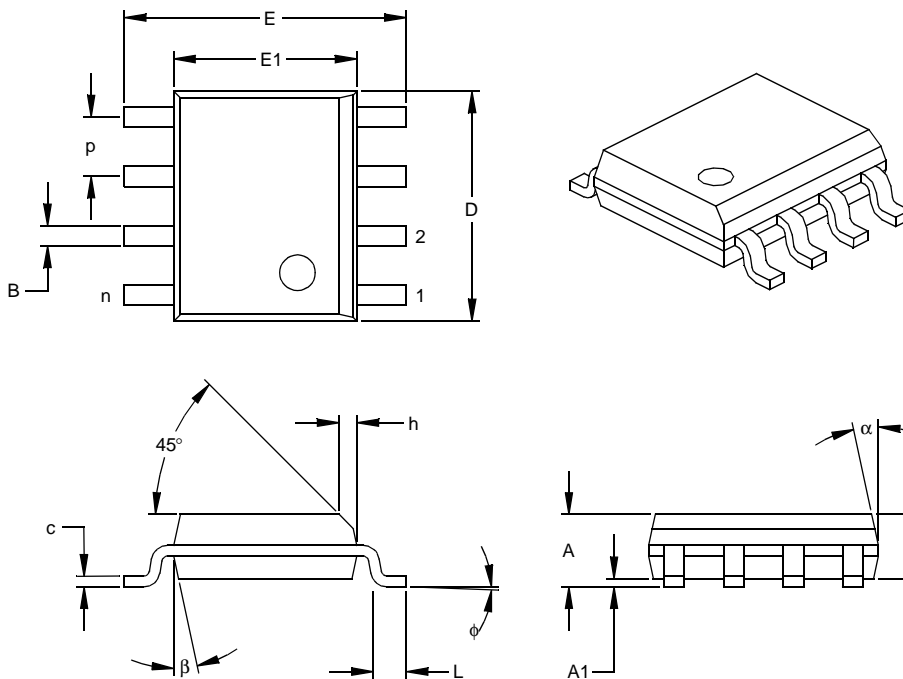

Dimension	Units	INCHES*			MILLIMETERS		
		MIN	NOM	MAX	MIN	NOM	MAX
Number of Pins	n	8			8		
Pitch	p		.050			1.27	
Overall Height	A	.053	.061	.069	1.35	1.55	1.75
Molded Package Thickness	A2	.052	.056	.061	1.32	1.42	1.55
Standoff §	A1	.004	.007	.010	0.10	0.18	0.25
Overall Width	E	.228	.237	.244	5.79	6.02	6.20
Molded Package Width	E1	.146	.154	.157	3.71	3.91	3.99
Overall Length	D	.189	.193	.197	4.80	4.90	5.00
Chamfer Distance	h	.010	.015	.020	0.25	0.38	0.51
Foot Length	L	.019	.025	.030	0.48	0.62	0.76
Foot Angle	φ	0	4	8	0	4	8
Lead Thickness	c	.008	.009	.010	0.20	0.23	0.25
Lead Width	B	.013	.017	.020	0.33	0.42	0.51
Mold Draft Angle Top	α	0	12	15	0	12	15
Mold Draft Angle Bottom	β	0	12	15	0	12	15

* Controlling Parameter
 § Significant Characteristic

Notes:
 Dimensions D and E1 do not include mold flash or protrusions. Mold flash or protrusions shall not exceed .010" (0.254mm) per side.
 JEDEC Equivalent: MS-012
 Drawing No. C04-057

PRODUCT IDENTIFICATION SYSTEM

To order or obtain information, e.g., on pricing or delivery, refer to the factory or the listed sales office.

<u>PART NO.</u>	<u>X</u>	<u>/XX</u>	<u>XXX</u>
Device	Temperature Range	Package	Pattern
Device	93LC76/86: Microwire Serial EEPROM 93LC76T/86T: Microwire Serial EEPROM (Tape and Reel)		
Temperature Range	Blank = 0°C to +70°C I = -40°C to +85°C		
Package	P = Plastic DIP (300 mil Body), 8-lead SN = Plastic SOIC (150 mil Body), 8-lead		