

Soft Start-up Valve AV2000/3000/4000/5000

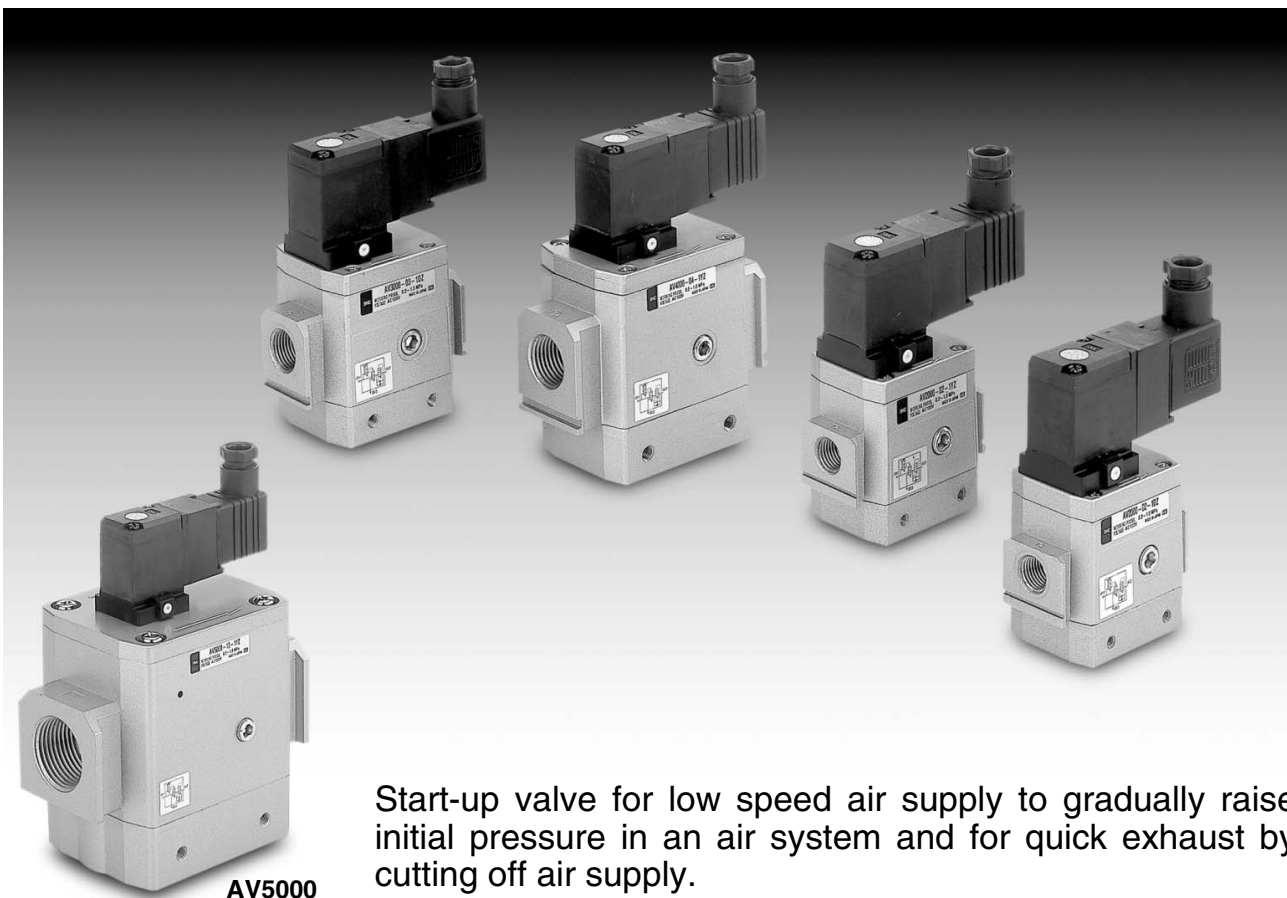

AV5000

Start-up valve for low speed air supply to gradually raise initial pressure in an air system and for quick exhaust by cutting off air supply.

F.R.L.

AV

AU

AF

AR

IR

VEX

AMR

ITV

IC

VBA

VE□

VY1

G

PPA

AL

Large effective area (mm²)

AV2000/ 20 (Body size: 1/4)

AV3000/ 37 (Body size: 3/8)

AV4000/ 61 (Body size: 1/2)

AV5000/ 113 (Body size: 3/4)

AV5000/ 122 (Body size: 1)

With supply/exhaust function by manual operation

Low power consumption

Connectable with modular type
F.R.L. combination unit

Combination with F.R.L. unit

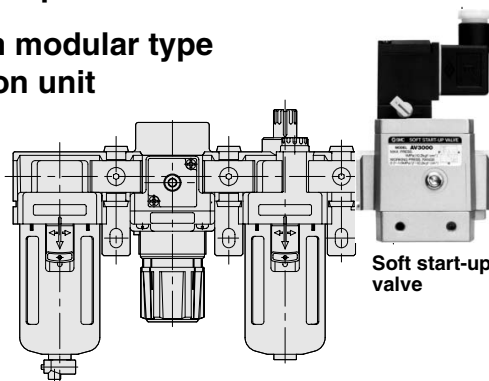
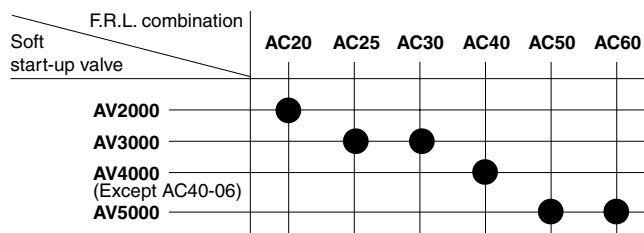

F.R.L. combination

Soft start-up valve

⚠ Precautions

Be sure to read before handling. Refer to pages 14-21-3 to 14-21-4 for Safety Instructions and Common Precautions.

Caution on Design

⚠ Warning

1. Actuator drive

When using solenoid valve or actuator in the outlet side of this product, implement appropriate measures to prevent potential danger caused by actuator operation.

2. Holding pressure

Since the valve might have slight interal leakage, it is not suitable for holding pressure in a tank or another vessel for a long period of time.

3. Maintenance space

Allow the sufficient space for maintenance and inspection.

Selection

⚠ Warning

1. Confirm the specifications.

The products presented in this catalog are designed only for use in compressed air systems. Do not operate at pressures or temperatures, etc., beyond the range of specifications, as this can cause damage or malfunction. (Refer to specifications.) Please contact SMC if using for other fluids than compressed air.

2. Extended periods of continuous energization

Please contact SMC if valves will be continuously energized for extended periods of time.

3. Operation of closed center solenoid valves

Even if this product is used for closed center solenoid valves or actuator with a load factor of more than 50%, jumping (stick-slip phenomenon) cannot be prevented.

4. Using a regulator in the outlet side

When mounting a regulator in the outlet side (A port side), use a residual pressure relief regulator (AR25K to 40K) or a check type regulator. With a standard regulator (AR10 to 60), the outlet side pressure may not be released when this valve is exhausted.

5. Operation of solenoid valves in the outlet side

To operate solenoid valves mounted on this product's outlet side (A port side), first confirm that the outlet side's pressure (P) has increased to become equal to the inlet side's pressure (P).

6. Operation

The residual pressure release function of this product is for emergency use only; therefore, avoid the operation in the same manner as ordinary 3 port valves.

7. Using a lubricator

If mounting a lubricator, mount it on the inlet side (P port side), of this product. If mounted on the outlet side (A port side), back flow of oil will occur and may spurt out of the valve's R port.

8. Operation for air blowing

This product cannot be operated for air blowing due to the mechanism that switches the main valve to be fully open after the outlet side's pressure increases to approximately 1/2 of the inlet side.

Selection

⚠ Caution

1. Voltage leakage

Particularly when using a C-R element (surge voltage suppressor) for protection of the switching element, use caution that leakage voltage will increase due to leakage current flowing through the C-R element, etc.

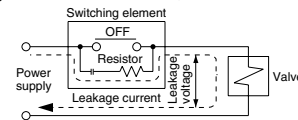

AC coil is 20% or less of rated voltage.

DC coil is 3% or less of rated voltage.

2. Low temperature operation

Although the valve can be operated at temperature as low as 0°C, measures should be taken to avoid solidifying or freezing drainage and moisture, etc.

Mounting

⚠ Warning

1. If air leakage increases or equipment does not operate properly, stop operation.

After mounting or maintenance, etc., connect the compressed air and power supplies, and perform appropriate function and leakage tests to confirm that the unit is mounted properly.

2. Instruction manual

Mount and operate the product after reading the manual carefully and understanding its contents. Also keep the manual in a place where it can be referred to as necessary.

3. Painting and coating

Warnings or specifications printed or labeled on a product should not be erased, removed or covered up. Furthermore, please contact SMC before painting the resin parts, as this may cause adverse effects depending on the solvent.

Adjustment

⚠ Caution

1. To perform the initial speed adjustment of a outlet side actuator, supply air from this valve's inlet side and turn ON the pilot valve. Then, rotate the needle clockwise from the fully closed position.

⚠ Precautions

Be sure to read before handling. Refer to pages 14-21-3 to 14-21-4 for Safety Instructions and Common Precautions.

Piping

⚠ Caution

1. Preparation before piping

Before piping is connected, it should be thoroughly blown out by air (flushed) or washed to eliminate cutting chips, cutting oil, and other debris from the pipe inside.

2. How to wrap a pipe tape

When connecting pipes and fittings, etc., ensure that cutting chips and sealing materials from the pipe threads should not get inside the valve. When a pipe tape is used, leave 1.5 to 2 thread ridges exposed at the end of the pipe.

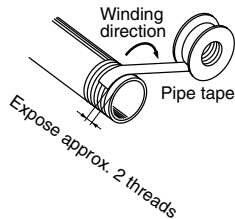

3. Tighten threads with the proper tightening torque.

When screwing fittings into valves, tighten with the torques given below.

Tightening Torque when Piping

Connection threads	Proper tightening torque (N·m)
Rc 1/4	12 to 14
Rc 3/8	22 to 24
Rc 1/2	28 to 30
Rc 3/4	28 to 30
Rc 1	36 to 38

4. Piping to products

When piping to products, avoid making an error of supply port, etc., by referring to the instruction manuals.

5. F.R.L. module combination

When connecting to a modular F.R.L. combinations (AC20 to 60), select one of the spacers, which are included. (Refer to page 14-2-10 for details.) However, modular combinations with AC40-06 are not possible.

Furthermore, connect soft start-up valves to the outlet side of the F.R.L. combination.

6. Inlet side piping conditions

The nominal size of the piping material's or equipment's bore should be equal to or larger than the soft start-up valve's port size. The composite effective area of the inlet side's (P port side's) piping or equipment should be equal to or larger than the values below.

Model	Composite effective area (mm ²)
AV2000	5
AV3000	22
AV4000	35
AV5000	50

When the piping is restricted or the supply pressure is insufficient, the main valve will not switch and air leakage may occur from the R port.

Light/Surge Voltage Suppressor

⚠ Caution

Voltage	AC and 100 VDC	24 VDC or less
Electrical circuit		

Electrical Connection

⚠ Caution

The internal connection of the DIN terminal is as shown below, connect to the power supply side as shown.

DIN terminal

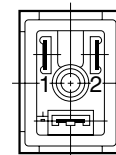

Terminal	1	2
DIN terminal	+	-

Lubrication

⚠ Caution

- The valve has been lubricated for life at the factory, and does not require any further lubrication.
- Use turbine oil Class 1, ISO VG32 (with no additives), if lubricated. Besides, if the lubrication is suspended halfway, the original lubricant will be lost and may result in a malfunction. Be sure to keep lubricating continuously. Refer to the brand name table given below for lubricants by each company, conforming to turbine oil Class 1 (with no additives), ISO VG32.

Turbine Oil Class 1 (With no additives), ISO VG32

Viscosity classification cSt (40°C)	ISO viscosity grade	32	Viscosity classification cSt (40°C)	ISO viscosity grade	32
		Idemitsu Kosan Co.,Ltd. Turbine oil P-32			Kygnus Oil Co. Turbine oil 32
		Nippon Mitsubishi Oil Corp. Turbine oil 32, Mitsubishi Turbine 32			Kyushu Oil Co. Stork turbine 32
		Cosmo Oil Co.,Ltd. Cosmo turbine 32			Showa Shell Sekiyu K.K. Turbine 32
		Japan Energy Corp. Kyodo turbine 32			Tonengeneral Sekiyu K.K. General R turbine 32
					Fuji Kosan Co.,Ltd. Fucoal turbine 32

Please contact SMC regarding turbine oil Class 2 (with additives), ISO VG32.

F.R.L.

AV

AU

AF

AR

IR

VEX

AMR

ITV

IC

VBA

VE□

VY1

G

PPA

AL

⚠ Precautions

Be sure to read before handling. Refer to pages 14-21-3 to 14-21-4 for Safety Instructions and Common Precautions.

Air Supply

⚠ Warning

1. Use clean air.

Do not use compressed air which contains chemicals, synthetic oils containing organic solvents, salts or corrosive gases, etc., as this can cause damage or malfunction.

⚠ Caution

1. Install air filters.

Install air filters close to valves at their upstream side. A filtration degree of 5 µm or less should be selected.

2. Implement countermeasures by installing after-cooler or air dryer, or water separator, etc.

The air including excess drain may result in a malfunction of valves and other pneumatic equipment. Implement countermeasures by installing after-cooler or air dryer, or water separator, etc.

Operating Environment

⚠ Warning

1. Do not use valves in such environments where corrosive gases, chemicals, or brine or water or steam is airborne, or where valves can be directly exposed to any of those.

2. Do not use in an explosive environment.

3. Do not use in locations influenced by vibrations or impacts.

4. A protective cover, etc., should be used to shield valves from direct sunlight.

5. Shield valves from radiated heat generated by nearby heat sources.

6. Take suitable protective measures in locations where there are contacts with water droplets, oil, or welding spatter, etc.

7. In a dusty environment or when valve switching noise is intrusive, install a silencer in the R port to prevent dust from entering, and to reduce noise.

Maintenance

⚠ Warning

1. Perform maintenance and inspection as shown in the instruction manual.

If handled improperly, damage may occur in machine or equipment or an operational error may result in.

2. Equipment removal and supply/exhaust of compressed air

When equipment is removed, first confirm that measures are implemented to prevent dropping of workpiece and runaway of equipment, etc. Then cut the supply pressure and power, and exhaust all compressed air from the system using its residual pressure release function.

3. Low frequency operation

Valves should be switched at least once every 30 days to prevent malfunction. (Use caution regarding the air supply.)

4. Manual override operation

When the manual override is operated, connected equipment will be actuated.

Confirm the safety before operating.

⚠ Caution

1. Drain removal

Remove drain from air filters periodically.

How to Find the Flow Rate

(At air temperature of 20°C)

Choke flow: $(P_2 + 0.1)/(P_1 + 0.1) \leq 0.5$

$$Q = 120 \times S \times (P_1 + 0.1) \times \sqrt{\frac{293}{273 + t}}$$

Subsonic flow: when $(P_2 + 0.1)/(P_1 + 0.1) > 0.5$

$$Q = 240 \times S \times \sqrt{(P_1 - P_2)(P_2 + 0.1)} \times \sqrt{\frac{293}{273 + t}}$$

Q: Air flow rate [ℓ/min (ANR)]

S: Effective area (mm²)

P1: Upstream pressure [MPa]

P2: Downstream pressure [MPa]

t: Air temperature [°C]

Note 1) Formulas above are applied to pneumatics only.

Soft Start-up Valve

AV2000/3000/4000/5000

How to Order

F.R.L.

AV

AU

AF

AR

IR

VEX

AMR

ITV

IC

VBA

VE

VY1

G

PPA

AL

Soft start-up valve

Body size

20	1/4
30	3/8
40	1/2
50	3/4, 1

Thread type

Nil	Rc
F	G
N	NPT

Port size

02	1/4 (AV2000 only)
03	3/8 (AV3000 only)
04	1/2 (AV4000 only)
06	3/4 (AV5000 only)
10	1 (AV5000 only)

Option

Nil	None
G	With pressure gauge

Manual override

Nil	Non-locking push type (Flush)
B	Locking type (Tool required)
C	Locking type (Lever)

Light/Surge voltage suppressor

Nil	None
S	With surge voltage suppressor (Grommet type only)
Z	With light/surge voltage suppressor (Not possible with grommet type)

Coil rated voltage

1	100 VAC (50/60 Hz)
2	200 VAC (50/60 Hz)
3	110 to 120 VAC (50/60 Hz)
4	220 VAC (50/60 Hz)
5	24 VDC
6	12 VDC
9	Other

Electrical entry

G	Grommet
D	Type D DIN terminal
Y	Type Y DIN terminal

How to Order Pilot Valve Assembly

SF4 — 1 G — 80

Rated coil voltage

1	100 VAC (50/60 Hz)
2	200 VAC (50/60 Hz)
3	110 to 120 VAC (50/60 Hz)
4	220 VAC (50/60 Hz)
5	24 VDC
6	12 VDC
9	Other

Soft start-up valve

Manual override

Nil	Non-locking push type (Flush type)
B	Locking type (Tool required)
C	Locking type (Lever type)

Light/Surge voltage suppressor

Nil	None
S	With surge voltage suppressor (Grommet type only)
Z	With light/surge voltage suppressor (Not possible with grommet type)

Electrical entry

G	Grommet
D	Type D DIN terminal
Y	Type Y DIN terminal

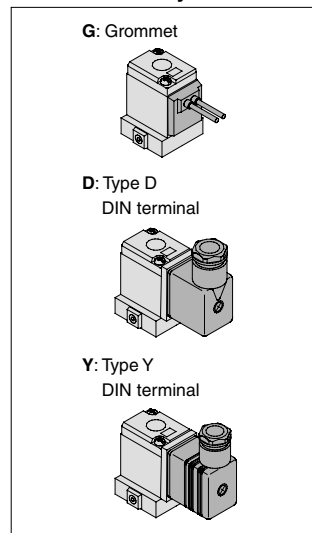

Note) The grommet type can have a surge voltage suppressor (direct coupling type lead wire), but without indicator light.



TÜV approved product
(Conforms to standards necessary to satisfy EC directives.)

Series AV has received approval from TÜV Rheinland, an EC Notified Body (EC authorization number 0197), for conformity to DIN VDE0580: 1994 Standards.

Please consult with SMC for details when ordering TÜV approved products because of restrictions regarding product model, voltage specification, and electrical entry, etc.

Series AV2000/3000/4000/5000



Type D DIN terminal



Type Y DIN terminal

JIS Symbol

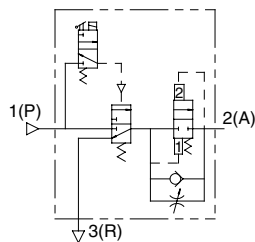

Accessory/Pressure Gauge

Description	Pressure gauge
Part no.	G36-10-01
Pressure range	1 MPa

Specifications

Model		AV2000	AV3000	AV4000	AV5000		
Port size		1/4	3/8	1/2	3/4	1	
Proof pressure		1.5 MPa					
Operating pressure range		0.2 to 1 MPa					
Pressure gauge port size		1/8					
Ambient and fluid temperature		0 to 60°C ⁽¹⁾					
Effective area (mm ²)	1(P) → 2(A)	20	37	61	113	122	
	2(A) → 3(R)	24	49	76	132	141	
Weight (kg)		0.27	0.48	0.74	1.60	1.54	
Electrical specifications	Rated coil voltage	100, 200, 110 to 120, 220 VAC (50/60 Hz), 12, 24 VDC					
	Allowable voltage fluctuation	-15 to +10% of rated voltage					
	Coil insulation type	Equivalent to B type (130°C)					
	Apparent power (Current consumption) AC	Inrush	5.6 VA (50 Hz), 5.0 VA (60 Hz)				
		Energized	3.4 VA (2.1 W)/50 Hz, 2.3 VA (1.5 W)/60 Hz				
	Current consumption DC	1.8 W					
Electrical entry	Grommet, Type D DIN terminal, Type Y DIN terminal						
Option specifications	Indicator light/Surge voltage suppressor ⁽²⁾						
Pilot valve manual override	Non-locking push type (Flush), Locking type (Tool required), Locking type (Lever)						

Note 1) Use dry air when operating at a low temperature.

Note 2) The grommet type is equipped with a surge voltage suppressor (direct coupling type lead wire), but not an indicator light.

Piston B Switching Pressure (Open → Closed)

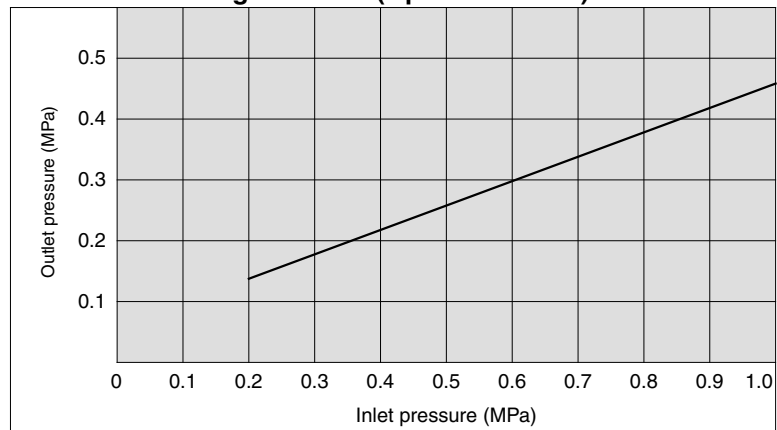

Needle Valve Flow Characteristics

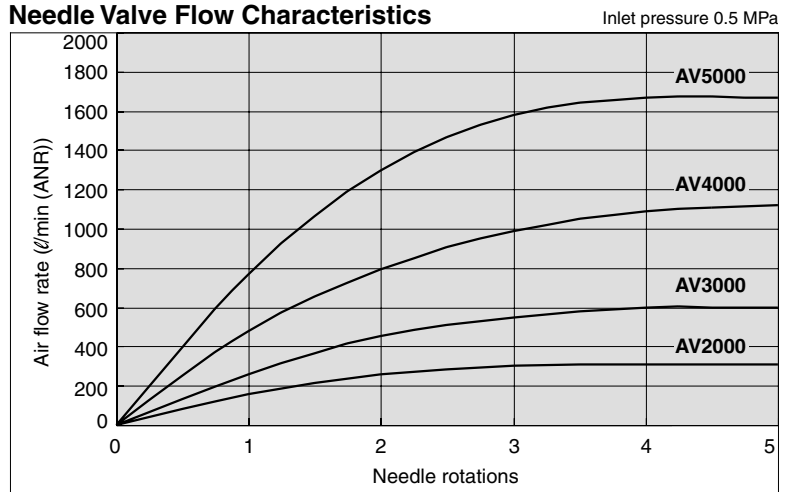

Soft Start-up Valve Series AV2000/3000/4000/5000

Working Principle

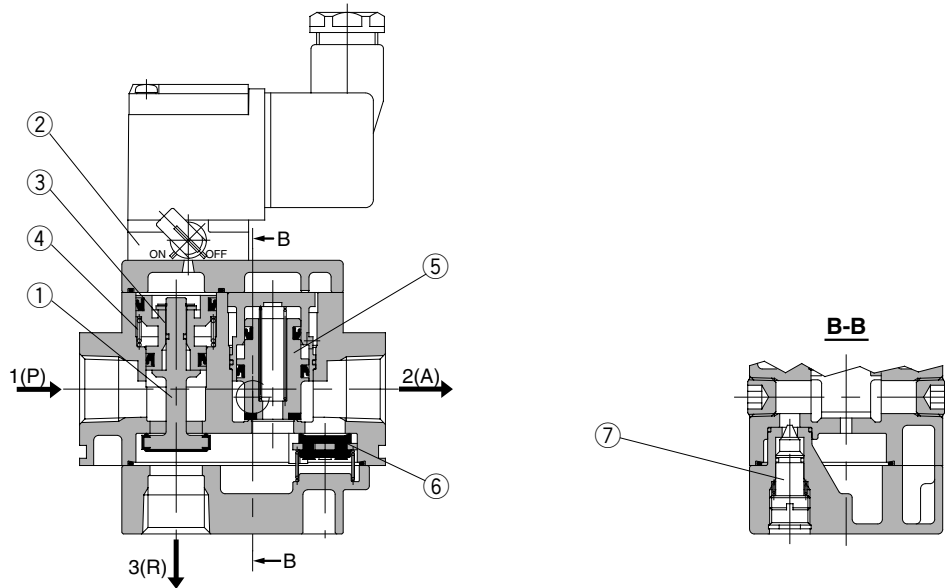

- F.R.L.
- AV**
- AU
- AF
- AR
- IR
- VEX
- AMR
- ITV
- IC
- VBA
- VE□
- VY1
- G
- PPA
- AL

Working condition	Pilot valve	Pressure conditions	Working description	Pressure time chart (Meter-out control) example	Cylinder drive circuit (Meter-out control) example	
Low speed supply	ON	$1/2 PP > PA$	When pilot valve ② is turned ON by energization or manual override, the pilot air pushes piston A ③ and main valve ① downward and opens main valve ① while R port closes simultaneously. The air from P port moves to needle valve ⑦, where its flow is adjusted, and flows to A port. The meter-in control of needle valve ⑦ slowly moves the cylinder from (A) to (B).	<p>Initial Operation Return Stroke</p>		
High speed supply		$1/2 PP \leq PA$	When $1/2 PP \leq PA$ after the cylinder reaches B, piston B ⑤ fully opens and PA increases rapidly as shown from C to D and becomes the same pressure as PP.			
Normal operation		$1/2 PP \equiv PA$	Since piston B ⑤ holds the fully open condition, during normal operation the cylinder's speed will be controlled by the usual meter-out control.			
Quick exhaust	OFF	—	When pilot valve ② is turned OFF, spring ④ pushes piston A ③ and ① upward and opens R port while shutting off the air supply from P port. The pressure difference generated at this time lets the check valve open ⑥ and the residual pressure on the A port side is quickly exhausted from R port.			

Series AV2000/3000/4000/5000

Construction

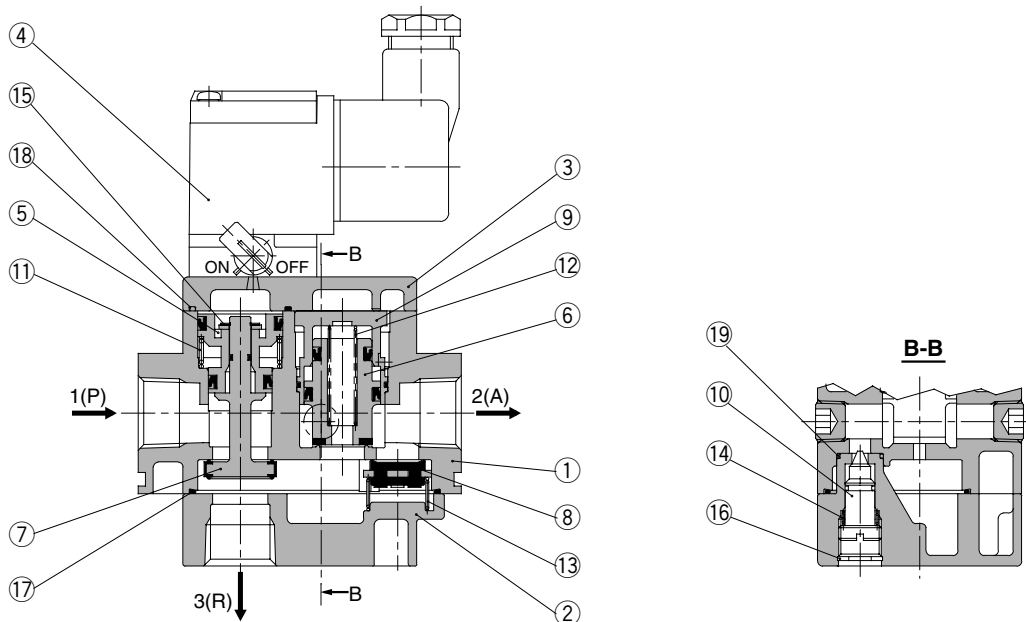

Component Parts

No.	Description	Material
①	Body	ADC
②	Cap	ADC
③	Cover	ADC

Replacement Parts

No.	Description	Material	Part no.			
			AV2000	AV3000	AV4000	AV5000
④	Pilot valve assembly	—	SF4-□-80*1			
⑤	Piston A assembly	POM, NBR	P424204A	P424304A	P424404A	P424504A
⑥	Piston B assembly	Brass, NBR (HNBR)	P424205A	P424305A	P424405A	P424505A
⑦	Main valve assembly	Brass, NBR (HNBR)	P424206A	P424306A	P424406A	P424506A
⑧	Check valve	Brass, NBR (HNBR)	P424207	P424307	P424407	P424507
⑨	Piston guide assembly	POM, NBR	P424208A	P424308A	P424408A	P424508A
⑩	Needle assembly	Brass, NBR	P424209A	P424309A	P424409A	P424509A
⑪	Valve spring	Steel wire	P424211	P424311	P424411	P424511
⑫	Piston spring	Stainless steel	P424212	P424312	P424412	P424512
⑬	Check spring	Stainless steel	P424213	P424313	P424413	P424513
⑭	Needle spring	Steel wire	P424214	P424314	P424414	—
⑮	Type C snap ring for shaft	Tool steel	G-5	STW-5	STW-8	STW-10
⑯	Type C snap ring for hole	Tool steel	0-9	0-10	RTW-12	RTW-15
⑰	Seal	NBR	P424210	P424310	P424410	P424510
⑱	Seal	NBR	P424218	P424315	P424415	P424514
⑲	O-ring	NBR	10 x 8 x 1	11 x 9 x 1	12.5 x 9.5 x 1.5	16.5 x 12.5 x 2

*1 For "How to Order" pilot valve assembly, refer to page 14-3-5.

Soft Start-up Valve Series AV2000/3000/4000/5000

Dimensions

Grommet: AV□00-□-□G, GS

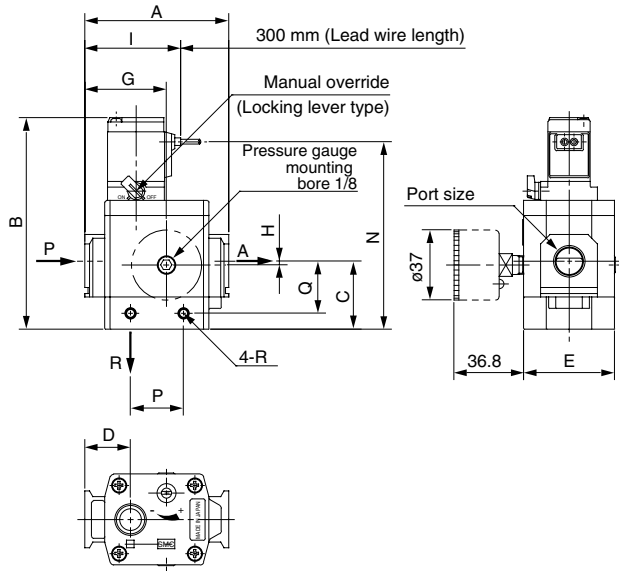

DIN terminal: AV□00-□-□D, DZ

DIN terminal for European use: AV□00-□-□Y, YZ

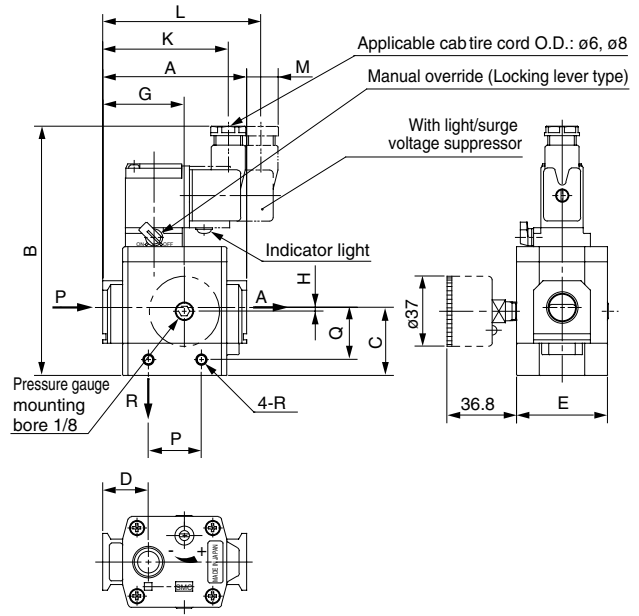

F.R.L.

AV

AU

AF

AR

IR

VEX

AMR

ITV

IC

VBA

VE□

VY1

G

PPA

AL

Model	Port size	A	B	C	D	E	G	H	I	K	L	M	N	P	Q	R
AV2000-□02-□G□	1/4	66	105	31	22	40	38	0	47.5	—	—	—	93	29	23.5	M4 x 0.7 Depth 4.5
AV2000-□02-□GS□										—	—	—				
AV2000-□02-□D□	1/4	66	125	31	22	40	38	0	—	65.5	—	6	—	29	23.5	M4 x 0.7 Depth 4.5
AV2000-□02-□DZ□										—	82.5	23				
AV2000-□02-□Y□	1/4	66	125	31	22	40	38	0	—	67.5	—	10.5	—	29	23.5	M4 x 0.7 Depth 4.5
AV2000-□02-□YZ□										—	84.5	27.5				
AV3000-□03-□G□	3/8	76	112	36	24	48	43	2	50.5	—	—	—	100	28	27.5	M5 x 0.8 Depth 5
AV3000-□03-□GS□										—	—	—				
AV3000-□03-□D□	3/8	76	132	36	24	48	43	2	—	68.5	—	—	—	28	27.5	M5 x 0.8 Depth 5
AV3000-□03-□DZ□										—	85.5	16				
AV3000-□03-□Y□	3/8	76	132	36	24	48	43	2	—	70.5	—	3.5	—	28	27.5	M5 x 0.8 Depth 5
AV3000-□03-□YZ□										—	87.5	20.5				
AV4000-□04-□G□	1/2	98	127	47	32	52	57	3	62.5	—	—	—	115	42	37	M6 x 1 Depth 6
AV4000-□04-□GS□										—	—	—				
AV4000-□04-□D□	1/2	98	147	47	32	52	57	3	—	80.5	—	—	—	42	37	M6 x 1 Depth 6
AV4000-□04-□DZ□										—	97.5	6				
AV4000-□04-□Y□	1/2	98	147	47	32	52	57	3	—	82.5	—	—	—	42	37	M6 x 1 Depth 6
AV4000-□04-□YZ□										—	99.5	10.5				
AV5000-□06-□G□	3/4, 1	128	155	59	39	74	77	0	74	—	—	—	143	50	46	M6 x 1 Depth 7.5
AV5000-□06-□GS□										—	—	—				
AV5000-□06-□D□	3/4, 1	128	175	59	39	74	77	0	—	90	—	—	—	50	46	M6 x 1 Depth 7.5
AV5000-□06-□DZ□										—	107	—				
AV5000-□06-□Y□	3/4, 1	128	175	59	39	74	77	0	—	94	—	—	—	50	46	M6 x 1 Depth 7.5
AV5000-□06-□YZ□										—	111	—				

Series AV2000/3000/4000/5000

Connecting Spacer for Modular Style F.R.L. Unit

Select one of the spacers below when connecting to an F.R.L. combination unit (AC20 to AC60).
(Spacers must be ordered separately.)

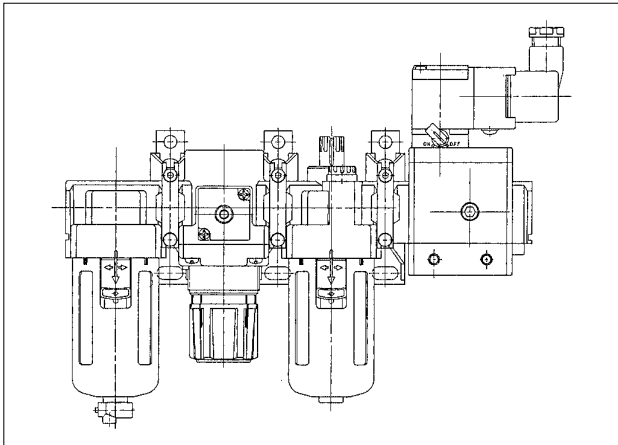

Spacer



Y200

Y400

Model	Applicable model
Y200	AV2000
Y300	AV3000
Y400	AV4000
Y600	AV5000

Spacer with bracket

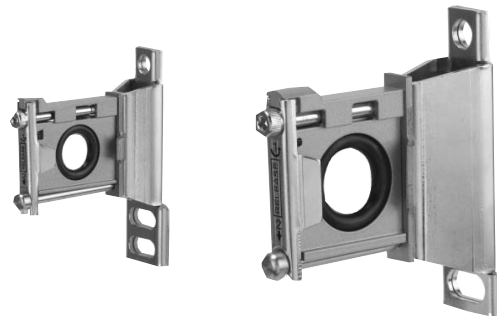

Y200T

Y400T

Model	Applicable model
Y200T	AV2000
Y300T	AV3000
Y400T	AV4000
Y600T	AV5000



Safety Instructions

These safety instructions are intended to prevent a hazardous situation and/or equipment damage. These instructions indicate the level of potential hazard by labels of "**Caution**", "**Warning**" or "**Danger**". To ensure safety, be sure to observe ISO 4414 ^{Note 1)}, JIS B 8370 ^{Note 2)} and other safety practices.

⚠ Caution : Operator error could result in injury or equipment damage.

⚠ Warning : Operator error could result in serious injury or loss of life.

⚠ Danger : In extreme conditions, there is a possible result of serious injury or loss of life.

Note 1) ISO 4414: Pneumatic fluid power--General rules relating to systems.

Note 2) JIS B 8370: General Rules for Pneumatic Equipment

⚠ Warning

1. The compatibility of pneumatic equipment is the responsibility of the person who designs the pneumatic system or decides its specifications.

Since the products specified here are used in various operating conditions, their compatibility for the specific pneumatic system must be based on specifications or after analysis and/or tests to meet your specific requirements. The expected performance and safety assurance will be the responsibility of the person who has determined the compatibility of the system. This person should continuously review the suitability of all items specified, referring to the latest catalog information with a view to giving due consideration to any possibility of equipment failure when configuring a system.

2. Only trained personnel should operate pneumatically operated machinery and equipment.

Compressed air can be dangerous if an operator is unfamiliar with it. Assembly, handling or repair of pneumatic systems should be performed by trained and experienced operators.

3. Do not service machinery/equipment or attempt to remove components until safety is confirmed.

1. Inspection and maintenance of machinery/equipment should only be performed once measures to prevent falling or runaway of the driver objects have been confirmed.
2. When equipment is to be removed, confirm the safety process as mentioned above. Cut the supply pressure for this equipment and exhaust all residual compressed air in the system.
3. Before machinery/equipment is restarted, take measures to prevent shooting-out of cylinder piston rod, etc.

4. Contact SMC if the product is to be used in any of the following conditions:

1. Conditions and environments beyond the given specifications, or if product is used outdoors.
2. Installation on equipment in conjunction with atomic energy, railway, air navigation, vehicles, medical equipment, food and beverages, recreation equipment, emergency stop circuits, clutch and brake circuits in press applications, or safety equipment.
3. An application which has the possibility of having negative effects on people, property, or animals, requiring special safety analysis.



Common Precautions

Be sure to read before handling.

For detailed precautions on every series, refer to main text.

Selection

Warning

1. Confirm the specifications.

Products represented in this catalog are designed for use in compressed air applications only (including vacuum), unless otherwise indicated.

Do not use the product outside their design parameters.

Please contact SMC when using the products in applications other than compressed air (including vacuum).

Mounting

Warning

1. Instruction manual

Install the products and operate them only after reading the instruction manual carefully and understanding its contents. Also keep the manual where it can be referred to as necessary.

2. Securing the space for maintenance

When installing the products, please allow access for maintenance.

3. Tightening torque

When installing the products, please follow the listed torque specifications.

Piping

Caution

1. Before piping

Make sure that all debris, cutting oil, dust, etc. are removed from the piping.

2. Wrapping of pipe tape

When screwing piping or fittings into ports, ensure that chips from the pipe threads or sealing material do not get inside the piping. Also, when the pipe tape is used, leave 1.5 to 2 thread ridges exposed at the end of the threads.

Air Supply

Warning

1. Operating fluid

Please consult with SMC when using the product in applications other than compressed air (including vacuum).

Regarding products for general fluid, please ask SMC about applicable fluids.

2. Install an air dryer, aftercooler, etc.

Excessive condensate in a compressed air system may cause valves and other pneumatic equipment to malfunction.

Installation of an air dryer, after cooler etc. is recommended.

3. Drain flushing

If condensate in the drain bowl is not emptied on a regular basis, the bowl will overflow and allow the condensate to enter the compressed air lines.

If the drain bowl is difficult to check and remove, it is recommended that a drain bowl with the auto-drain option be installed.

For compressed air quality, refer to "Air Preparation Equipment" catalog.

4. Use clean air

If the compressed air supply is contaminated with chemicals, synthetic materials, corrosive gas, etc., it may lead to breakdown or malfunction.

Operating Environment

Warning

1. Do not use in environments where the product is directly exposed to corrosive gases, chemicals, salt water, water or steam.

2. Do not expose the product to direct sunlight for an extended period of time.

3. Do not use in a place subject to heavy vibrations and/or shocks.

4. Do not mount the product in locations where it is exposed to radiant heat.

Maintenance

Warning

1. Maintenance procedures are outlined in the operation manual.

Not following proper procedures could cause the product to malfunction and could lead to damage to the equipment or machine.

2. Maintenance work

If handled improperly, compressed air can be dangerous.

Assembly, handling and repair of pneumatic systems should be performed by qualified personnel only.

3. Drain flushing

Remove drainage from air filters regularly. (Refer to the specifications.)

4. Shut-down before maintenance

Before attempting any kind of maintenance make sure the supply pressure is shut off and all residual air pressure is released from the system to be worked on.

5. Start-up after maintenance and inspection

Apply operating pressure and power to the equipment and check for proper operation and possible air leaks. If operation is abnormal, please verify product set-up parameters.

6. Do not make any modifications to be product.

Do not take the product apart.

Quality Assurance Information (ISO 9001, ISO 14001)

Reliable quality of products in the global market

To enable our customers throughout the world to use our products with even greater confidence, SMC has obtained certification for international standards "ISO 9001" and "ISO 14001", and created a complete structure for quality assurance and environmental controls. SMC products pursue to meet its customers' expectations while also considering company's contribution in society.

SMC's quality control system

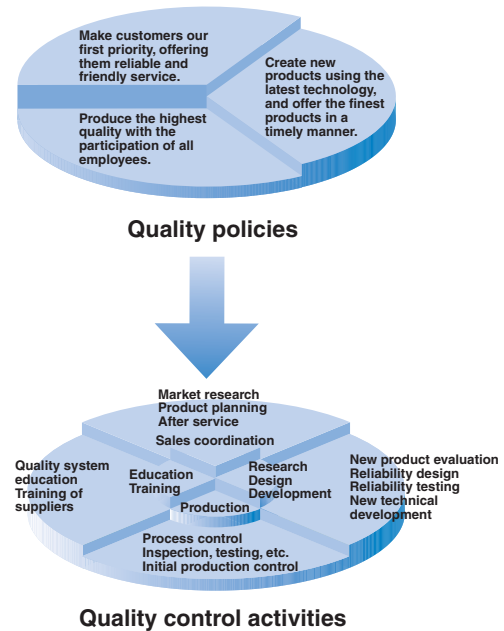

Quality management system ISO 9001

This is an international standard for quality control and quality assurance. SMC has obtained a large number of certifications in Japan and overseas, providing assurance to our customers throughout the world.



Environmental management system ISO 14001

This is an international standard related to environmental management systems and environmental inspections. While promoting environmentally friendly automation technology, SMC is also making diligent efforts to preserve the environment.



SMC Product Conforming to Inter

SMC products complying with EN/ISO, CSA/UL standards are supporting



The CE mark indicates that machines and components meet essential requirements of all the EC Directives applied.

It has been obligatory to apply CE marks indicating conformity with EC Directives when machines and components are exported to the member Nations of the EU.

Once "A manufacturer himself" declares a product to be safe by means of CE marking (declaration of conformity by manufacturer), free distribution inside the member Nations of the EU is permissible.

■ CE Mark

SMC provides CE marking to products to which EMC and Low Voltage Directives have been applied, in accordance with CETOP (European hydraulics and pneumatics committee) guide lines.

■ As of February 1998, the following 18 countries will be obliged to conform to CE mark legislation

Iceland, Ireland, United Kingdom, Italy, Austria, Netherlands, Greece, Liechtenstein, Sweden, Spain, Denmark, Germany, Norway, Finland, France, Belgium, Portugal, Luxembourg

■ EC Directives and Pneumatic Components

• Machinery Directive

The Machinery Directive contains essential health and safety requirements for machinery, as applied to industrial machines e.g. machine tools, injection molding machines and automatic machines. Pneumatic equipment is not specified in Machinery Directive. However, the use of SMC products that are certified as conforming to EN Standards, allows customers to simplify preparation work of the Technical Construction File required for a Declaration of Conformity.

• Electromagnetic Compatibility (EMC) Directive

The EMC Directive specifies electromagnetic compatibility. Equipment which may generate electromagnetic interference or whose function may be compromised by electromagnetic interference is required to be immune to electromagnetic affects (EMS/immunity) without emitting excessive electromagnetic affects (EMI/emission).

• Low Voltage Directive

This directive is applied to products, which operate above 50 VAC to 1000 VAC and 75 VDC to 1500 VDC operating voltage, and require electrical safety measures to be introduced.

• Simple Pressure Vessels Directive

This directive is applied to welded vessels whose maximum operating pressure (PS) and volume of vessel (V) exceed 50 bar/L. Such vessels require EC type examination and then CE marking.

national Standards

you to comply with EC directives and CSA/UL standards.



■ CSA Standards & UL Standards

UL and CSA standards have been applied in North America (U.S.A. and Canada) symbolizing safety of electric products, and are defined to mainly prevent danger from electric shock or fire, resulting from trouble with electric products. Both UL and CSA standards are acknowledged in North America as the first class certifying body. They have a long experience and ability for issuing product safety certificate. Products approved by CSA or UL standards are accepted in most states and governments beyond question.

Since CSA is a test certifying body as the National Recognized Testing Laboratory (NRTL) within the jurisdiction of Occupational Safety and Health Administration (OSHA), SMC was tested for compliance with CSA Standards and UL Standards at the same time and was approved for compliance with the two Standards. The above CSA NRTL/C logo is described on a product label in order to indicate that the product is approved by CSA and UL Standards.

■ TSSA (MCCR) Registration Products

TSSA is the regulation in Ontario State, Canada. The products that the operating pressure is more than 5 psi (0.03 MPa) and the piping size is bigger than 1 inch. fall into the scope of TSSA regulation.

Products conforming to CE Standard



With CE symbol for simple visual recognition

In this catalog each accredited product series is indicated with a CE mark symbol. However, in some cases, every available models may not meet CE compliance. Please visit our web site for the latest selection of available models with CE mark.

<http://www.smcworld.com>

SOFT START-UP VALVE SERIES (N)AV 2000, 3000, 4000 1/4, 3/8, 1/2"

- ✓ Combined Soft Start and Dump Valve
- ✓ Compatible with Modular Series FRL
- ✓ Large Cv Factor
- ✓ Low Power
- ✓ Air Supply and Exhaust can be operated manually

SYMBOLS

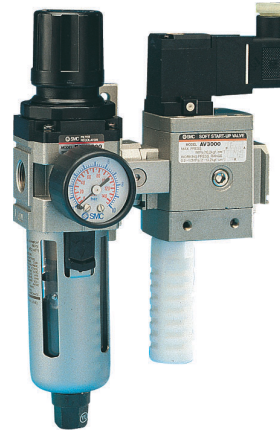
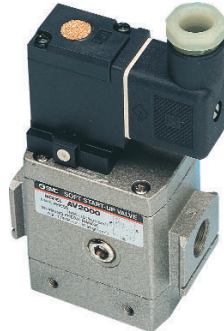
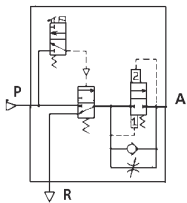

The NAV valve pictured together with an NAW series Filter/Regulator and an NAN series Silencer. (To order these items, see Air Preparation section {NAW} and Valves section {NAN})

TECHNICAL SPECIFICATIONS

Model	NAV2000	NAV3000	NAV4000		
Port Size	1/4	3/8	1/2		
Proof Pressure	1.5MPa / 220PSI				
Operating Pressure Range	1MPa / 145PSI				
Pressure Gauge Port Size	1/4				
Ambient and Fluid Temperature	0 ~ 60°C* / 32~140°F				
CV Factor	P→A	1.19	2.20	3.60	
	A→R	1.39	2.89	4.49	
Weight (kg)	0.27	0.48	0.74		
Electrical Spec	Coil Rated Voltage	110, 240V AC (50/60Hz); 12, 24V DC			
	Allowable Voltage Fluctuation	-15% to +10% of rated voltage			
	Coil Insulation Type	Type B equivalent (130°C)			
	Apparent Power AC (Power Consumption)	Inrush	5.6VA (50Hz)		
		Holding	3.4VA (2.1W)/50Hz		
	Power Consumption DC	1.8W			
	Electrical Connector	DIN 43650 (industrial form)			
Semi-Standard Spec	With indicator light and surge voltage suppressor				
Pilot Valve Manual Override	Non-locking push type				

*Use dry air when temperature is low.

HOW TO ORDER

SOFT START-UP VALVE

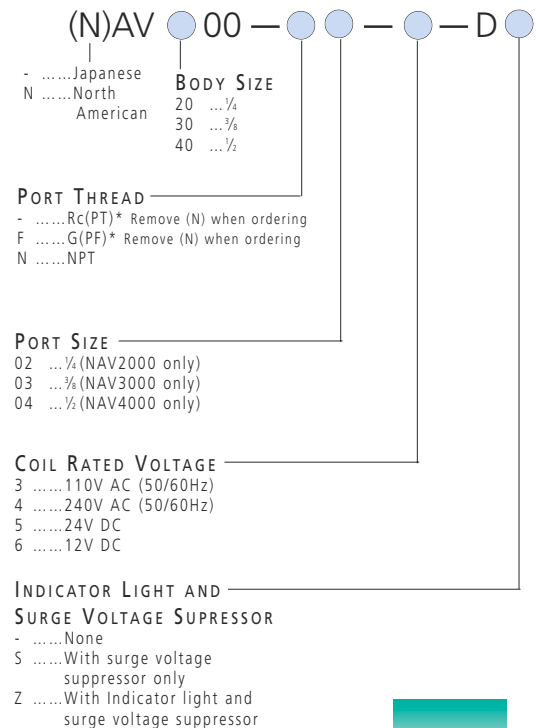

DIMENSIONS
SEE NEXT PAGE

SEE INSIDE FRONT COVER FOR
DETAILS OF YOUR LOCAL SALES OFFICE



FOR FURTHER TECHNICAL
DETAILS ON THIS
PRODUCT REQUEST
CATALOG REFERENCE
ESG & N5-G1

DIMENSIONS
DIN CONNECTOR

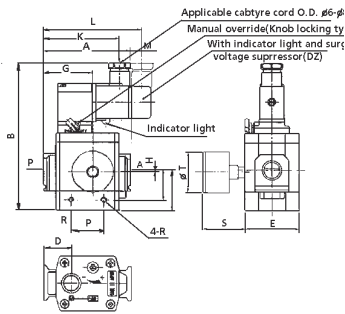

Model	Port size	A	B	C	D	E	Pressure gauge Mounting port	G	H	I	J	K	L	M	N	P	Q	R
							F											
NAV2000-□02-□D	1/4	66	125.5	31	22	40	1/8	38	0	—	—	67.5	—	10.5	—	29	23.5	M4X0.7 depth 4.5
NAV2000-□02-□DZ												—	84.5	27.5				
NAV3000-□03-□D	3/8	76	132.5	36	24	48	1/8	43	2	—	—	70.5	—	3.5	—	28	27.5	M5X0.8 depth 5
NAV3000-□03-□DZ												—	87.5	20.5				
NAV4000-□04-□D	1/2	98	147.5	47	32	52	1/8	57	3	—	—	82.5	—	—	—	42	37	M6X1 depth 6
NAV4000-□04-□DZ												—	99.5	10.5				

DIMENSIONS
EXAMPLE OF NAC3000 + SOFT START-UP VALVE

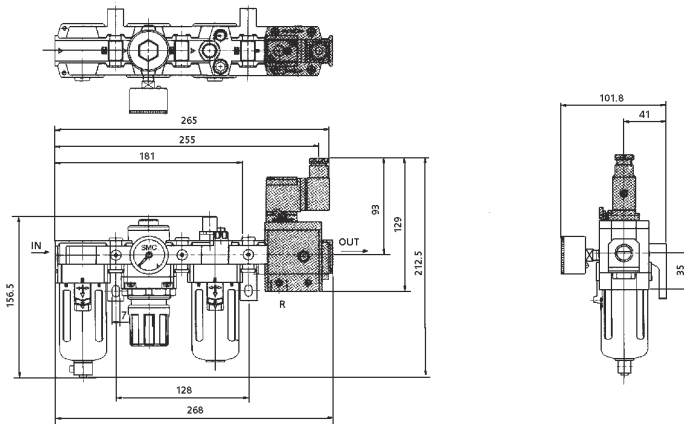

1. This valve cannot prevent cylinders shooting out when a closed-center solenoid valve is used, or equipment driving with a load factor of 50% or more.
2. When a regulator is to be mounted on the secondary side, use a check valve regulator (NAR**60). Standard regulators (NAR2000, 3000, 4000) do not allow large volume back-flow.
3. Mount a lubricator, as necessary, on the primary side (P port side) of the valve. When the lubricator is mounted on the secondary side (A port side), oil back-flows and is exhausted from port R.

Related Products

Conforming to OSHA Standard Pressure Relief 3-Port Valve with Locking Hole VHS 20/30/40/50

Manually operated valve can be used to prevent accidents caused by residual pressure in pneumatic lines.

Can prevent accidents due to inadvertent air supply.

When in the exhaust position, the valve may be padlock secured. Prevents accidental start-ups while personnel are cleaning or servicing equipment.

The supply/exhaust status of the air flow can be verified at a glance in the indicating window.

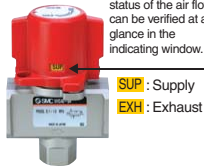

SUP: Supply
EXH: Exhaust

OSHA standard (Occupational Safety and Health Administration Department of Labor)

For safety control, OSHA rule requires energy sources for certain equipment be turned off or disconnected and that the device either be locked or labelled with a warning tag.

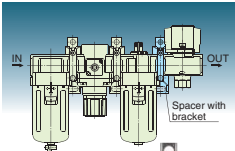

Combination with a modular style FRL

Combination with a modular style FRL is possible.

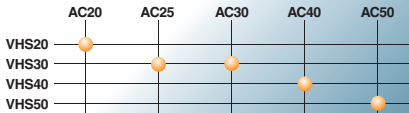

An interface part is required if a spacer or spacer with bracket shown in the table below is attached to a modular FRL.

Pressure relief 3-port valve	Interface P/N	Spacer with bracket P/N	Applicable air preparation equipment
VHS20	Y200	Y200T	AC20
VHS30	Y300	Y300T	AC25, AC30
VHS40	Y400	Y400T	AC40
VHS40-06	Y500	Y500T	AC40-06
VHS50	Y600	Y600T	AC50, AC60 (Note)

Note) Although connection to AC60 is possible, the flow rate may decrease due to the mounting position.

Locations in North America

- Atlanta
- Indianapolis [M]
- Phoenix
- Austin
- Los Angeles [M]
- Portland
- Boston
- Milwaukee
- Richmond
- Charlotte
- Minneapolis
- Rochester
- Chicago
- Montreal
- San Francisco
- Cincinnati
- Nashville
- St. Louis
- Cleveland
- New Jersey
- Tampa
- Dallas
- Toronto [M]
- Detroit
- Vancouver
- Windsor

[M] = Manufacturing

Locations Worldwide!

The Americas

- Argentina
- Bolivia
- Brazil
- Canada
- Chile
- Mexico
- U.S.A.
- Venezuela

Europe

- Austria
- Bulgaria
- Croatia
- Czech
- Denmark
- Estonia
- Finland
- France
- Germany
- Hungary
- Ireland
- Italy
- Latvia
- Lithuania
- Netherlands
- Norway
- Poland
- Romania
- Russia
- Slovakia
- Slovenia
- Sweden
- Spain/Portugal
- Switzerland
- U.K.

Asia

- China
- Hong Kong
- India
- Japan
- Malaysia
- Philippines
- South Korea
- Singapore
- Taiwan
- Thailand

Oceania

- Australia
- New Zealand



SMC Corporation of America
3011 N. Franklin Road
Indianapolis IN 46226

SMC Pneumatics (Canada) Ltd.
6768 Financial Drive Mississauga
Ontario L5N 7J6 Canada

© 2006 SMC Corporation of America. All Rights Reserved.
All reasonable efforts to ensure the accuracy of the information detailed in this catalog were made at the time of publishing. However, SMC can in no way warrant the information herein contained as specifications are subject to change without notice.
Nov06-JBS25M-LA



Soft Start Up Valve With Lock Out



Series AVL2000/3000/4000/5000

Soft start up valve with lock out

- Large effective area
- Low power consumption
- Manual/Manual solenoid lock out
- Modular design

AVL2000/3000/4000/5000

O.S.H.A compliant-lockable soft start valve. Gradual increase of supply pressure and rapid exhaust of system air when the supply is shut off.

How to Order

AVL 20 00 - F 02 G 5 DZM - R

Soft start valve with lock out

Body size

20	1/4
30	3/8
40	1/2
50	3/4, 1

Port thread

Nil	Rc
N	NPT
F	G

Port size

02	1/4 (AVL2000)
03	3/8 (AVL3000)
04	1/2 (AVL4000)
06	3/4 (AVL5000)
10	1 (AVL5000)

Rated coil voltage

Nil	Manual lockout
1	100VAC (50/60Hz)
2	200VAC (50/60Hz)
3	110 to 120VAC (50/60Hz)
4	220VAC (50/60Hz)
5	24VDC
6	12VDC
9	Others

Option

Nil	No gauge
G	Pressure gauge (Unit: MPa)
P	Pressure gauge (Unit: MPa, psi)

Air direction

Nil	Left to Right
R	Right to Left

Electric entry

Nil	Manual lockout
D	D type DIN connector
DZ	D type DIN connector with indicator light & suppressor
DZM	D type DIN connector with M12 connector, indicator light & surge voltage suppressor



Dimension AVL2000 to AVL5000

(mm)

Model	Port size	A	B	C	D	E	F	G	H
AVL2000-02	1/4	67	-	111	31	55	-	40	64 (Max. 73)
AVL2000-02-DZM	1/4	67	20.5	111	31	55	34	40	64 (Max. 73)
AVL3000-03	3/8	76	-	118	36	57	-	48	64 (Max. 73)
AVL3000-03-DZM	3/8	76	12.5	118	36	57	34	48	64 (Max. 73)
AVL4000-04	1/2	98	-	133	47	61	-	52	64 (Max. 73)
AVL4000-04-DZM	1/2	98	-	133	47	61	34	52	64 (Max. 73)
AVL5000-06 to 10	3/4 & 1	128	-	161	59	77	-	74	64 (Max. 73)
AVL5000-06 to 10-DZM	3/4 & 1	128	-	161	59	77	34	74	64 (Max. 73)

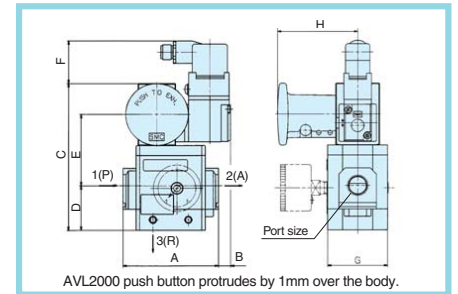

Dimension AC20* to AC60*

(mm)

Model	A1	A2	A3
AC20*	41.5	43	67.5
AC25*	55	57	78
AC30*	55	57	78
AC40*	72.5	75	100.5
AC50*	93	96	131
AC55*	98	96	131
AC60*	98	101	131

Specifications

Model	AV2000	AV3000	AV4000	AV5000
Port size	1/4	3/8	1/2	3/4
Proof pressure	225psi (1.5MPa)			
Operating pressure range	30 to 150psi (0.2 to 1MPa)			
Ambient and fluid temperature	32 to 140°F (0 to 60°C)			
Effective area (mm ²)	1(P) to 2(A)	20	37	61
	2(A) to 3(R)	24	49	76
Weight manual/solenoid (Kg/lb)	0.64 (1.14)	0.74 (1.63)	1.00 (2.21)	1.90 (4.19)
Weight manual (Kg/lb)	0.52 (1.15)	0.62 (1.37)	0.88 (1.94)	1.78 (3.93)
Rated coil voltage	100, 200, 110 to 120, 220VAC (50/60Hz), 12, 24VDC			
Allowable voltage fluctuation	-15% to +10% of rated voltage			
Coil insulation type	Equivalent to B type [266°F (130°C)]			
Current consumption	AC Inrush	5.6V (50Hz), 5.0VA (60Hz)		
	Energized	3.4VA (2.1W) 50Hz, 2.3VA (1.5W) 60Hz		
Current consumption DC	1.8W			
Electric entry	Type D DIN Terminal, M12 connector			
Optional specification	Indicator light/Surge voltage suppressor			

Piston B Switching Pressure (Close to Open)

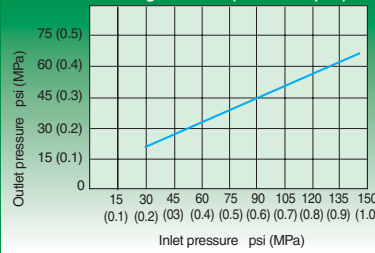

Combination with a modular style FRL is possible.

