

## Description

Single pole thermal-magnetic circuit breakers with tease-free, trip-free, press-to-reset, snap action mechanism (R-type TM CBE to EN 60934; M-type with manual release (-H)). Available with fast acting and standard magnetic tripping characteristics - types 3300 and 3400 - both with threadneck panel mounting. Options include auxiliary contacts, a separate shunt tap terminal (-A3), and pull-to-trip manual release (-H). Approved to CBE standard EN 60934 (IEC 60934).

## Typical applications

Control systems, instrumentation, medical equipment, machine tools, robotics.

## Ordering information

<b>Type No.</b>	
3300	fast acting
3400	standard delay
<b>Mounting</b>	
iG2	moulded threadneck M12x1 (bulk-shipped), not with -H;
...	leave blank for metal threadneck, required for -H
<b>Terminal design</b>	
P10	blade terminals 6.3-0.8 (QC .250)
K20	screw terminals M3.5x5.5 with clamp (not for -Si and -A3)
<b>Shunt terminal (optional)</b>	
A3	same as main terminals, up to $I_N=7$ A max. load 5 A
<b>Manual release (optional)</b>	
H	manual release facility (pull), without reinforced insulation in operating area, for M12x1 metal threadneck only. Metal threadneck version for -H is not approved.
<b>Auxiliary contacts (optional)</b>	
Si	with silver-plated solder terminals (N/O and N/C)
<b>Push button marking (optional)</b>	
1	without
<b>Current ratings</b>	
0.05...16 A	
3400 - iG2 - P10 - ... - ... - Si - ... - 10 A ordering example, without manual release and with moulded threadneck	
3400 - ... - P10 - ... - H - Si - ... - 10 A ordering example, with manual release and metal threadneck	

The exact part number required can be built up from the table of choices shown above. Ordering references for optional features should be omitted if not required.

## Standard current ratings and typical internal resistance values

Current ratings (A)	Internal resistance (Ω)		Current ratings (A)	Internal resistance (Ω)	
	3300	3400		3300	3400
0.05	447	211	3	0.18	0.19
0.1	131	131	4	0.109	0.090
0.2	41	40	5	0.066	0.061
0.3	19.6	19.3	6	0.046	0.041
0.4	10.4	10.4	7	0.032	0.034
0.5	7.2	7.1	8	0.02	≤ 0.02
0.6	4.8	4.3	10	≤ 0.02	≤ 0.02
0.8	2.5	2.5	12	≤ 0.02	≤ 0.02
1	1.93	1.67	13	≤ 0.02	≤ 0.02
1.5	0.81	0.61	14	≤ 0.02	≤ 0.02
2	0.44	0.38	15	≤ 0.02	≤ 0.02
2.5	0.27	0.24	16	≤ 0.02	≤ 0.02



**3300**  
fast acting

**3400**  
standard delay

## Technical data

For further details please see chapter: Technical Information

Voltage rating	AC 240 V, 50/60 Hz; DC 65 V (UL: AC 250 V; DC 80 V)	
Current ratings	0.05...16 A	
Auxiliary circuit	1 A, AC 240 V / DC 65 V	
Typical life with -H:	5,000 operations at 1 x $I_N$ , inductive 5,000 operations at 2 x $I_N$ , resistive	
without -H:	0.05...8 A > 8 A	5,000 operations at 2 x $I_N$ , inductive 1,500 operations at 2 x $I_N$ , inductive
Ambient temperature	-30...+60 °C (-22...+140 °F)	
Insulation co-ordination (IEC 60664 and 60664 A) operating area	rated impulse withstand voltage 2.5 kV	pollution degree 2 reinforced insulation in operating area
Dielectric strength (IEC 60664 and 60664A) operating area	test voltage AC 3,000 V double insulation	
main circuit/aux. circuit	AC 1,500 V	
aux. circuit 4-5/6-7	AC 840 V	
Insulation resistance	> 100 MΩ (DC 500 V)	
Interrupting capacity $I_{cn}$	0.05...0.8 A 1...2 A 2.5...16 A	self-limiting 200 A 400 A
Interrupting capacity (UL 1077)	$I_N$ 0.05...16 A 0.05...16 A	$U_N$ AC 250 V 1,000 A DC 80 V 1,000 A
Degree of protection (IEC 60529/DIN 40050)	operating area IP40 terminal area IP00	
Vibration	5 g (57-500 Hz), ± 0.38 mm (10-57 Hz) to IEC 60068-2-6, test Fc 10 frequency cycles/axis	
Shock	25 g (11 ms) to IEC 60068-2-27, test Ea	
Corrosion	96 hours at 5 % salt mist to IEC 60068-2-11, test Ka	
Humidity	240 hours at 95 % RH, to IEC 60068-2-3, test Ca	
Mass	3300: approx. 55 g 3400: approx. 50 g	

## Approvals

Authority	Voltage ratings	Current ratings
VDE (EN 60934)	AC 240 V; DC 65 V	0.05...16 A
CSA, UL	AC 250 V; DC 80 V	0.05...16 A
UL: only type 3400	DC 65 V	0.05...25 A

2

**Dimensions**

**-iG2-P10**

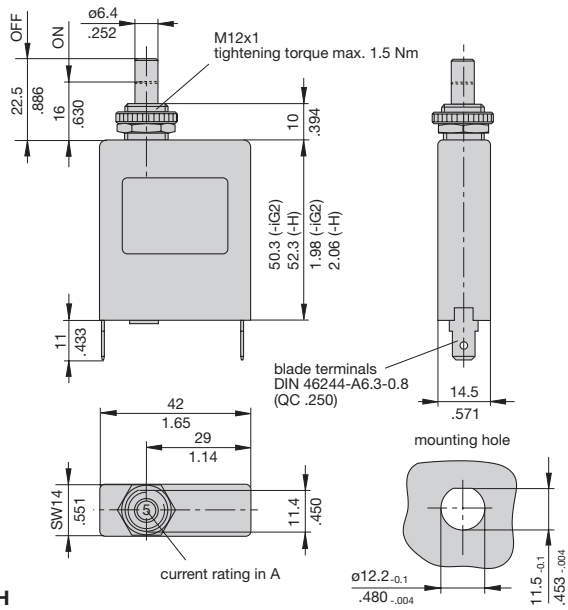

**-H**

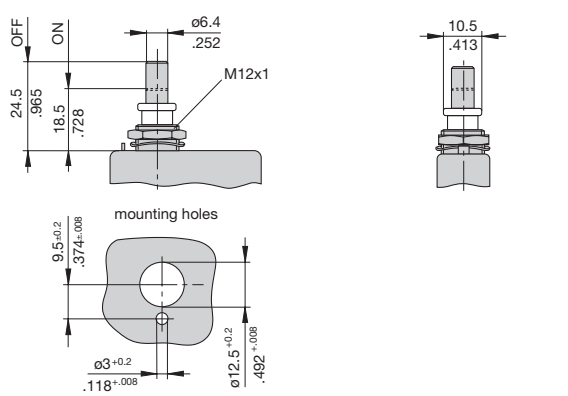

**Internal connection diagrams**

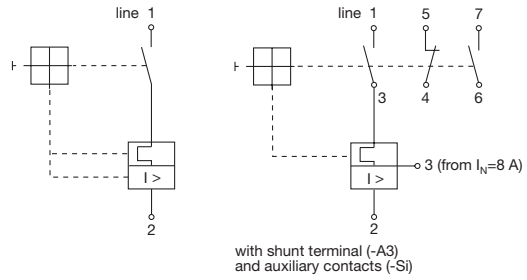

**Terminal design**

**-P10-A3**

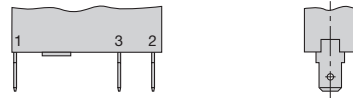

**-P10-Si**

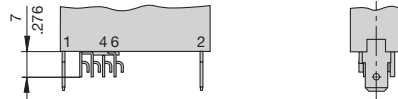

**-K20**

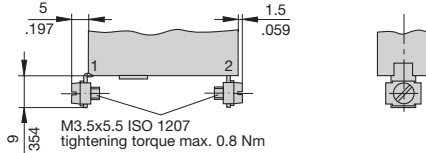

**Installation drawing**

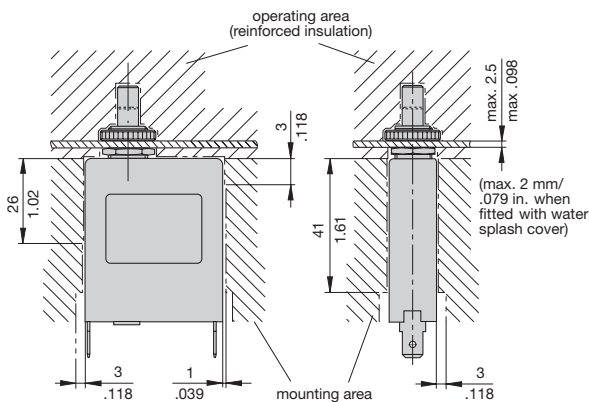

This is a metric design and millimeter dimensions take precedence ( $\frac{mm}{inch}$ )