

0327/0351/0373

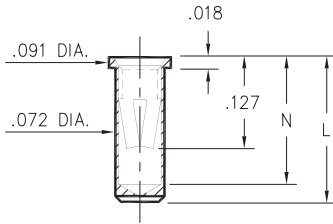

Basic Part Number	Length L	Depth N
0327-0	.206	.180
0351-0	.226	.200
0373-0	.270	.241

03XX-0-15-XX-34-XX-10-0
Solder mount in .075 min. mounting hole
Also available on 12mm wide carrier tape: 1,400 parts per 13" reel.
Order as: 0327-0-57-XX-34-XX-10-0

0328

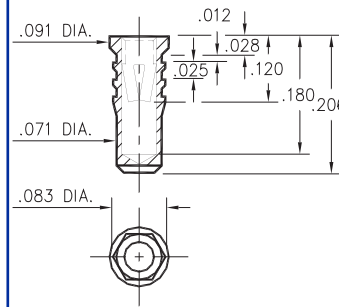

0328-0-15-XX-34-XX-10-0
Hex press-fit in .079 plated thru hole

0334

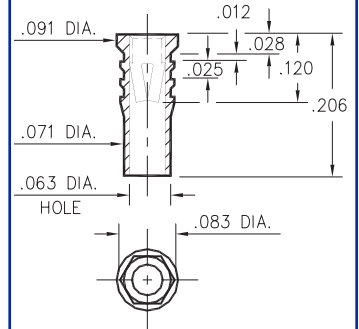

0334-0-15-XX-34-XX-10-0
Hex press-fit in .079 plated thru hole

0312

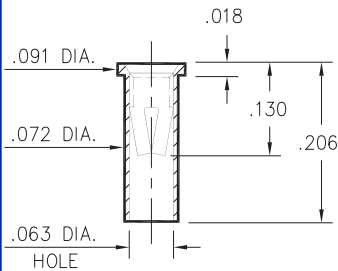

0312-0-15-XX-34-XX-10-0
Solder mount in .075 min. mounting hole

0333

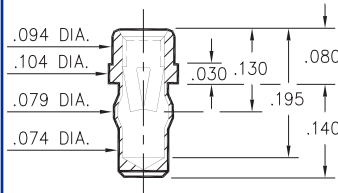

0333-0-42-XX-34-XX-10-0
Press-fit in .076 mounting hole

0357

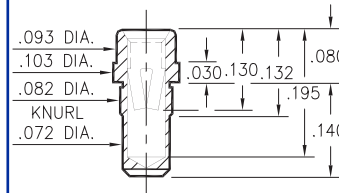

0357-0-15-XX-34-XX-10-0
Press-fit in .078 mounting hole

0317

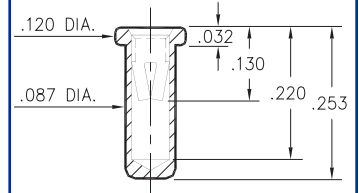

0317-0-15-XX-34-XX-10-0
Solder mount in .091 min. mounting hole

0340

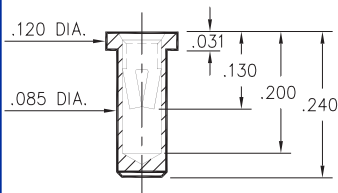

0340-0-15-XX-34-XX-10-0
Solder mount in .087 min. mounting hole

0345

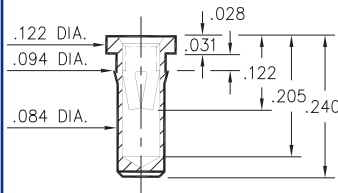

0345-0-15-XX-34-XX-10-0
Press-fit in .089 mounting hole

0316

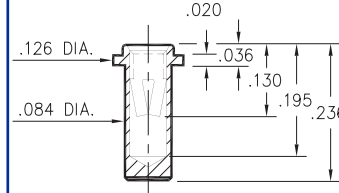

0316-0-15-XX-34-XX-10-0
Solder mount in .087 min. mounting hole

0314

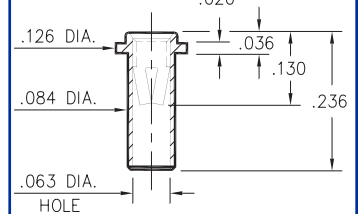

0314-0-15-XX-34-XX-10-0
Solder mount in .087 min. mounting hole

SPECIFICATIONS

SHELL MATERIAL:
Brass Alloy 360, 1/2 Hard

CONTACT MATERIAL:
Beryllium Copper Alloy 172, HT

DIMENSION IN INCHES
TOLERANCES ON:
LENGTHS: ±.005
DIAMETERS: ±.002
ANGLES: ± 2°

ORDER CODE: XXXX - X - XX - XX - 34 - XX - 10 - 0

BASIC PART #

SPECIFY SHELL FINISH:
01 200µ" TIN/LEAD OVER NICKEL
80 200µ" TIN OVER NICKEL
15 10µ" GOLD OVER NICKEL

SPECIFY CONTACT FINISH:
01 200µ" TIN/LEAD OVER NICKEL
80 200µ" TIN OVER NICKEL
27 30µ" GOLD OVER NICKEL



CONTACT

#34 CONTACT (DATA ON PAGE 222)