

SLIDE SWITCHES (SMD)

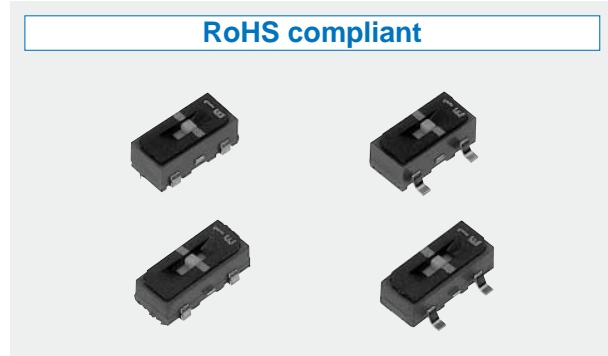

RoHS compliant

FEATURES

- RoHS compliant
- Easy to set slider with line marking
- With neutral detent type lined up to 1 pole 2contacts switch
- Compatible with most automatic pick & place machinery
- Compact and space saving SMD type

INTERNAL STRUCTURE

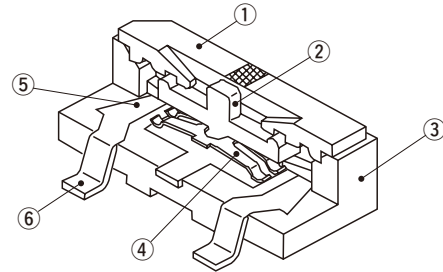

Part name	Material	Flammability
① Cover	Polyphenylenesulphide	UL-94V-0
② Slider	Polyamide	
③ Housing	Polyphenylenesulphide	
④ Slider contact	Copper alloy, Gold-plated	—
⑤ Fixed contact		
⑥ Terminal pin		

CFCs, Halon, Carbon tetrachloride and designated bromic flame retardant PBBs and PBBs are not used in our products.

PART NUMBER DESIGNATION

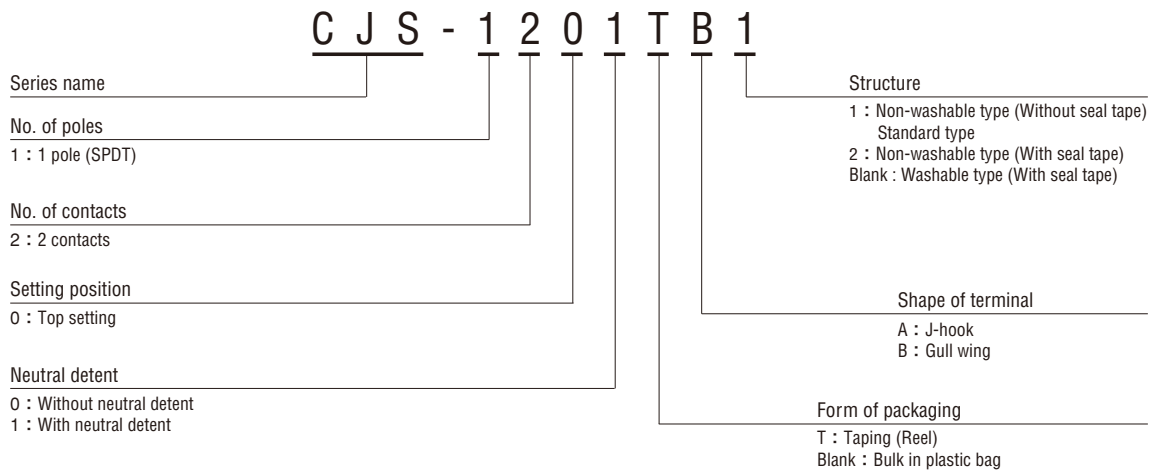

**■ LIST OF PART NUMBERS**

No. of poles	No. of contacts	Setting position	Neutral detent	Form of packaging	Non-washable type (Without seal tape)		Non-washable type (With seal tape)		Pieces in package
					A ( J-hook )	B ( Gull wing )	A ( J-hook )	B ( Gull wing )	
1	2	Top setting	Without neutral detent	Taping	CJS-1200TA1	CJS-1200TB1	CJS-1200TA2	CJS-1200TB2	1000pcs./reel
				Plastic bag	CJS-1200A1	CJS-1200B1	CJS-1200A2	CJS-1200B2	100pcs./pack
			With neutral detent	Taping	CJS-1201TA1	CJS-1201TB1	CJS-1201TA2	CJS-1201TB2	1000pcs./reel
				Plastic bag	CJS-1201A1	CJS-1201B1	CJS-1201A2	CJS-1201B2	100pcs./pack

No. of poles	No. of contacts	Setting position	Neutral detent	Form of packaging	Washable type (With seal tape)		Pieces in package
					A ( J-hook )	B ( Gull wing )	
1	2	Top setting	Without neutral detent	Taping	CJS-1200TA	CJS-1200TB	1000pcs./reel
				Plastic bag	CJS-1200A	CJS-1200B	100pcs./pack
			With neutral detent	Taping	CJS-1201TA	CJS-1201TB	1000pcs./reel
				Plastic bag	CJS-1201A	CJS-1201B	100pcs./pack

※ Verify the above part numbers when placing orders.  
Taping version can be supplied only in reel unit.

**STANDARD SPECIFICATIONS**

Operating temp. range	- 40 ~ 85 °C
Storage temp. range	
Sealing	Washable type available with seal tape
Net weight	Approx. 0.05g (CJS-1200) Approx. 0.06g (CJS-1201)

**ELECTRICAL CHARACTERISTICS**

Contact rating Non-switching Switching Minimum	DC50 V 100 mA DC6 V, 100 mA DC24 V, 25 mA DC20 mV 1 μA
Contact resistance	100 mΩ maximum
Insulation resistance	100 MΩ (DC100 V) minimum
Dielectric strength	AC250 V, 60 s

**MECHANICAL CHARACTERISTICS**

Operating force	5.9 N {0.6 kgf} maximum
Stop strength	10 N {1.02 kgf}, 60 s
Solderability	245 ± 3 °C, 2 ~ 3 s
Soldering heat	Reflow : 255 °C (Peak temperature) (Please refer to the profile below)
	Manual soldering : 350 ± 10 °C, 3 ~ 4 s
Shear (Adhesion)	5 N {0.51 kgf} 10 s
Substrate bending	Width 90 mm, bend 3 mm, 5 s, 1 time
Pull-off strength	5 N {0.51 kgf} 10 s

**ENVIRONMENTAL CHARACTERISTICS**

Vibration	Amplitude 1.5 mm or Acceleration 98 m/s <sup>2</sup> , 10-500 Hz, 3 directions for 10 cycles each
Shock	490 m/s <sup>2</sup> , 11 ms 6 directions for 3 times each
Load life	Continuous load 200 cycles, DC6 ± 0.5 V, 100 ± 10 mA
Humidity	-10 ~ 65 °C, Relative humidity 0 ~ 96 %, 24 h for 10 cycles
High temp. exposure	85 °C, 96 h
Low temp. exposure	-40 °C, 96 h
Thermal shock	-40 (0.5 h) ~ 85 °C (0.5 h), 5 cycles

{ } : Reference only

**Reflow profile for soldering heat evaluation**

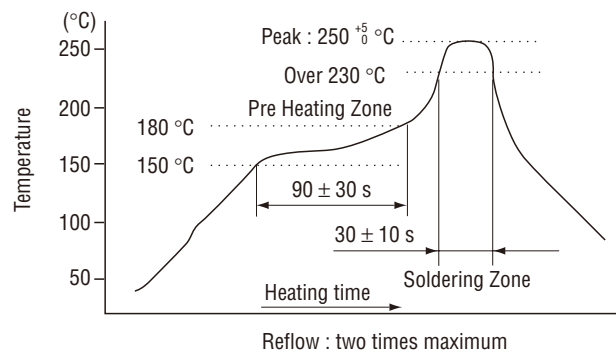

### OUTLINE DIMENSIONS

Unless otherwise specified, tolerance : ± 0.3 (Unit : mm)

#### ● CJS-1200A1

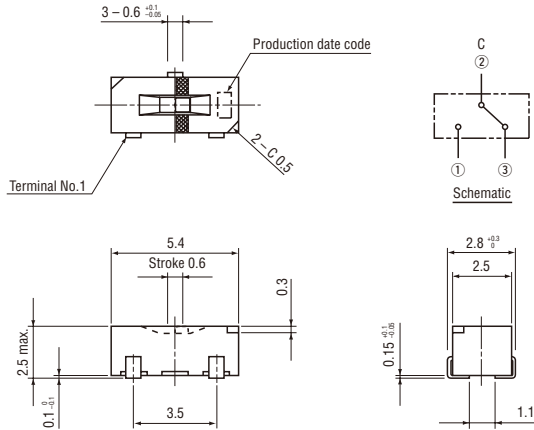

#### ● CJS-1200B1

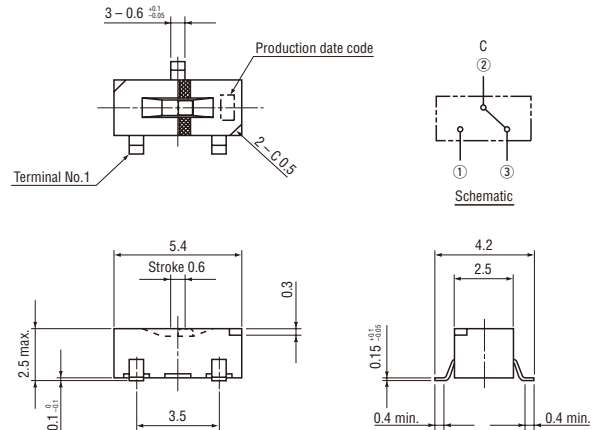

#### ● CJS-1201A1

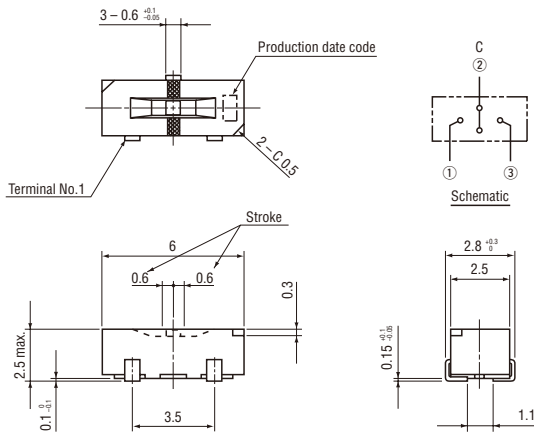

#### ● CJS-1201B1

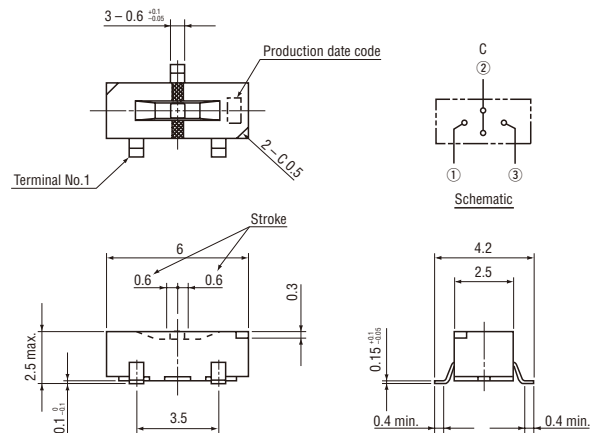

### RECOMMENDED P.C.B. PAD OUTLINE DIMENSIONS

#### A type

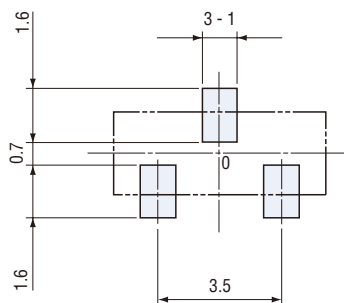

#### B type

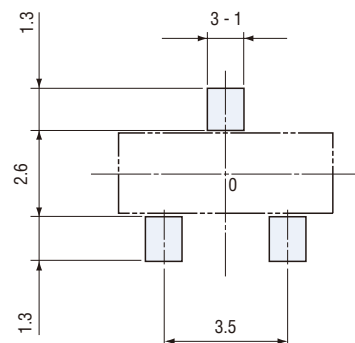

(Unit : mm)

Note) The zero point is the center of mounting.

**PACKAGING SPECIFICATIONS**

**<Taping packaging specifications>**

- Taping version is packaged in 1000 pcs. per reel.  
Orders will be accepted for units of 1000 pcs., i.e., 1000, 2000, 3000 pcs., etc.
- Taping version is boxed with two reels (2000 pcs.).

Maximum number of consecutive missing pieces=2  
Leader length and reel dimension are shown in the diagrams below:

**● Embossed tape dimensions**

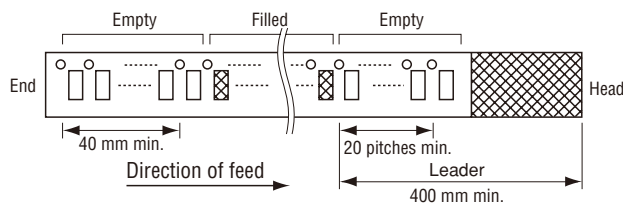

**● Reel dimensions**

(Unit: mm)  
(Conforms to JIS C 0806)

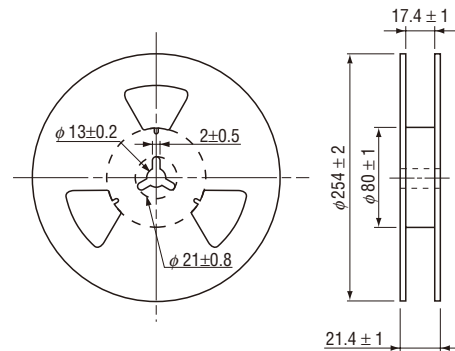

**● CJS-1200TA□, 1200TB□, 1201TA□, 1201TB□**

(Unit: mm)  
(Conforms to JIS C 0806)

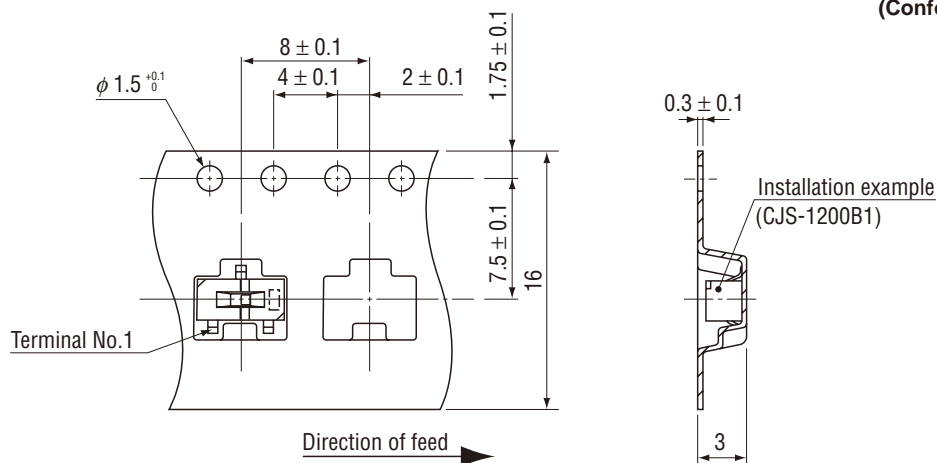

**<Bulk pack specifications>**

- Boxing of bulk pack in a plastic bag is performed with 100 pcs. (standard 500 pcs.) per box.