



**Stud Thyristor**

## Line Thyristor

### SKT 55

#### Features

- Hermetic metal case with glass insulator
- Threaded stud ISO M12
- International standard case

#### Typical Applications

- DC motor control  
(e. g. for machines tools)
- Controlled rectifiers  
(e. g. for battery charging)
- AC controllers  
(e. g. for temperature control)
- Recommended snubber network  
e. g. for  $V_{VRMS} \leq 400$  V:  
 $R = 47 \cdot 10$  W,  $C = 0,22 \cdot F$

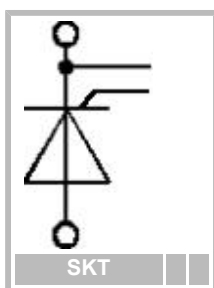

$V_{RSM}$	$V_{RRM}, V_{DRM}$	$I_{TRMS} = 110$ A (maximum value for continuous operation)
V	V	$I_{TAV} = 55$ A (sin. 180; $T_c = 92$ °C)
500	400	SKT 55/04D
700	600	SKT 55/06D
900	800	SKT 55/08D
1300	1200	SKT 55/12E
1500	1400	SKT 55/14E
1700	1600	SKT 55/16E
1900	1800	SKT 55/18E

Symbol	Conditions	Values	Units
$I_{TAV}$	sin. 180; $T_c = 100$ (85) °C	47 ( 63 )	A
$I_D$	K3; $T_a = 45$ °C; B2 / B6	42 / 60	A
	K1,1; $T_a = 45$ °C; B2 / B6	76 / 110	A
$I_{RMS}$	K3; $T_a = 45$ °C; W1C	46	A
$I_{TSM}$	$T_{vj} = 25$ °C; 10 ms	1300	A
	$T_{vj} = 130$ °C; 10 ms	1100	A
$i^2t$	$T_{vj} = 25$ °C; 8,35 ... 10 ms	8500	A <sup>2</sup> s
	$T_{vj} = 130$ °C; 8,35 ... 10 ms	6000	A <sup>2</sup> s
$V_T$	$T_{vj} = 25$ °C; $I_T = 200$ A	max. 1,8	V
$V_{T(TO)}$	$T_{vj} = 130$ °C	max. 0,9	V
$r_T$	$T_{vj} = 130$ °C	max. 4	m•
$I_{DD}; I_{RD}$	$T_{vj} = 130$ °C; $V_{RD} = V_{RRM}; V_{DD} = V_{DRM}$	max. 25	mA
$t_{gd}$	$T_{vj} = 25$ °C; $I_G = 1$ A; $di_G/dt = 1$ A/ $\mu$ s	1	$\mu$ s
$t_{gr}$	$V_D = 0,67 \cdot V_{DRM}$	2	$\mu$ s
$(di/dt)_{cr}$	$T_{vj} = 130$ °C	max. 50	A/ $\mu$ s
$(dv/dt)_{cr}$	$T_{vj} = 130$ °C ; SKT ...D / SKT ...E	max. 500 / 1000	V/ $\mu$ s
$t_q$	$T_{vj} = 130$ °C	100	$\mu$ s
$I_H$	$T_{vj} = 25$ °C; typ. / max.	150 / 250	mA
$I_L$	$T_{vj} = 25$ °C; typ. / max.	300 / 600	mA
$V_{GT}$	$T_{vj} = 25$ °C; d.c.	min. 3	V
$I_{GT}$	$T_{vj} = 25$ °C; d.c.	min. 150	mA
$V_{GD}$	$T_{vj} = 130$ °C; d.c.	max. 0,25	V
$I_{GD}$	$T_{vj} = 130$ °C; d.c.	max. 10	mA
$R_{th(j-c)}$	cont.	0,4	K/W
$R_{th(j-c)}$	sin. 180	0,47	K/W
$R_{th(j-c)}$	rec. 120	0,53	K/W
$R_{th(c-s)}$		0,08	K/W
$T_{vj}$		- 40 ... + 130	°C
$T_{stg}$		- 55 ... + 150	°C
$V_{isol}$		-	V~
$M_s$	to heatsink	10	Nm
$a$		5 * 9,81	m/s <sup>2</sup>
$m$	approx.	65	g
Case		B 5	

## Diagrams

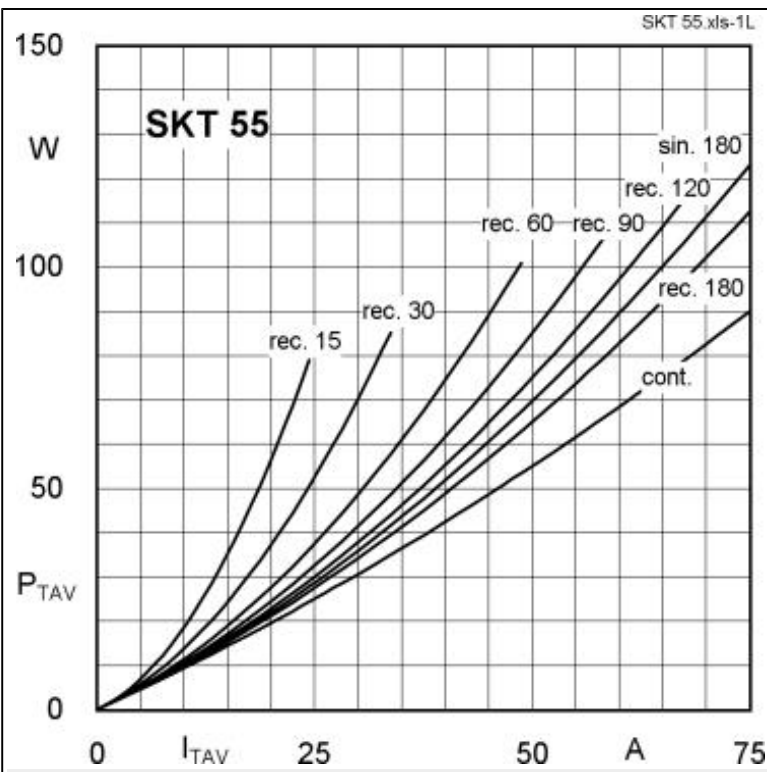

Fig. 1L Power dissipation vs. on-state current

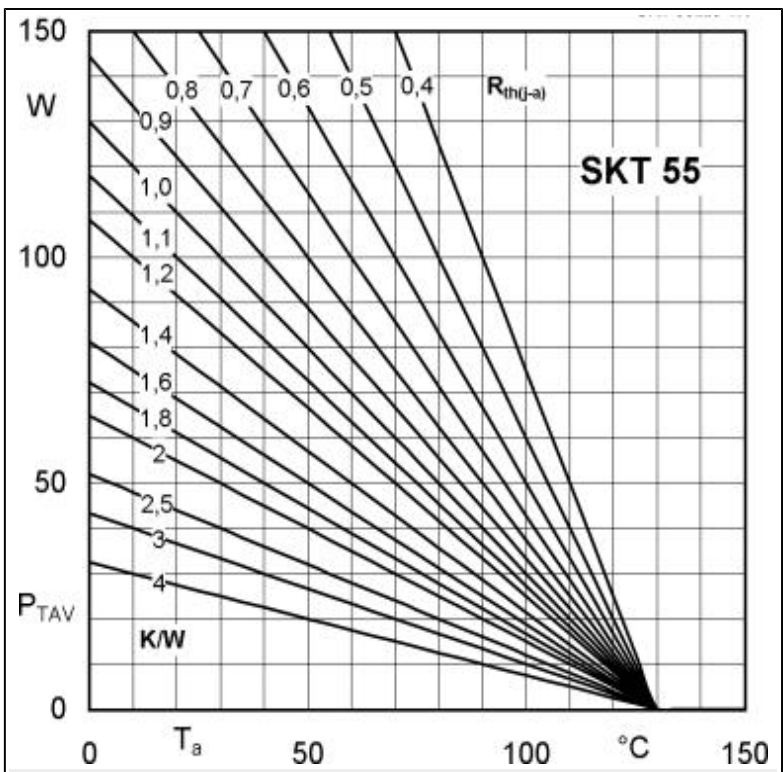

Fig. 1R Power dissipation vs. ambient temperature

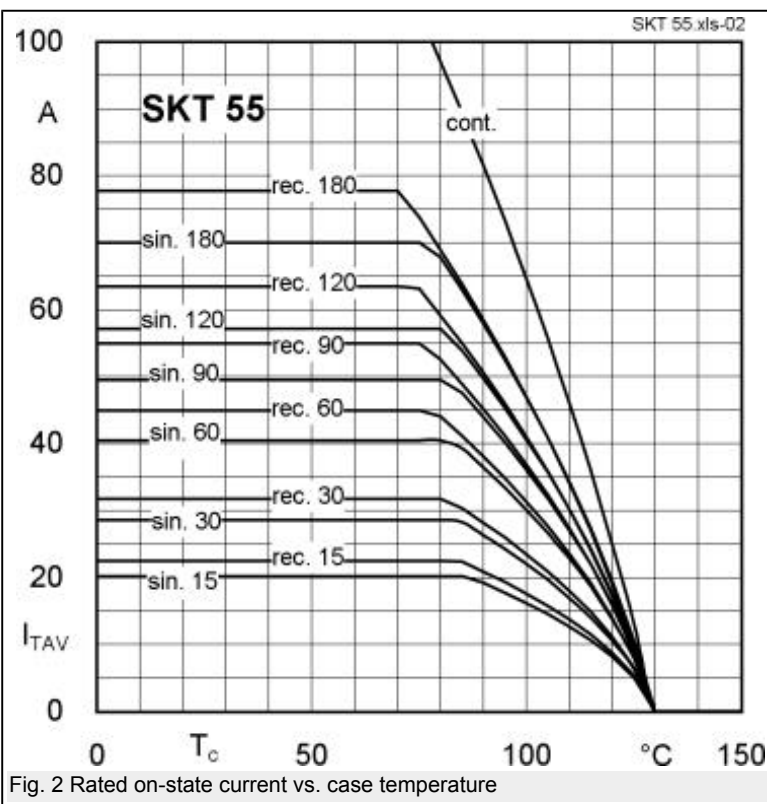

Fig. 2 Rated on-state current vs. case temperature

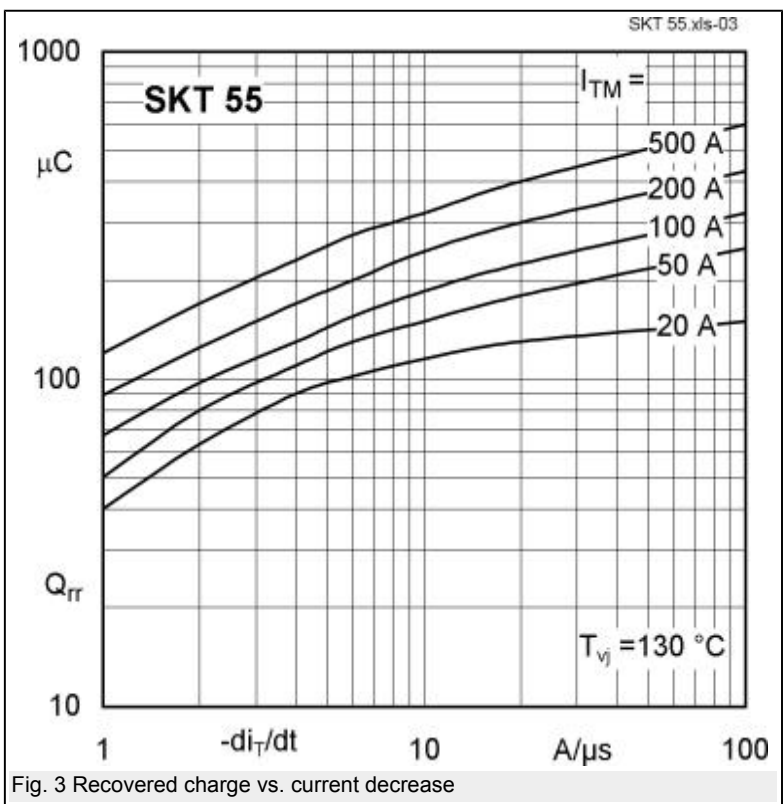

Fig. 3 Recovered charge vs. current decrease

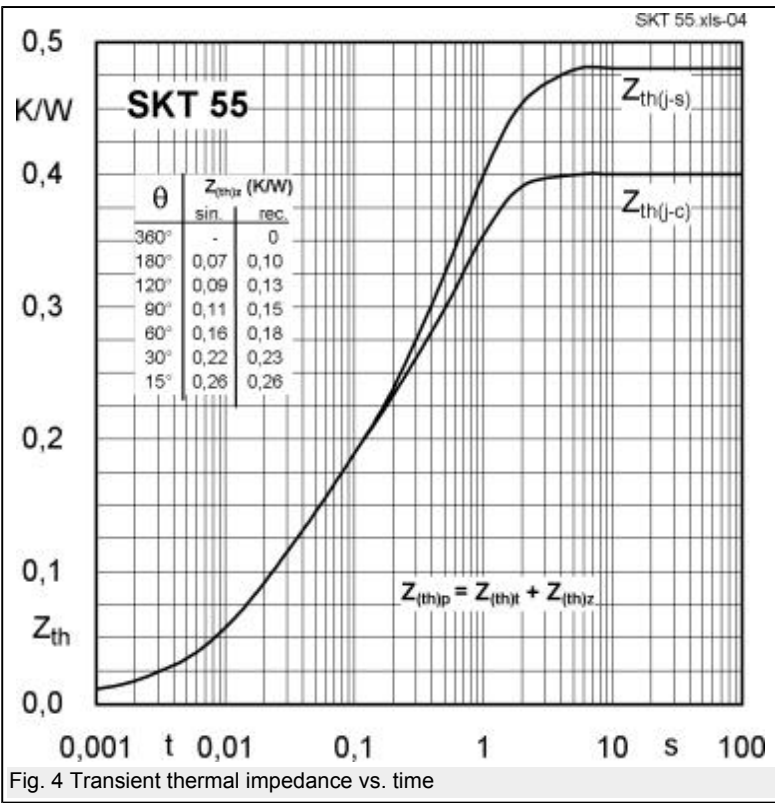

Fig. 4 Transient thermal impedance vs. time

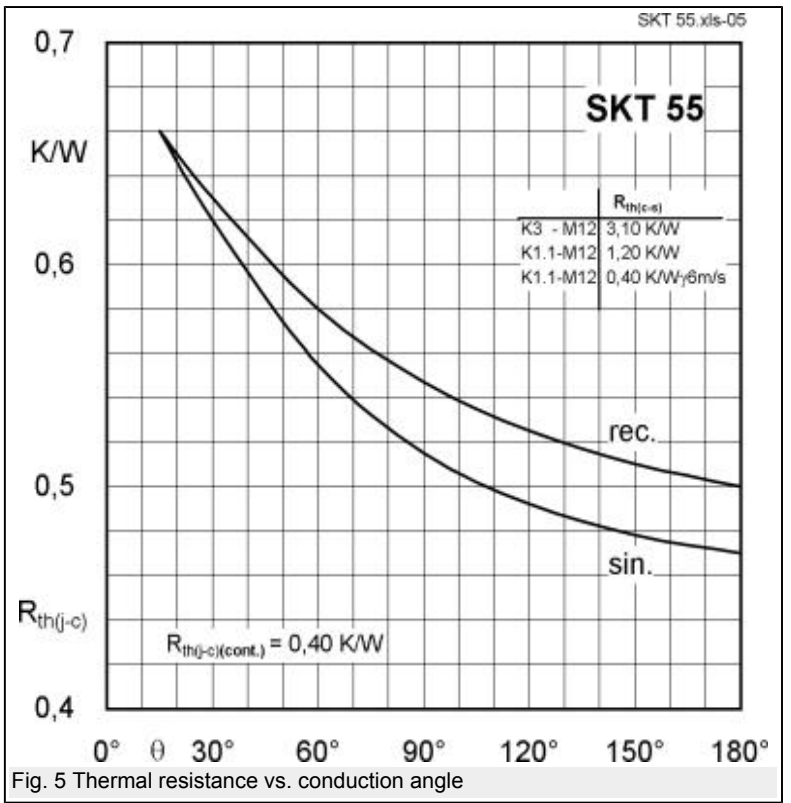

Fig. 5 Thermal resistance vs. conduction angle

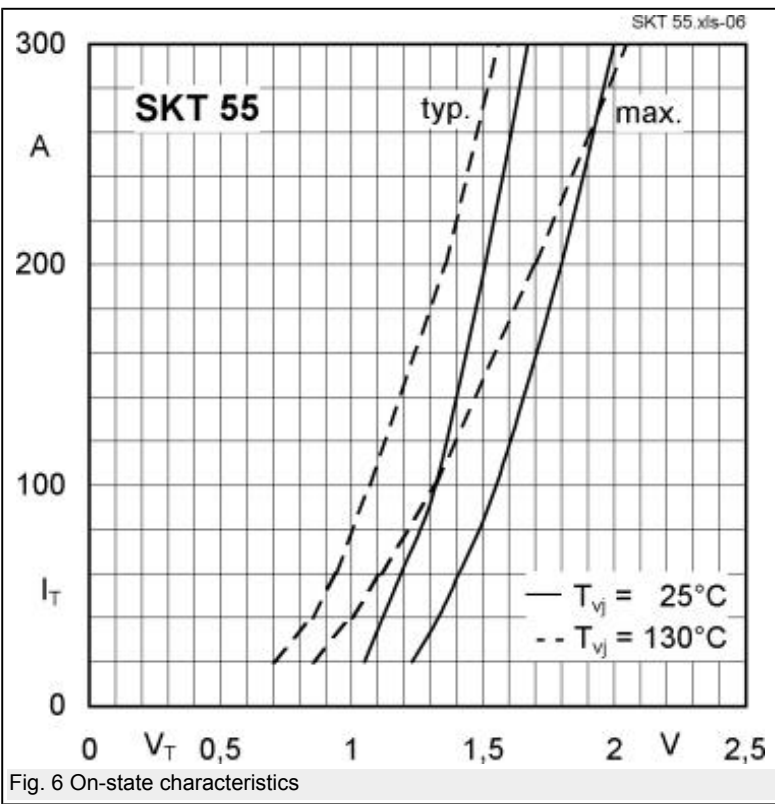

Fig. 6 On-state characteristics

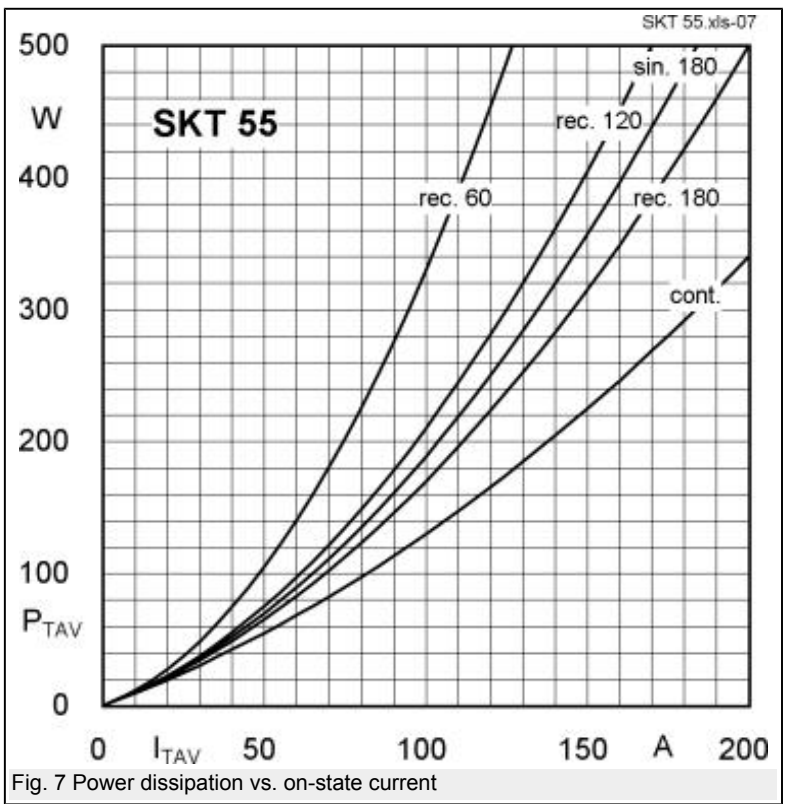

Fig. 7 Power dissipation vs. on-state current

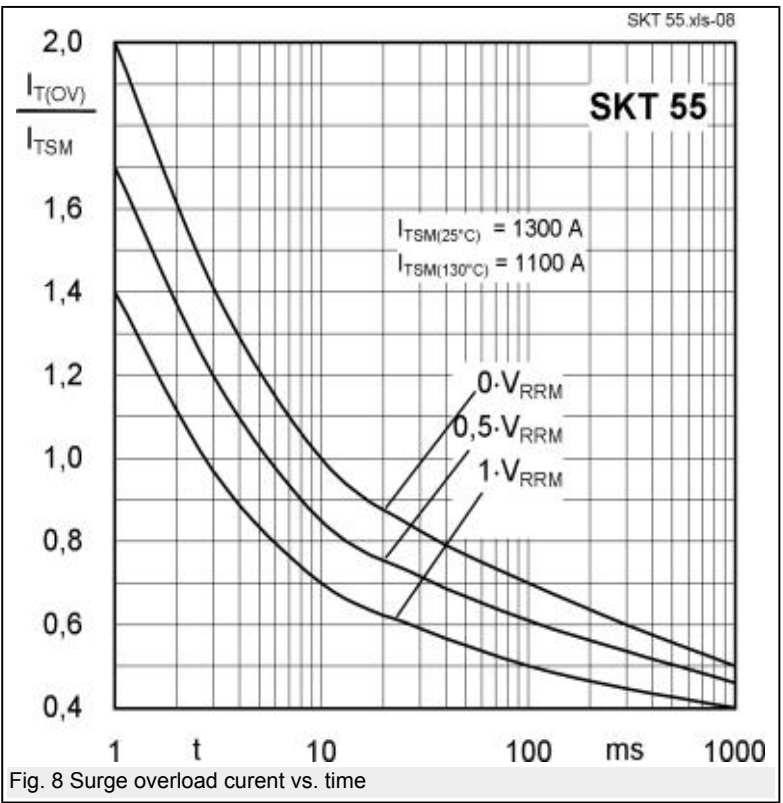

Fig. 8 Surge overload current vs. time

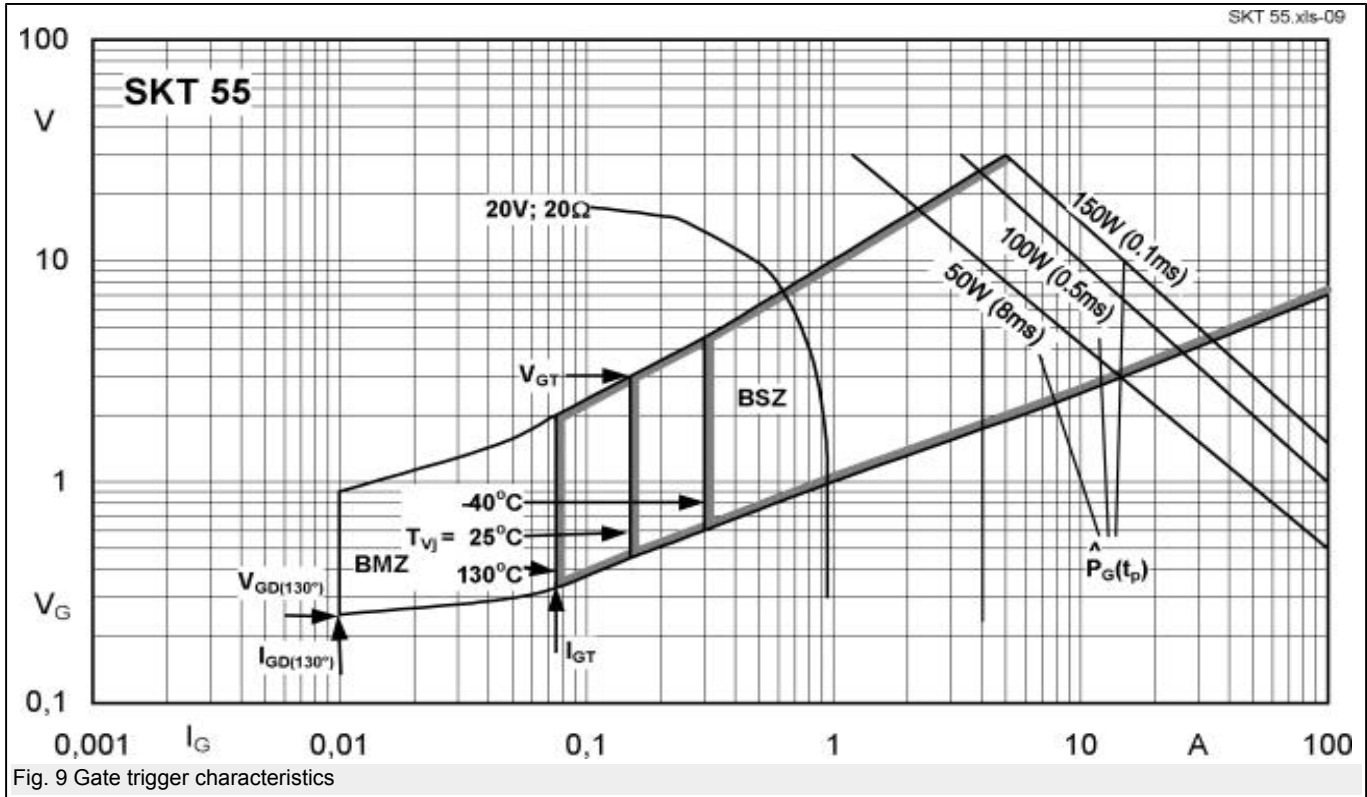
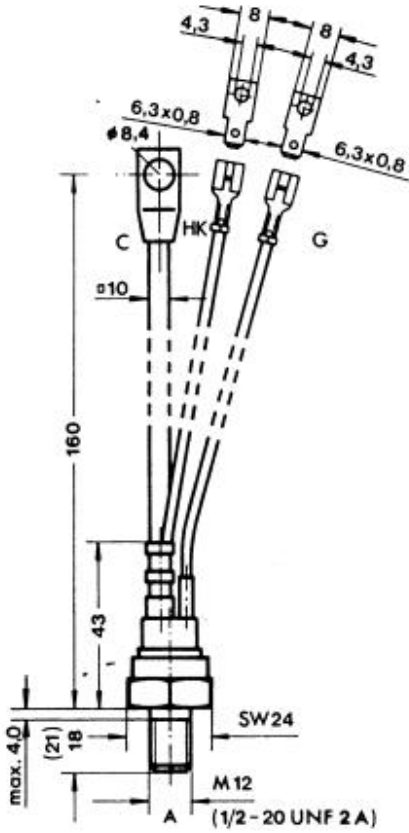

Fig. 9 Gate trigger characteristics

## Cases / Circuits

Dimensions in mm



Case B 5 (IEC 60191-2: A12MA, A12U; JEDEC: TO209 (TO94))

This technical information specifies semiconductor devices but promises no characteristics. No warranty or guarantee expressed or implied is made regarding delivery, performance or suitability.