



Part Number Search

- [Home](#)
- [Company Overview](#)
- [Products](#)
- [Technical Help](#)
- [Contact Us](#)
- [Legal](#)
-
- [Order-On-Line, Application Notes, On-Line Services](#)

- MOTORS
 - Brushless DC
 - Synchronous
 - Stepping
 - Hybrid Stepper
 - Induction
 - Brushed DC
 - Linear

CONTROLLERS

CAPACITORS



SYNCHRONOUS MOTOR FAMILY

Series PA, PB Geared Synchronous Motor



The PA and PB geared motors are the work horses of the Hurst product line. All gears are hobbled to AGMA 7 standards. Pinions are extruded from a special steel with a modified long addendum tooth form to provide higher strength. Both pinions and gear teeth are case hardened and rotate upon hardened and ground steel studs. Synthetic lubrication is used throughout.

Gearing is scaled to provide a maximum gear train loading of 200 ounce-inches.

Note:

- Sleeve bearings are standard. Ball bearings may be specified.

PA, PB Geared

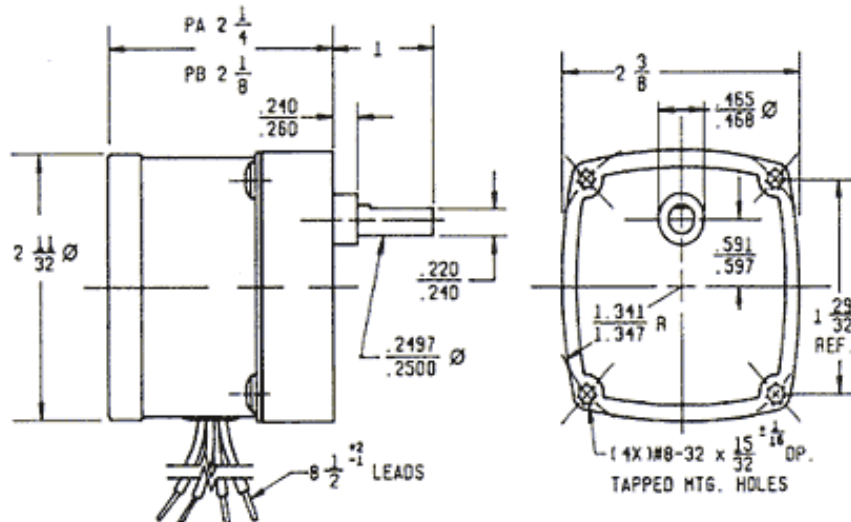

*Dimensions are in inches

Wiring Diagram

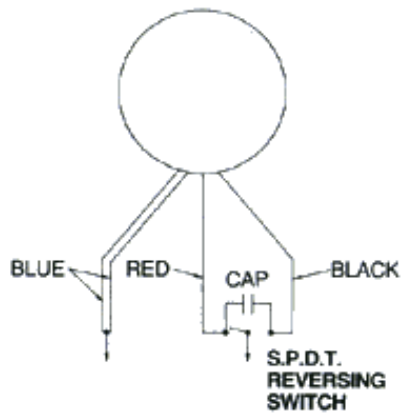

Current applied to the blue and red leads produces CW rotation. Switching the current to the blue and black leads produces CCW rotation. For dual speed versions switching the current produces a change in speed but not in direction of rotation. Direction of rotation must be specified separately.

[Change to Metric](#)

[View Printable Format \(Data Sheet\)](#)

[View Printable Format \(Parts Table\)](#)

To purchase one of the motors listed below, you must be logged into your MyHurst account, then simply click the part number to add the item to your Shopping Cart!

Model	Part Number	Reduction	Rated Torque @ 175 p/s (oz-in)	Holding Torque (oz-in)	Detent Torque (oz-in)	Output Speed (RPM)	Maximum gear train loading	Input Power (watts)	Voltage (VAC) 60HZ	Capacitor Value (mfd)	Shaft bearing	Weight (oz)
PA	3202-017	30	126			10	X	7.5	115	0.68	sleeve	18