

THIS COPY IS PROVIDED ON A RESTRICTED BASIS AND IS NOT TO BE USED IN ANY WAY DETRIMENTAL TO THE INTERESTS OF PANDUIT CORP.

NOTES:

1. MATERIAL:
BODY - CASTED BRONZE
SCREW - SILICON BRONZE
2. DIRECT BURIAL
3. LISTED PER UL 467, CSA CERTIFIED
4. DIMENSIONS IN PARENTHESIS ARE MILLIMETERS.



CERTIFIED

PANUIT PART NUMBER	GROUND ROD SIZE	WIRE RANGE COPPER	INSTALLATION TOOL	DIMENSIONS - IN [mm]		
				W	H	A
WB12-L	1/2 INCH	2-10 AWG STR 10 AWG SOL	1/2 INCH HEX WRENCH	0.84 [21.3]	1.28 [32.5]	0.88 [22.4]
WB34-X	5/8 INCH 3/4 INCH	1/0 - 8 AWG STR 2 - 8 AWG STR	1/2 INCH HEX WRENCH	1.06 [26.9]	1.54 [39.1]	1.03 [26.2]
WB58-Q	5/8 INCH	1/0 - 8 AWG STR	1/2 INCH HEX WRENCH	0.92 [23.4]	1.40 [35.6]	1.04 [26.4]

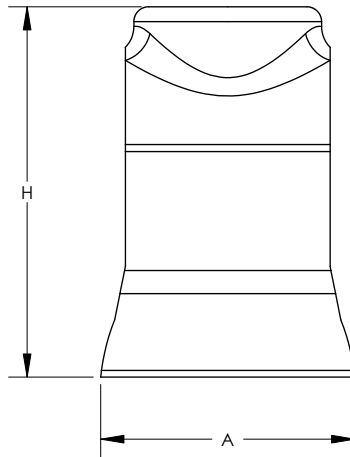
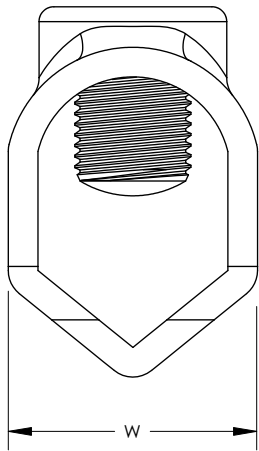

				PANDUIT CORP. TINLEY PARK, ILLINOIS			
01	2/08	JHNU	JHNU	REVISED NOTES CONVERTED DRAWING TO SOLIDWORKS	GROUND ROD CLAMP - WB SERIES (WB12-L, WB34-X, WB58-Q) CUSTOMER DRAWING		
00	12/03	SRB		RELEASED			
REV	DATE	BY	CHK	DESCRIPTION	ECN	SCALE	DRAWING NO / CAD FILE
						N/A	C41399_01