

- Industry Standard Package and Circuits
- Power Control Building Blocks

Modules come in an industry standard package, offering nine circuits that can be used singly or as power control building blocks. All models feature highly efficient thermal management for greatly extended cycle life and are UL recognized (file no. E72445). Manufactured in Crydom's ISO 9001 Certified facility for optimum product performance and reliability.

## PART NUMBER IDENTIFICATION

Series Type	Current	Circuit Type	Voltage
F18 -Case style	27 - 25 Amps	(see schematic diagrams)	400 - 120 Vac
	42 - 40 Amps	Example: SD	600 - 240 Vac
	57 - 55 Amps		1000 - 380 Vac
	92 - 90 Amps		1200 - 480 Vac
	107 - 105 Amps		1400 - 530 Vac
			1600 - 600 Vac

Example: F1892SD1200

## ELECTRICAL SPECIFICATIONS ①

SYMBOL	SPECIFICATION	27	42	57	92	107 ②
$I_D$	Maximum DC Output Current (Tc = 85°C) [A]	25	40	55	90	105
$V_F$	Maximum Voltage Drop	1.55V @ 75A <sub>pk</sub>	1.4V @ 120A <sub>pk</sub>	1.4V @ 165A <sub>pk</sub>	1.4V @ 270A <sub>pk</sub>	1.65V @ 300A <sub>pk</sub>
$T_J$	Operating Junction Temperature Range	-40°C to +125°C				
di/dt	Critical Rate of Rise of On-State Current @ T <sub>J</sub> =125°C [A/μs]	100	100	100	100	100
dv/dt	Critical Rate of Rise of Off-State Voltage [V/μs]	1000	1000	1000	1000	1000
$V_{RRM}$	Repetitive Peak Reverse Voltage (AC Line Nominal) [V <sub>pk</sub> ]	400 (120 Vac) 600 (240 Vac) 1000 (380 Vac) 1200 (480 Vac) 1400 (530 Vac) 1600 (600 Vac)				
$I_{TSM}$	Maximum Non-Repetitive Surge Current (1/2 Cycle, 60Hz) [A]	400	1000	1500	1950	2250
$I^2T$	Maximum $I^2T$ for Fusing (t=8.3ms) [A <sup>2</sup> sec]	670	4150	9350	15800	25000
$I_{GT}$	Maximum Required Gate Current to Trigger @ 25°C [mA]	150	150	150	150	150
$V_{GT}$	Maximum Required Gate Voltage to Trigger @ 25°C [V]	3.0	3.0	3.0	3.0	3.0
$P_{G(AV)}$	Average Gate Power [W]	0.5	0.5	0.5	0.5	0.5
$V_{GM}$	Maximum Peak Gate Voltage (Reverse) [V]	5.0	5.0	5.0	5.0	5.0
$R_{\theta JC}$	Maximum Thermal Resistance Junction to Ceramic Base per Chip [°C/W]	0.4	0.28	0.25	0.14	0.135
$V_{ISOL}$	Isolation Voltage [VRMS]	2500	2500	2500	2500	2500

## MECHANICAL SPECIFICATION

Weight: (typical)	4.75 oz. (135g)
Torque Required	Terminal Stud Screw : 30 inch lb Mounting Screw : 20 inch lb

## GENERAL NOTES

- ① All parameters at 25°C unless otherwise specified.
- ② Available only in SD and SDK circuit configuration.

© 2007 CRYDOM Inc., Specifications subject to change without notice.

- Industry Standard Package and Circuits
- Power Control Building Blocks

**MECHANICAL DIMENSIONS**  
All dimensions are in inches (millimeters)

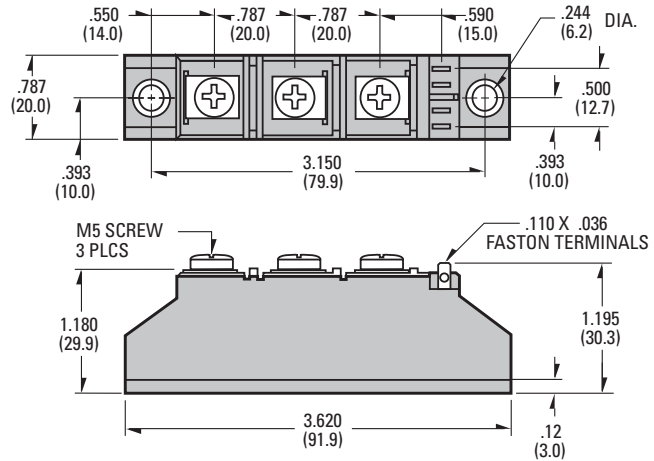

**SERIES F18 CIRCUITS**

