

THESE DRAWINGS ARE THE PROPERTY OF QUALTEK ELECTRONICS AND NOT TO BE REPRODUCED FOR OR COMMUNICATED TO A THIRD PARTY WITHOUT THE EXPRESS WRITTEN PERMISSION OF AN OFFICER OF QUALTEK ELECTRONICS.

REVISION			
REV.	DESCRIPTION	DATE	APPROVED
B	RoHS Compliancy	06-01-06	D.P.
C	Notes Updated	07-26-07	D.P.
D	Notes Updated	08-09-07	D.P.

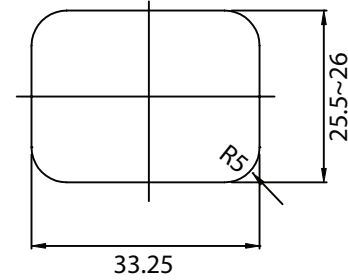
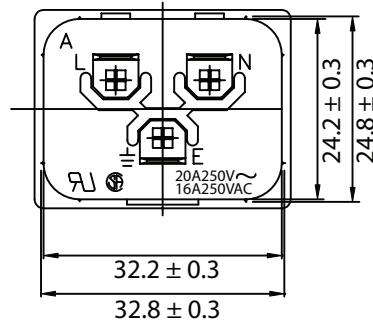
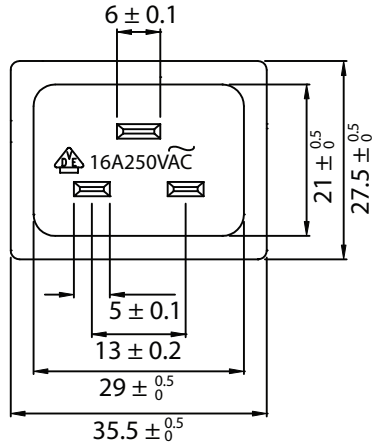
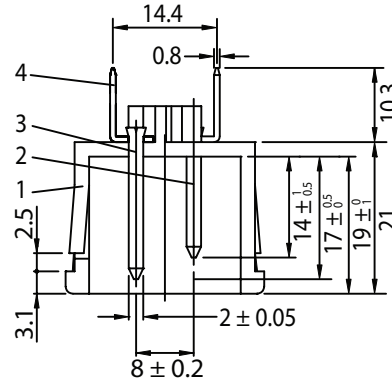
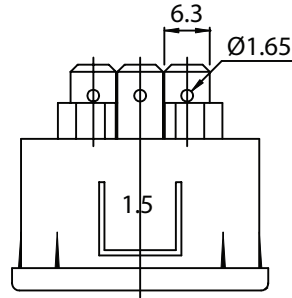

PANEL CUTOUT

**CONTROLLED**

NOTES:

RATING:

UL, CSA: 20A 125V AC/20A 250V AC

VDE: 16A 250V AC

APPROVALS: UL, CSA, VDE

PANEL THICKNESS: 1.5mm

IEC 60320 C20

RoHS COMPLIANT

4	Soldering PIN Bronze Strip t=0.8mm Tin-Plated	3
3	Contact PIN Bronze Strip t=2mm Tin-Plated	2
2	Contact PIN Bronze Strip t=2mm Tin-Plated	1
1	Body Insulator PC 241R Black Color	1

Dim range (mm)	Tolerance +/- (mm)	Qualtek Electronics Corp. PPC DIVISION		
		Part Number:	745W-15/08	RoHS Compliant
0-1	0.15	Description: AC RECEPTACLE		
1-6	0.20			
6-18	0.30			
18-50	0.50			
50-120	0.70	Drawn / Date	Checked / Date	REV. D Approved / Date
120-250	0.90	B.Zhang 06-22-05	06-22-05	JJH / 06-22-05
250-500	1.20			