



Part Number Search

Home

Company Overview

Products



Order-On-Line,  
Application Notes,  
On-Line Services

MOTORS

- Brushless DC
- Synchronous
- Stepping
- Hybrid Stepper
- Induction
- Brushed DC
- Linear

CONTROLLERS

CAPACITORS



## SYNCHRONOUS MOTOR FAMILY

### Series T Geared Synchronous Motor



Reversible, permanent magnet synchronous series T geared motors are available in a wide range of speeds. The gear trains are the most rugged with a maximum recommended loading of 250 ounce inches at 1 RPM. All gears are hobbled to AGMA 7 quality. Pinions are extruded from a special steel with a modified long addendum tooth form to provide higher strength. Pinions are held to the same AGMA 7 quality level as the gears. Both pinion and gear teeth are case hardened for wear resistance and rotate upon hardened and ground steel studs.

Standard motors are 115V, 60Hz but other voltages may be specified. Sleeve bearings are standard. Capacitors are required for operation and must be used in the circuit even if the motor is used in a unidirectional mode.

### T, TA Geared

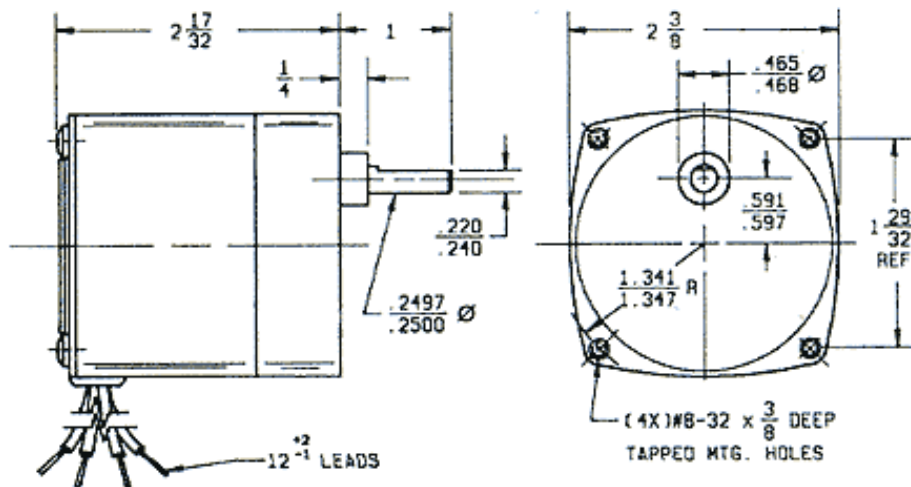

## Wiring Diagram

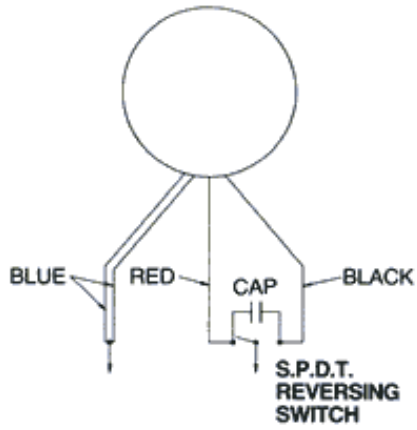

Current applied to the blue and red leads produces CW rotation. Switching the current to the blue and black leads produces CCW rotation.

[Change to Metric](#)

[View Printable Format \(Data Sheet\)](#)

[View Printable Format \(Parts Table\)](#)

To purchase one of the motors listed below, you must be logged into your MyHurst account, then simply click the part number to add the item to your Shopping Cart!

Model	Part Number	Reduction	Rated Torque @ 175 p/s (oz-in)	Holding Torque (oz-in)	Detent Torque (oz-in)	Output Speed (RPM)	Maximum gear train loading	Input Power (watts)	Voltage (VAC) 60HZ	Capacitor Value (mfd)	Shaft bearing	Weight (oz)
T	2602-001	300	250			1	X	7	115	0.68	sleeve	27