

OptoEMU Sensor (Energy Monitoring Unit)

Features

- Monitor real-time energy usage from utility meters, electrical panels, subpanels, and devices
- View detailed real-time and historical energy usage data online through your chosen software service
- Communicate over standard 10/100 Mbps Ethernet or wireless LAN (802.11a, b, or g), or both at once

Description

The OptoEMU Sensor™ Energy Monitoring Unit uses your existing wired or wireless Ethernet network to monitor the electrical energy used in your facility and then deliver that data to online software applications. The OptoEMU Sensor gives you the detailed, real-time data you need to analyze energy consumption and save energy costs.

Why Monitor Energy?

A good manager approves a major expenditure only when he knows exactly where the money is going. Increasingly, commercial and industrial businesses are finding that they can significantly reduce energy costs by managing energy in the same way as other business costs such as people, assets, and inventory. Energy management represents significant opportunities to improve the bottom line.

Saving energy costs does not require complex or expensive technology; it requires basic information. That information starts with gathering detailed, real-time data through the OptoEMU Sensor.

Viewing Energy Data

Real-time and historical energy data gathered by the OptoEMU Sensor is viewed online through a secure software service such as [Google PowerMeter](#) or [Pulse Energy](#). You choose the service that's best for your business. The OptoEMU Sensor sends energy data directly to the service you choose, and you can view the data from any authorized computer or cell phone in accordance with the service you purchase.



OptoEMU Sensor

Connecting to Electrical Devices

The OptoEMU Sensor can connect to a variety of metering devices that emit pulses. It can also connect directly to electrical circuits using current transformers (CTs) with a 0.333 VAC secondary.

The Sensor can monitor energy devices in both ways, simultaneously:

- **Pulse**—The Sensor can monitor up to four electrical devices that emit a pulse output, such as a utility meter or submeter.

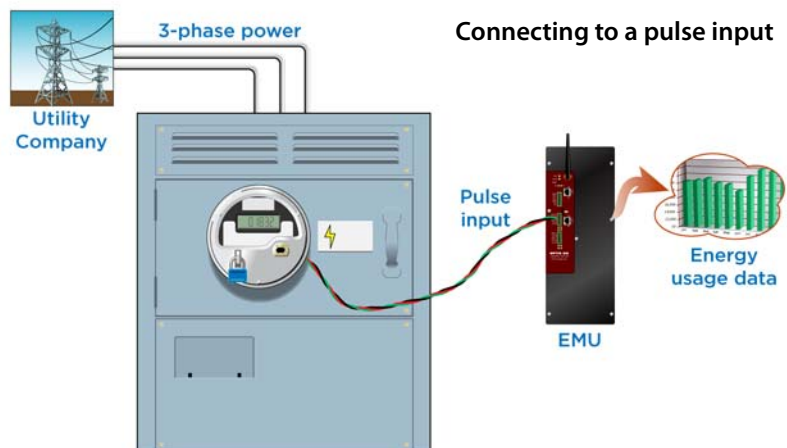

Part Number

Part	Description
OPTOEMU-SNR-3V	Wired+Wireless monitoring unit for electrical panels, machines, and devices
OPTOEMU-PT600	Auxiliary box for OptoEMU Sensor, with stepdown transformer and fusible disconnect

OptoEMU Sensor (Energy Monitoring Unit)

- **Direct**—Using suitable current transformers (CTs) with a 0.333 VAC secondary, the Sensor can monitor voltage and current directly from the main power load panel on a building or facility. It can also monitor loads from individual subpanels or electrical devices such as chillers, boilers, compressors, elevators, and air handling units.

One Sensor can connect to one 3-phase electrical panel or device or to three single-phase panels or devices. The Sensor measures line-to-neutral voltage and is suitable for up to 600 volt systems (346 VAC wye).

Connecting directly to a panel

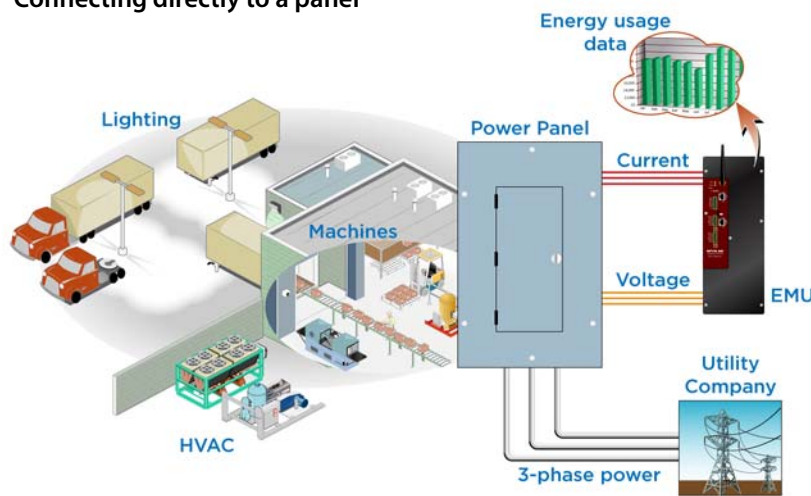

If you need a fusible disconnect or plan to power the Sensor from the monitored panel, an auxiliary box containing a transformer and fusible disconnect is available.

Suitable, safe, easy-to-install CTs with a 0.333 VAC secondary are available through Opto 22. See form #1938, the [Split-Core Current Transformers Data Sheet](#), for more information.

Configuration

The Sensor includes an easy-to-use utility program for assigning an IP address for communication on your network,

configuring the monitored devices, and entering the necessary information to connect to the software service.

Communication

The OptoEMU Sensor uses standard computer networks and protocols to send data to the online software service, which displays energy use to authorized viewers over the Internet.

The OptoEMU Sensor communicates with these services over a standard 10/100 Mbps Ethernet network or over an 802.11a, b, or g wireless LAN (local area network). With two independent Ethernet network interfaces plus an independent wireless interface, the unit gives you the flexibility to monitor devices in hard-to-reach areas and to set up networking suited to your business.

Security on the wireless LAN includes 802.11i WPA2/AES, currently considered the best wireless security, plus the older WPA security standard for backwards compatibility.

Data Storage

The OptoEMU Sensor can store data internally. If communication with the software service is lost, the unit stores data until communication is restored.

Mounting and Wiring

If the OptoEMU Sensor is monitoring voltage and current directly from a panel or device, it should be mounted right next to it. Power for the unit is supplied by a standard 120 VAC or 240 VAC wall outlet. If you need to power the Sensor from a panel or device with higher voltage, also purchase the auxiliary box with transformer and fusible disconnect.

WARNING: Follow all installation instructions in the *OptoEMU User's Guide* to avoid serious or fatal injury or severe damage to equipment. All electrical wiring to the unit must be done by a licensed electrician.

OptoEMU Sensor (Energy Monitoring Unit)

Description (continued)

Data in and data out

OptoEMU Sensor monitors:

Direct voltage and current from:

- Main electrical panel
- Electrical subpanels
- Electrical devices such as chillers, boilers, compressors, elevators, and air handling units (AHUs)

Pulsed outputs from pulsing meter or submeter



OptoEMU Sensor sends data to:

Web energy monitoring applications, such as:

- Google PowerMeter
- Pulse Energy

Wiring for Pulsed Inputs

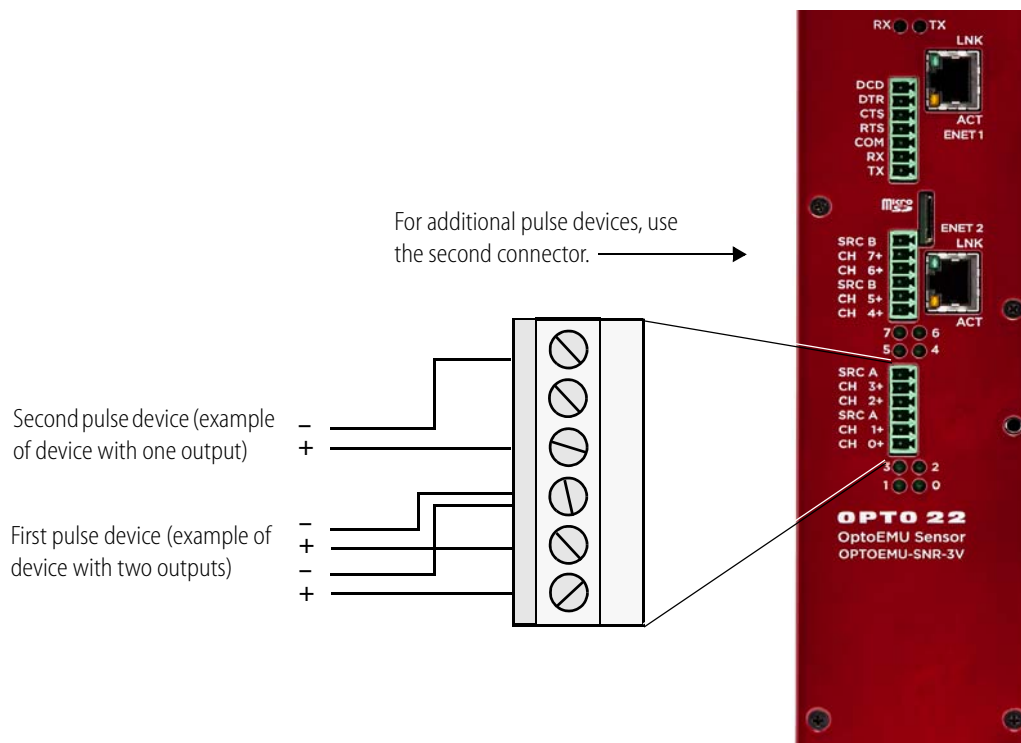

Direct Connection Using CTs

Follow wiring instructions in the unit's user's guide. Wiring must be done by a licensed electrician.

OptoEMU Sensor (Energy Monitoring Unit)

Specifications: OptoEMU Sensor

Overall Unit Specifications

Power Requirements (without auxiliary box)	120/240 VAC (50–60 Hz)
Power Requirements (with auxiliary box)	120/240 VAC (single phase) or 277–346 VAC (line to neutral from 480–600 VAC panels)
Dimensions	6.0" w x 13.5" h x 4.5" d
Enclosure	Sturdy metal enclosure with standard knockouts for wiring
Processor	200 MHz 32-bit ColdFire® 5475 with integrated floating-point unit (FPU)
Memory, Total RAM	32 MB; 2 MB of total available for file storage
Removable storage	MicroSD card slot: supports MicroSD card up to 2 GB maximum
Backup battery	Rechargeable (recharges whenever the unit has power), 3-year power-off data retention
Ethernet Communication (wired)	Two independent 10/100 Mbps Ethernet network interfaces (RJ-45 connectors). Each interface has a separate IP address.
Ethernet Communication (wireless) Topologies Security Frequency 802.11a Frequency 802.11b/g Transmit Power Antenna Connector Roaming	Wireless LAN interface with separate IP address. Infrastructure, Ad-Hoc 802.11i: AES - Compatible with WPA2 Personal; TKIP - Compatible with WPA Personal. Note: TKIP/AES security is not supported in Ad-Hoc mode. 5.180–5.240 GHz, 5.745–5.825 GHz 2.412–2.472 GHz, 2.484 GHz 15 dBm maximum Reverse polarity SMA (RP-SMA or RSMA) Supported within an SSID (Service Set Identifier) only
Serial Communication	One serial port, software configurable for RS-232 (TX, RX, COM, DTR, DCD, RTS, CTS) or RS-485 (2-wire, 4-wire, optional termination, optional biasing)
Indicators	Status of unit Wireless: WLAN activity Serial: Receiving, Transmitting Ethernet interfaces (2): Link, Activity Pulse inputs: On/Off status
Other features	Real-time clock
Operating Temperature	0 to 60 °C (32 to 140° F)
Storage Temperature	-25 to 85 °C (-13 to 185° F)
Humidity	0% to 95% relative humidity, non-condensing
Agency Approvals*	Wireless: U.S., FCC Part 15 Subpart C; Canada, IC RSS-210 UL, CSA, CE, RoHS, DFARS
Warranty	30 months

* UL and CSA approvals pending

(Specifications continue on following page.)

OptoEMU Sensor (Energy Monitoring Unit)

Specifications (continued)

Dry Contact Pulse Inputs

OptoEMU Sensor supplies 15 volts of power to each external dry contact switch and senses switch closure.

Open Circuit Voltage (Switch Open)	15 VDC typical (supplied by OptoEMU Sensor)
Short Circuit Current (Switch Closed)	7 milliamps nominal
Minimum Off Resistance	>20 K ohms
Maximum Allowable On Resistance (Wire + Contact Resistance)	500 ohms
Turn-on Time	5 msec
Turn-off Time	25 msec
Channel-to-channel Isolation	8 channels isolated in groups of two
Input-to-output Isolation	1500 V AC/DC
Status indicators	1 LED per channel

3-Phase Power Monitoring

Voltage Inputs (each voltage channel)	
Input Range	0 to 400 VAC RMS (line to neutral)
Input Over Range	To 440 volts
Resolution	10 mV
Accuracy (47 to 63 Hz)	(When used within recommended range) ± 0.2 V and ± 0.2% reading (at full scale = ± 0.7 V or 0.28%) (-0.2 dB at 660 Hz; -3 dB at 1.89 kHz) nominal
RMS Integration Time/ Data Freshness	1000 ms (synchronous with current measurement)
Input Resistance – Single Ended	1 Megohm NOTE: Because both channels share the same reference terminal, polarity must be observed when connecting the current channel.
Maximum Input	600 V non-operating
Current Inputs (each current channel)	
Input Range	0 to 333 mV AC current transducer input
Input Over Range	To 366 mV AC
Input Overload	5 VAC continuous, non-operating
Resolution	13.3 µV AC
Accuracy (47 to 63 Hz)	± 0.2% reading (at full scale = 0.28%) (-0.2 dB at 660 Hz; -3 dB at 1.89 kHz) nominal
RMS Integration Time/ Data Freshness	1000 ms (synchronous with voltage measurement)
Input Resistance – Single Ended	500 K Ohms NOTE: Because both channels share the same reference terminal, polarity must be observed when connecting the voltage channel.
Maximum Input	5 VAC continuous, non-operating

More About Opto 22

Products

Opto 22 develops and manufactures reliable, flexible, easy-to-use hardware and software products for industrial automation, remote monitoring, and data acquisition applications.

SNAP PAC System

Designed to simplify the typically complex process of understanding, selecting, buying, and applying an automation system, the SNAP PAC System consists of four integrated components:

- SNAP PAC controllers
- PAC Project™ Software Suite
- SNAP PAC brains
- SNAP I/O™

SNAP PAC Controllers

Programmable automation controllers (PACs) are multifunctional, multidomain, modular controllers based on open standards and providing an integrated development environment.

Opto 22 has been manufacturing PACs for many years. The latest models include the standalone SNAP PAC S-series and the rack-mounted SNAP PAC R-series. Both handle a wide range of digital, analog, and serial functions and are equally suited to data collection, remote monitoring, process control, and discrete and hybrid manufacturing.

SNAP PACs are based on open Ethernet and Internet Protocol (IP) standards, so you can build or extend a system without the expense and limitations of proprietary networks and protocols.

PAC Project Software Suite

Opto 22's PAC Project Software Suite provides full-featured and cost-effective control programming, HMI (human machine interface) development and runtime, OPC server, and database connectivity software to power your SNAP PAC System.

These fully integrated software applications share a single tagname database, so the data points you configure in PAC Control™ are immediately available for use in PAC Display™, OptoOPCServer™, and OptoDataLink™. Commands are in plain English; variables and I/O point names are fully descriptive.

PAC Project Basic offers control and HMI tools and is free for download on our website, www.opto22.com. PAC Project Professional, available for separate purchase, adds OptoOPCServer, OptoDataLink, options for Ethernet link redundancy or segmented networking, and support for legacy Opto 22 serial *mistic*™ I/O units.

SNAP PAC Brains

While SNAP PAC controllers provide central control and data distribution, SNAP PAC brains provide distributed intelligence for I/O processing and communications. Brains offer analog, digital, and serial functions, including thermocouple linearization; PID loop control; and optional high-speed digital counting (up to 20 kHz), quadrature counting, TPO, and pulse generation and measurement.

SNAP I/O

I/O provides the local connection to sensors and equipment. Opto 22 SNAP I/O offers 1 to 32 points of reliable I/O per module, depending on the type of module and your needs. Analog, digital, serial, and special-purpose modules are all mixed on the same mounting rack and controlled by the same processor (SNAP PAC brain or rack-mounted controller).

Quality

Founded in 1974 and with over 85 million devices sold, Opto 22 has established a worldwide reputation for high-quality products. All are made in the U.S.A. at our manufacturing facility in Temecula, California. Because we do no statistical testing and each part is tested twice before leaving our factory, we can guarantee most solid-state relays and optically isolated I/O modules for life.

Free Product Support

Opto 22's Product Support Group offers free, comprehensive technical support for Opto 22 products. Our staff of support engineers represents decades of training and experience. Product support is available in English and Spanish, by phone or email, Monday through Friday, 7 a.m. to 5 p.m. PST.

Free Customer Training

Hands-on training classes for the SNAP PAC System are offered at our headquarters in Temecula, California. Each student has his or her own learning station; classes are limited to nine students. Registration for the free training class is on a first-come, first-served basis. See our website, www.opto22.com, for more information or email training@opto22.com.

Purchasing Opto 22 Products

Opto 22 products are sold directly and through a worldwide network of distributors, partners, and system integrators. For more information, contact Opto 22 headquarters at 800-321-6786 or 951-695-3000, or visit our website at www.opto22.com.

www.opto22.com