



semiconductors

company

product

sales network

site index

contact us

semiconductors :: product :: [Standard Gate SCRs](#)

Product: Standard Gate SCRs

Standard SCRs uses a high performance glass passivated technology.

This general purpose Family of Silicon Controlled Rectifiers is designed for power supplies.

Product	Family	$I_{T(RMS)}$	V_{RRM}/V_{DRM} (V)	I_{TSM} (A)	$I_{GT\ min}$ (μA)	$I_{GT\ min}$ (mA)	$I_{GT\ max}$ (μA)	$I_{GT\ max}$ (mA)	$dv/dt_{(min)}$ V/ μs	PACKAGE
FS1610MH	FS16H(StG)	16	600	190	2		25	500		TO220AB

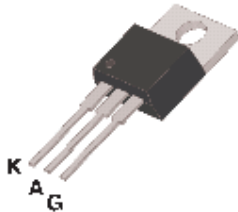
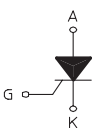

STANDARD SCR

<p>TO-220-AB</p>  <p style="text-align: center;">  </p>	<p style="text-align: center;">On-State Current Gate Trigger Current</p> <p style="text-align: center;">16 Amp 2 mA to 40 mA</p> <p style="text-align: center;">Off-State Voltage</p> <p style="text-align: center;">200 V ÷ 800 V</p> <p>These series of Silicon Controlled Rectifier use a high performance PNP technology.</p> <p>These parts are intended for general purpose applications where high gate sensitivity is required.</p>
---	--

Absolute Maximum Ratings, according to IEC publication No. 134

SYMBOL	PARAMETER	CONDITIONS	Value	Unit
$I_{T(RMS)}$	On-state Current	180° Conduction Angle, $T_c = 110\text{ °C}$	16	A
$I_{T(AV)}$	Average On-state Current	Half Cycle, $\Theta = 180\text{ °}$, $T_c = 110\text{ °C}$	10	A
I_{TSM}	Non-repetitive On-State Current	Half Cycle, 60 Hz	200	A
I_{TSM}	Non-repetitive On-State Current	Half Cycle, 50 Hz	190	A
I^2t	Fusing Current	$t_p = 10\text{ms}$, Half Cycle	180	A ² s
I_{GM}	Peak Gate Current	20 μs max.	4	A
P_{GM}	Peak Gate Dissipation	20 μs max.	10	W
$P_{G(AV)}$	Gate Dissipation	20ms max.	1	W
T_j	Operating Temperature		(-40 to +125)	°C
T_{stg}	Storage Temperature		(-40 to +150)	°C
T_{slid}	Soldering Temperature	10s max.	260	°C
V_{RGM}	Reverse Gate Voltage		5	V

SYMBOL	PARAMETER	CONDITIONS	VOLTAGE					Unit
			B	D	M	S	N	
V_{DRM} V_{RRM}	Repetitive Peak Off State Voltage	$R_{GK} = 1\text{ k}\Omega$	200	400	600	700	800	V

STANDARD SCR

Electrical Characteristics

SYMBOL	PARAMETER	CONDITIONS	SENSITIVITY		Uni	
			10	14		
I_{GT}	Gate Trigger Current	$V_D = 12 V_{DC}, R_L = 33\Omega, T_j = 25^\circ C$	MIN MAX	2 25	4 40	m A
V_{GT}	Gate Trigger Voltage	$V_D = 12 V_{DC}, R_L = 33\Omega, T_j = 25^\circ C$	MAX	1.3		V
V_{GD}	Gate Non Trigger Voltage	$V_D = V_{DRM}, R_L = 3.3k\Omega, R_{GK} = 220\Omega, T_j = 125^\circ C$	MIN	0.2		V
I_H	Holding Current	$I_T = 500 \text{ mA}$	MAX	40	50	mA
I_L	Latching Current	$I_G = 1.2 I_{GT}$	MAX	60	90	mA
dV / dt	Critical Rate of Voltage Rise	$V_D = 0.67 \times V_{DRM}, \text{ Gate open}, T_j = 125^\circ C$	MIN	500	1000	V/ μ s
dI / dt	Critical Rate of Current Rise	$I_G = 2 \times I_{GT}, Tr \leq 100 \text{ ns}, f = 60 \text{ Hz}, T_j = 125^\circ C$	MIN	50		A/ μ s
V_{TM}	On-state Voltage	at $I_T = 32 \text{ Amp}, tp = 380 \mu\text{s}, T_j = 25^\circ C$	MAX	1.6		V
V_{t0}	Threshold Voltage	$T_j = 125^\circ C$	MAX	0.77		V
r_d	Dynamic resistance	$T_j = 125^\circ C$	MAX	23		m Ω
I_{DRM} / I_{RRM}	Off-State Leakage Current	$V_D = V_{DRM}, R_{GK} = 1k\Omega, V_R = V_{RRM}, T_j = 125^\circ C$	MAX	2		mA
			MAX	5		μ A
$R_{th(j-c)}$	Thermal Resistance Junction-Case for DC	for AC 360° conduction angle		1.1		°C/W
$R_{th(j-a)}$	Thermal Resistance Junction-Amb for DC	$S = 1 \text{ cm}^2$		60		°C/W

PART NUMBER INFORMATION

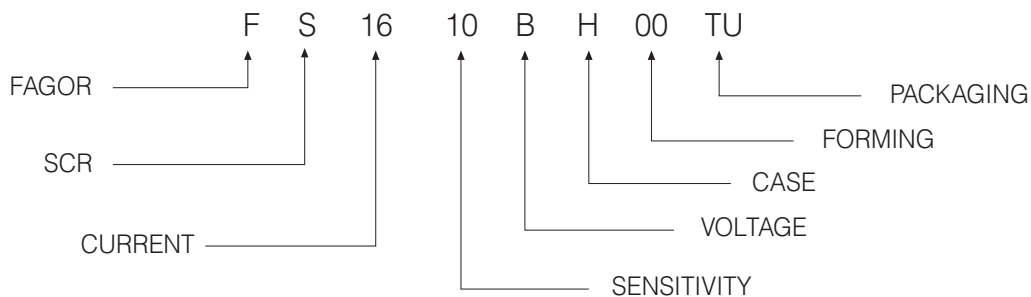

STANDARD SCR

Fig. 7: On-state characteristics (maximum values).

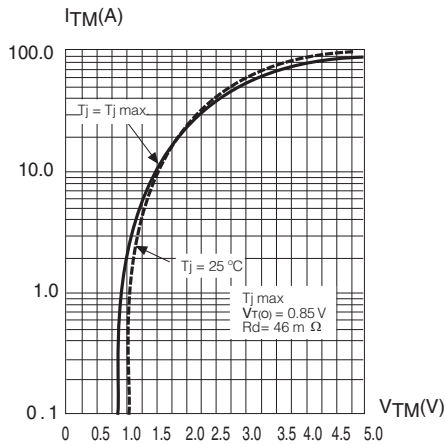

PACKAGE MECHANICAL DATA

TO-220AB

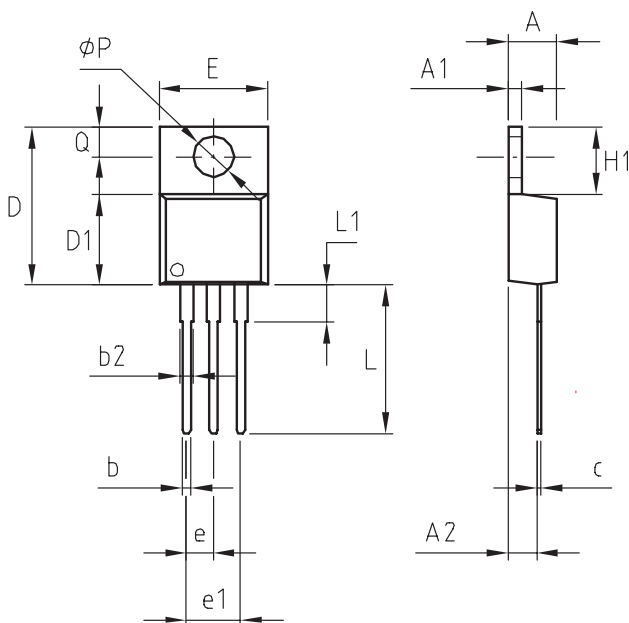

REF.	DIMENSIONS	
	Millimeters	
	Min.	Max.
A	3.56	4.83
A1	0.50	1.40
A2	2.00	2.92
b	0.38	1.02
b2	1.14	1.78
c	0.35	0.61
D	14.22	16.51
D1	8.38	9.02
E	9.65	10.67
e	2.49	2.59
e1	5.03	5.13
H1	5.84	6.86
L	12.70	14.74
L1		6.35
P	3.53	4.09
Q	2.54	3.43

Mounting Torque

1 N.m

(*) Limiting values and life support applications, see Web page.