

1024K I²C™ CMOS Serial EEPROM

Device Selection Table:

Part Number	Vcc Range	Max. Clock Frequency	Temp. Ranges
24AA1025	1.7-5.5V	400 kHz [†]	I
24LC1025	2.5-5.5V	400 kHz [*]	I, E
24FC1025	1.8-5.5V	1 MHz [‡]	I

[†]100 kHz for Vcc < 2.5V

^{*}100 kHz for Vcc < 4.5V, E-temp

[‡]400 kHz for Vcc < 2.5V

Features:

- Low-Power CMOS Technology:
 - Read current 450 μ A, maximum
 - Standby current 5 μ A, maximum
- 2-Wire Serial Interface, I²C™ Compatible
- Cascadable up to Four Devices
- Schmitt Trigger Inputs for Noise Suppression
- Output Slope Control to Eliminate Ground Bounce
- 100 kHz and 400 kHz Clock Compatibility
- 1 MHz Clock for FC Versions
- Page Write Time 3 ms, typical
- Self-Timed Erase/Write Cycle
- 128-Byte Page Write Buffer
- Hardware Write-Protect
- ESD Protection >400V
- More than 1 Million Erase/Write Cycles
- Data Retention >200 Years
- Factory Programming Available
- Packages include 8-lead PDIP, SOIJ
- Pb-Free and RoHS Compliant
- Temperature Ranges:
 - Industrial (I): -40°C to +85°C
 - Automotive (E): -40°C to +125°C

Description:

The Microchip Technology Inc. 24AA1025/24LC1025/24FC1025 (24XX1025*) is a 128K x 8 (1024K bit) Serial Electrically Erasable PROM, capable of operation across a broad voltage range (1.7V to 5.5V). It has been developed for advanced, low-power applications such as personal communications or data acquisition. This device has both byte write and page write capability of up to 128 bytes of data.

This device is capable of both random and sequential reads. Reads may be sequential within address boundaries 0000h to FFFFh and 10000h to 1FFFFh. Functional address lines allow up to four devices on the same data bus. This allows for up to 4 Mbits total system EEPROM memory. This device is available in the standard 8-pin PDIP and SOIJ packages.

Package Type

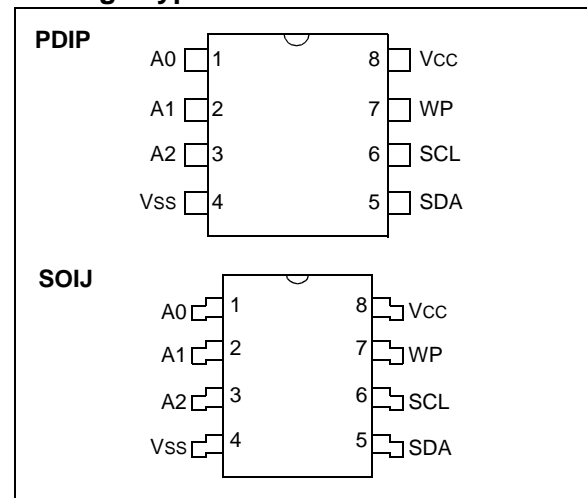

Block Diagram

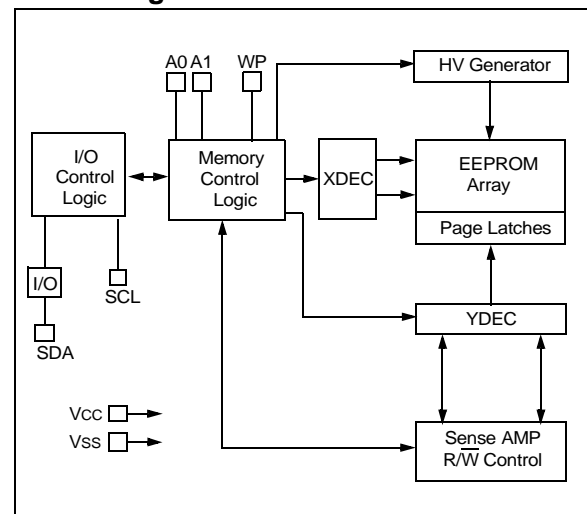

*24XX1025 is used in this document as a generic part number for the 24AA1025/24LC1025/24FC1025 devices.

24AA1025/24LC1025/24FC1025

1.0 ELECTRICAL CHARACTERISTICS

Absolute Maximum Ratings^(†)

V _{CC}	6.5V
All inputs and outputs w.r.t. V _{SS}	-0.6V to V _{CC} +1.0V
Storage temperature	-65°C to +150°C
Ambient temperature with power applied.....	-40°C to +125°C
ESD protection on all pins	≥ 4 kV

† NOTICE: Stresses above those listed under “Absolute Maximum Ratings” may cause permanent damage to the device. This is a stress rating only and functional operation of the device at those or any other conditions above those indicated in the operational listings of this specification is not implied. Exposure to maximum rating conditions for extended periods may affect device reliability.

TABLE 1-1: DC CHARACTERISTICS

DC CHARACTERISTICS			Industrial (I): V _{CC} = +1.7V to 5.5V T _A = -40°C to +85°C Automotive (E): V _{CC} = +2.5V to 5.5V T _A = -40°C to +125°C			
Param. No.	Sym.	Characteristic	Min.	Max.	Units	Conditions
D1		A0, A1, SCL, SDA and WP pins:	—	—	—	
D2	V _{IH}	High-level input voltage	0.7 V _{CC}	—	V	
D3	V _{IL}	Low-level input voltage	—	0.3 V _{CC} 0.2 V _{CC}	V V	V _{CC} ≥ 2.5V V _{CC} < 2.5V
D4	V _{HYS}	Hysteresis of Schmitt Trigger inputs (SDA, SCL pins)	0.05 V _{CC}	—	V	V _{CC} ≥ 2.5V (Note)
D5	V _{OL}	Low-level output voltage	—	0.40	V	I _{OL} = 3.0 mA @ V _{CC} = 4.5V I _{OL} = 2.1 mA @ V _{CC} = 2.5V
D6	I _{LI}	Input leakage current	—	±1	μA	V _{IN} = V _{SS} or V _{CC} , WP = V _{SS} V _{IN} = V _{SS} or V _{CC} , WP = V _{CC}
D7	I _{LO}	Output leakage current	—	±1	μA	V _{OUT} = V _{SS} or V _{CC}
D8	C _{IN} , C _{OUT}	Pin capacitance (all inputs/outputs)	—	10	pF	V _{CC} = 5.0V (Note) T _A = 25°C, F _{CLK} = 1 MHz
D9	I _{CC} Read	Operating current	—	450	μA	V _{CC} = 5.5V, SCL = 400 kHz
	I _{CC} Write		—	5	mA	V _{CC} = 5.5V
D10	I _{CCS}	Standby current	—	5	μA	T _A = -40°C to 85°C SCL = SDA = V _{CC} = 5.5V A0, A1, WP = V _{SS} , A2 = V _{CC}

Note: This parameter is periodically sampled and not 100% tested.

24AA1025/24LC1025/24FC1025

TABLE 1-2: AC CHARACTERISTICS

AC CHARACTERISTICS			Industrial (I): VCC = +1.7V to 5.5V TA = -40°C to +85°C Automotive (E): VCC = +2.5V to 5.5V TA = -40°C to +125°C			
Param. No.	Sym.	Characteristic	Min.	Max.	Units	Conditions
1	FCLK	Clock frequency	— — —	100 400 1000	kHz	1.7V ≤ VCC ≤ 2.5V 2.5V ≤ VCC ≤ 5.5V (Note 5) 2.5V ≤ VCC ≤ 5.5V (Note 6) (24FC1025 only)
2	THIGH	Clock high time	4000 600 500	— — —	ns	1.7V ≤ VCC ≤ 2.5V 2.5V ≤ VCC ≤ 5.5V 2.5V ≤ VCC ≤ 5.5V (Note 6) (24FC1025 only)
3	TLOW	Clock low time	4700 1300 500	— — —	ns	1.7V ≤ VCC ≤ 2.5V 2.5V ≤ VCC ≤ 5.5V 2.5V ≤ VCC ≤ 5.5V (Note 6) (24FC1025 only)
4	TR	SDA and SCL rise time (Note 1)	— — —	1000 300 300	ns	1.7V ≤ VCC ≤ 2.5V 2.5V ≤ VCC ≤ 5.5V 2.5V ≤ VCC ≤ 5.5V (Note 6) (24FC1025 only)
5	TF	SDA and SCL fall time (Note 1)	— —	300 100	ns	All except, 24FC1025 2.5V ≤ VCC ≤ 5.5V (Note 6) (24FC1025 only)
6	THD:STA	Start condition hold time	4000 600 250	— — —	ns	1.7V ≤ VCC ≤ 2.5V 2.5V ≤ VCC ≤ 5.5V 2.5V ≤ VCC ≤ 5.5V (Note 6) (24FC1025 only)
7	TSU:STA	Start condition setup time	4700 600 250	— — —	ns	1.7V ≤ VCC ≤ 2.5V 2.5V ≤ VCC ≤ 5.5V 2.5V ≤ VCC ≤ 5.5V (Note 6) (24FC1025 only)
8	THD:DAT	Data input hold time	0	—	ns	(Note 2)
9	TSU:DAT	Data input setup time	250 100 100	— — —	ns	1.7V ≤ VCC ≤ 2.5V 2.5V ≤ VCC ≤ 5.5V 2.5V ≤ VCC ≤ 5.5V (Note 6) (24FC1025 only)
10	TSU:STO	Stop condition setup time	4000 600 250	— — —	ns	1.7V ≤ VCC ≤ 2.5V 2.5V ≤ VCC ≤ 5.5V 2.5V ≤ VCC ≤ 5.5V (Note 6) (24FC1025 only)
11	TSU:WP	WP setup time	4000 600 600	— — —	ns	1.7V ≤ VCC ≤ 2.5V 2.5V ≤ VCC ≤ 5.5V 2.5V ≤ VCC ≤ 5.5V (Note 6) (24FC1025 only)
12	THD:WP	WP hold time	4700 1300 1300	— — —	ns	1.7V ≤ VCC ≤ 2.5V 2.5V ≤ VCC ≤ 5.5V 2.5V ≤ VCC ≤ 5.5V (Note 6) (24FC1025 only)
13	TAA	Output valid from clock (Note 2)	— — —	3500 900 400	ns	1.7V ≤ VCC ≤ 2.5V 2.5V ≤ VCC ≤ 5.5V 2.5V ≤ VCC ≤ 5.5V (Note 6) (24FC1025 only)
14	TBUF	Bus free time: Time the bus must be free before a new transmission can start	4700 1300 500	— — —	ns	1.7V ≤ VCC ≤ 2.5V 2.5V ≤ VCC ≤ 5.5V 2.5V ≤ VCC ≤ 5.5V (Note 6) (24FC1025 only)
15	TOF	Output fall time from VIH minimum to VIL maximum CB ≤ 100 pF	10 + 0.1CB	250 250	ns	All except, 24FC1025 (Note 1) 24FC1025 (Note 1)

Note 1: Not 100% tested. CB = total capacitance of one bus line in pF.

Note 2: As a transmitter, the device must provide an internal minimum delay time to bridge the undefined region (minimum 300 ns) of the falling edge of SCL to avoid unintended generation of Start or Stop conditions.

Note 3: The combined TSP and VHYS specifications are due to new Schmitt Trigger inputs which provide improved noise spike suppression. This eliminates the need for a TI specification for standard operation.

Note 4: This parameter is not tested but established by characterization. For endurance estimates in a specific application, please consult the Total Endurance™ Model which can be obtained from Microchip's web site

Note 5: Max. clock frequency is 100 kHz for E-temp devices <4.5V. 1.7-2.5V (100 kHz) timings must be used.

Note 6: Max. clock frequency is 400 kHz for 24FC1025, VCC < 2.5V.

24AA1025/24LC1025/24FC1025

AC CHARACTERISTICS (Continued)			Industrial (I): VCC = +1.7V to 5.5V TA = -40°C to +85°C Automotive (E): VCC = +2.5V to 5.5V TA = -40°C to +125°C			
Param. No.	Sym.	Characteristic	Min.	Max.	Units	Conditions
16	TSP	Input filter spike suppression (SDA and SCL pins)	—	50	ns	All except, 24FC1025 (Note 1 and Note 3)
17	TWC	Write cycle time (byte or page)	—	5	ms	3 ms, typical
18		Endurance	1 M	—	cycles	25°C (Note 4)

- Note 1:** Not 100% tested. CB = total capacitance of one bus line in pF.
- Note 2:** As a transmitter, the device must provide an internal minimum delay time to bridge the undefined region (minimum 300 ns) of the falling edge of SCL to avoid unintended generation of Start or Stop conditions.
- Note 3:** The combined TSP and VHYS specifications are due to new Schmitt Trigger inputs which provide improved noise spike suppression. This eliminates the need for a TI specification for standard operation.
- Note 4:** This parameter is not tested but established by characterization. For endurance estimates in a specific application, please consult the Total Endurance™ Model which can be obtained from Microchip's web site
- Note 5:** Max. clock frequency is 100 kHz for E-temp devices <4.5V. 1.7-2.5V (100 kHz) timings must be used.
- Note 6:** Max. clock frequency is 400 kHz for 24FC1025, Vcc < 2.5V.

FIGURE 1-1: BUS TIMING DATA

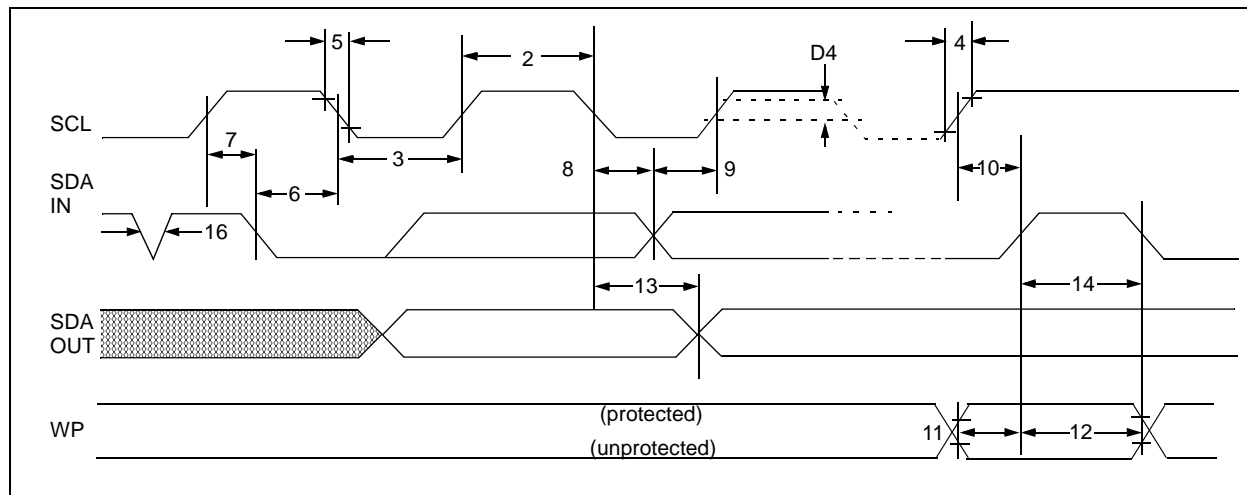

24AA1025/24LC1025/24FC1025

8-Lead Plastic Small Outline (SM) – Medium, 5.28 mm Body [SOIJ]

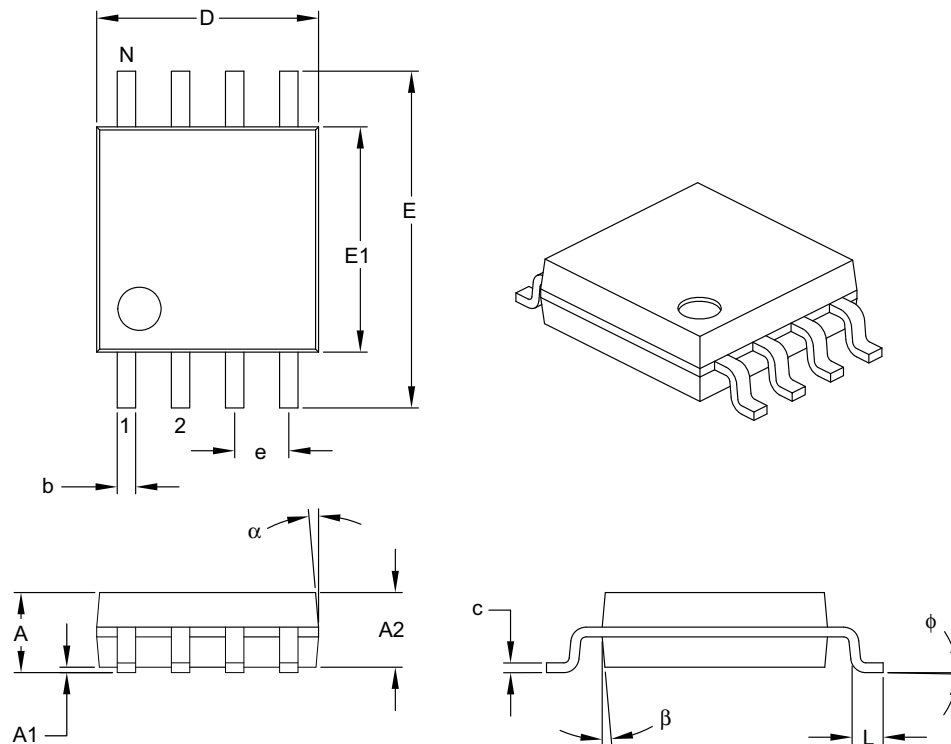

Dimension Limits	Units	MILLIMETERS		
		MIN	NOM	MAX
Number of Pins	N	8		
Pitch	e	1.27 BSC		
Overall Height	A	1.77	–	2.03
Molded Package Thickness	A2	1.75	–	1.98
Standoff §	A1	0.05	–	0.25
Overall Width	E	7.62	–	8.26
Molded Package Width	E1	5.11	–	5.38
Overall Length	D	5.13	–	5.33
Foot Length	L	0.51	–	0.76
Foot Angle	ϕ	0°	–	8°
Lead Thickness	c	0.15	–	0.25
Lead Width	b	0.36	–	0.51
Mold Draft Angle Top	α	–	–	15°
Mold Draft Angle Bottom	β	–	–	15°

Notes:

1. SOIJ, JEITA/EIAJ Standard, formerly called SOIC.
2. § Significant Characteristic.
3. Dimensions D and E1 do not include mold flash or protrusions. Mold flash or protrusions shall not exceed 0.25 mm per side.

Microchip Technology Drawing C04-056B

24AA1025/24LC1025/24FC1025

8-Lead Plastic Small Outline (SM) - Medium, 5.28 mm Body [SOIJ]

For more package drawings, please see the Microchip Packaging Specification located at [www.microchip.com/packaging](#)

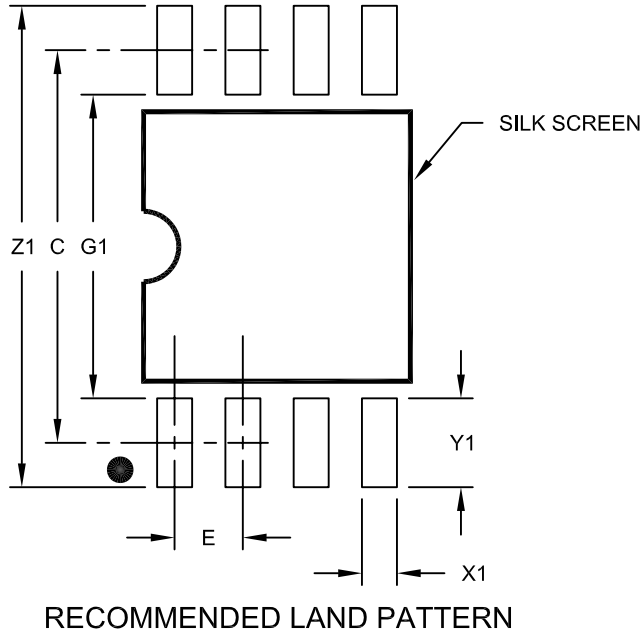

Dimension Limits	Units	MILLIMETERS		
		MIN	NOM	MAX
Contact Pitch	E	1.27 BSC		
Overall Width	Z1			9.00
Contact Pad Spacing	C1		7.30	
Contact Pad Width (X28)	X1			0.65
Contact Pad Length (X28)	Y1			1.70
Distance Between Pads	G1	5.60		
Distance Between Pads	G	0.62		

Notes:

1. Dimensioning and tolerancing per ASME Y14.5M

BSC: Basic Dimension. Theoretically exact value shown without tolerances.

Microchip Technology Drawing No. C04-2056B

24AA1025/24LC1025/24FC1025

PRODUCT IDENTIFICATION SYSTEM

To order or obtain information, e.g., on pricing or delivery, refer to the factory or the listed sales office.

<u>PART NO.</u>	<u>X</u>	<u>/XX</u>
Device	Temperature Range	Package
Device:		
24AA1025	=	1024K Bit 1.7V I ² C CMOS Serial EEPROM
24AA1025T	=	1024K Bit 1.7V I ² C CMOS Serial EEPROM (Tape and Reel)
24LC1025	=	1024K Bit 2.5V I ² C CMOS Serial EEPROM
24LC1025T	=	1024K Bit 2.5V I ² C CMOS Serial EEPROM (Tape and Reel)
24FC1025	=	1024K Bit 1.8V I ² C CMOS Serial EEPROM
24FC1025T	=	1024K Bit 1.8V I ² C CMOS Serial EEPROM (Tape and Reel)
Temperature Range:	I	= -40°C to +85°C
	E	= -40°C to +125°C
Package:	P	= Plastic DIP (300 mil Body), 8-lead
	SM	= Plastic SOIJ (5.28 mm Body), 8-lead

Examples:

- 24AA1025T-I/SM: Tape and Reel, Industrial Temperature, SOIJ package.
- 24LC1025-I/P: Industrial Temperature, PDIP package.
- 24LC1025-E/SM: Extended Temperature, SOIJ package.
- 24LC1025T-I/SM: Tape and Reel, Industrial Temperature, SOIJ package.