

AND791GST/GST-LED

4 Lines x 40 Characters

Intelligent Character Display

The AND791GST/GST-LED devices are compact, LCD modules that have an on-board LCD controller and driver circuit. These devices can display 160 characters (numerals, letters, symbols and Kana letters), as well as eight custom characters.

Features

- AND791GST: Super Twist Technology
- AND791GST-LED: STN with LED backlight
- Low voltage, +5V single power supply
- Controller on board (HD44780)
- Direct interface to 4- or 8-bit CPU
- 11 commands for control
- Wide temperature range option (WGST)

Dot Matrix Dimensions

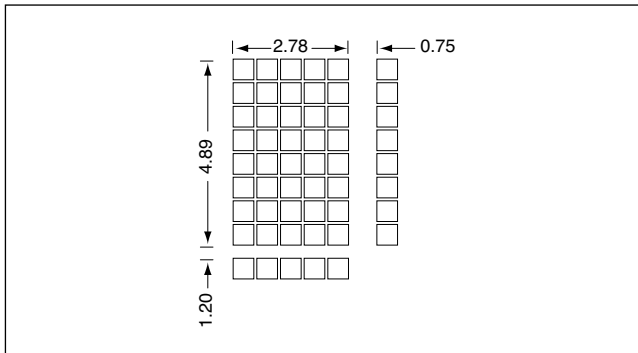

Mechanical Characteristics

Item	Specification	Unit
Outline Dimensions	190.0 (W) x 54.0 (H) x 10 (D)	mm
Character Size	2.78 (W) x 4.89 (H)	mm
Viewing Area	147.0 (W) x 29.5 (H)	mm
Dot Size	0.50 x 0.55	mm
Dot Pitch	0.57 x 0.62	mm

Absolute Maximum Ratings

Item	Symbol	Rating	Unit
Supply Voltage	V_{DD}	7.0	V
Input Voltage	V_{IN}	$0 \leq V_{IN} \leq V_{DD}$	V
LED Forward Current	I_F	960	mA
LED Reverse Voltage	V_R	8	V

Absolute Maximum Ratings (Continued)

Item	Symbol	Rating	Unit
LED Power Dissipation	P_D	4160	mW
Operating Temperature	T_{op}	0 to +50	°C
Storage Temperature	T_{stg}	-20 to +70	°C

Electrical Characteristics (TA = 25°C)

Item	Symbol	Min.	Typ.	Max.	Unit
Supply Voltage	V_{DD}	4.75	5.00	5.25	V
	$V_{DD}-V_O$	3.0	-	6.3	
High Level In Voltage	V_{IH1}	2.2	-	V_{DD}	V
Low Level In Voltage ($I_{OH} = 0.2$ mA)	V_{IL1}	0	-	0.6	V
High Level Output Volt. ($-I_{OH} = 0.2$ mA)	V_{OH1}	2.4	-	-	V
Low Level Output Volt. ($I_{OL} = 1.2$ mA)	V_{OL1}	-	-	0.4	V
LED Forward Voltage ($I_F = 480$ mA)	V_F	3.8	4.1	4.4	V
LED Reverse Current ($V_R = 8$ V)	I_R	-	-	4.8	mA

Optical Characteristics (TA = 25°C, $\phi = 0^\circ$, $\theta = 0^\circ$)

Item	Symbol	Min.	Typ.	Max.	Unit
Viewing Angle	ϕ	-	50	-	degree
Contrast	K	-	6.0	-	-
Response time (rise)	T_{on}	-	140	170	ms
Response time (fall)	T_{off}	-	160	190	ms

Product specifications contained herein may be changed without prior notice. It is therefore advisable to contact Purdy Electronics before proceeding with the design of equipment incorporating this product.



AND791GST/GST-LED Intelligent Character Display

Connector Pin Assignment

Pin No.	Signal	Function
1	DB ₇	Data bus line DB0-DB7 are for 8-bit operation DB4-DB7 are for 4-bit operation
2	DB ₆	
3	DB ₅	
4	DB ₄	
5	DB ₃	
6	DB ₂	
7	DB ₁	
8	DB ₀	
9	E ₁	Enable (for upper 2 lines)
10	R/W	L: Data write from MPU to LCM. H: Data read from LCM to MPU
11	RS	L: Instruction code input. H: Data input
12	V _O	Liquid crystal driving voltage
13	GND	Ground
14	V _{DD}	Power supply voltage + 5V
15	E ₂	Enable (for lower 2 lines)
16	NC	No Connect

Power Supply

LCD panel is driven by the voltage $V_{DD}-V_O$, so an adjustable V_O is required for contrast control and temperature compensation.

Temperature Variations

Temperature	$V_{DD}-V_O$
0°C	5.00
+25°C	4.75
+50°C	4.50

Power Supply Block Diagram

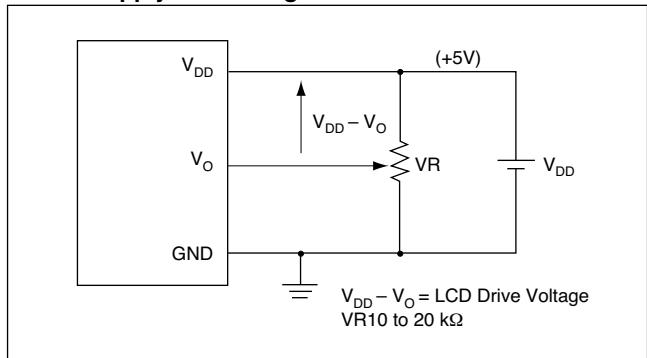

Dimensional Outline

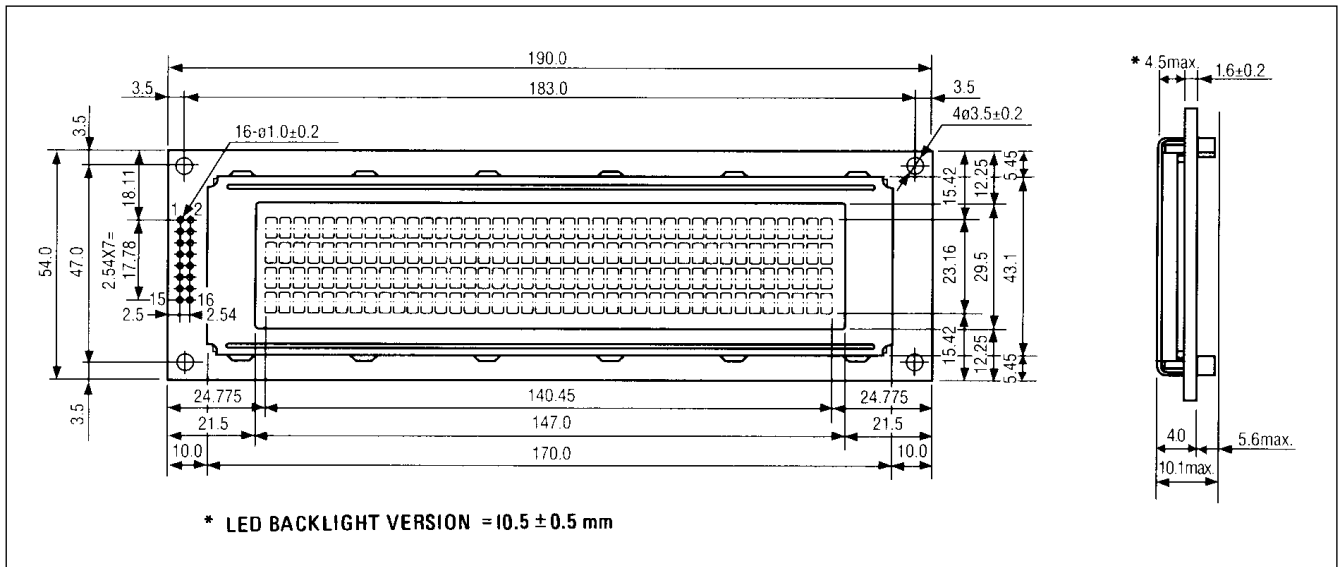



AND791GST/GST-LED Intelligent Character Display
