

EchoPod®

DL10 Ultrasonic Level Transmitter

Introducing EchoPod

The general purpose, DL10 ultrasonic sensor provides non-contact level measurement up to 49.2" (1.25m) with a 4-20 mA output. The DL10 directly replaces contact measurement sensors connected to a PLC analog input card for easy design conversion or field retrofit. The two-wire, 4-20 mA output is ideal for longer signal distances up to 1000'. The sensor is well suited for a wide range of corrosive, sticky or dirty type media. The DL10 is broadly selected for small atmospheric tank, IBC, drum, skid or process vessel and sump applications. To configure EchoPod, download our free WebCal software and purchase one USB interface tool.

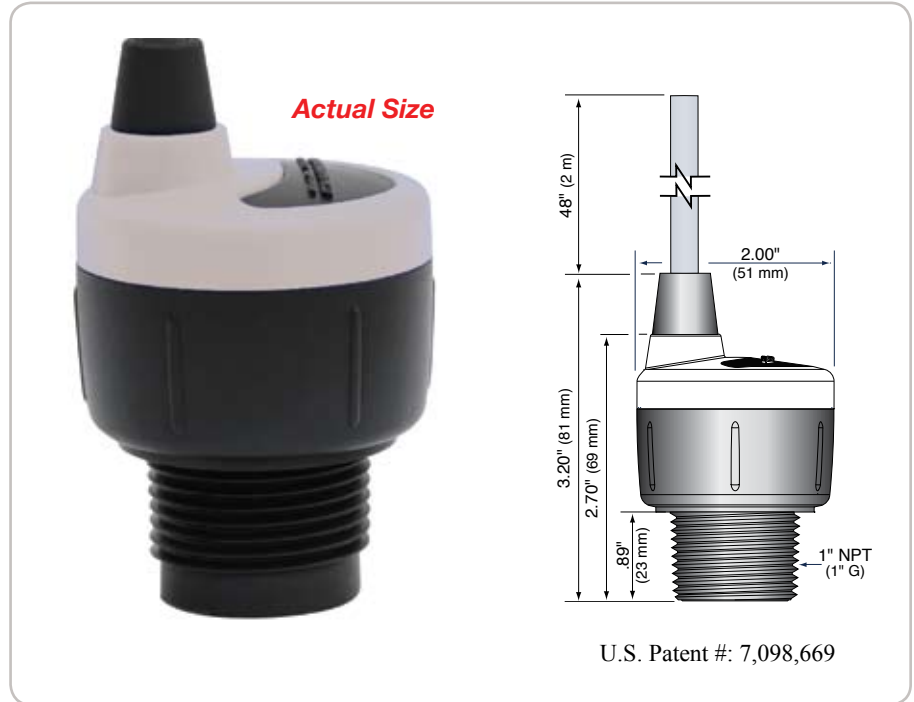

Specifications

Range:	49.2" (1.25 m)
Accuracy:	0.125" (3 mm)
Resolution:	0.019" (0.5 mm)
Beam width:	2" (5 cm)
Dead band:	2" (5 cm)
Supply voltage:	24 VDC (loop)
Loop resistance:	400Ω max @ 24 VDC
Consumption:	0.5W
Signal output:	4-20 mA, two-wire reversible mA
Loop fail-safety:	4 mA, 20 mA, 21 mA, 22 mA, hold last
Configuration:	WebCal® USB 2.0
Temp. comp.:	Automatic over range
Process temp.:	F: -20° to 140° C: -7° to 60°
Ambient temp.:	F: -31° to 140° C: -35° to 60°
Pressure:	MWP = 30 PSI
Enclosure:	Type 6P encapsulated, corrosion resistant & submersible
Encl. material:	Polycarbonate
Strain relief mat.:	Santoprene
Trans. material:	PVDF
Cable length:	48" (1.2 m)
Cable jacket mat.:	Polyurethane
Process mount:	1" NPT (1" G)
Mount. gasket:	Viton®
Classification:	General purpose
Approvals:	CE, cFMus

Features

- Transmitter provides 4-20 mA level measurement
- Compact sensor with 2" beam width and 2" dead band optimized for small tank applications
- Rugged PVDF transducer and polycarbonate enclosure rated 6P for corrosive media

Configuration

EchoPod is configured using Flowline's WebCal software and Fob, a USB® interface tool. A single configuration can be easily created, saved, duplicated, emailed or modified. Take control of your level process with WebCal's intuitive interface, pre-programmed menus, tank set point graphics and custom wiring diagrams for each of your configurations. It's level configuration made simple.



EchoPod®

Ordering

DL10-	<input type="checkbox"/>	<input type="checkbox"/>
Process mount (1)		
0	NPT (US)	
1	G (Metric)	
Fob USB interface (2)		
0	Without Fob	
1	With Fob	

Ordering Notes

- 1) EchoPod can not be configured without the Fob USB interface tool (LI99-1001) and WebCal. One Fob will configure all EchoPods.
- 2) WebCal is a free download from our website at www.flowline.com (Windows® XP Compatible, USB 2.0).