



Maxim > Products > [Timekeeping, Timers, and Counters] [Military/Aerospace]

MAX8211, MAX8212

Microprocessor Voltage Monitors with Programmable Voltage Detection

Description

Maxim's MAX8211 and MAX8212 are CMOS micropower voltage detectors that warn microprocessors (μ Ps) of power failures. Each contains a comparator, a 1.5V bandgap reference, and an open-drain n-channel output driver. Two external resistors are used in conjunction with the internal reference to set the trip voltage to the desired level. A hysteresis output is also included, allowing the user to apply positive feedback for noise-free output switching.

The MAX8211 provides a 7mA current-limited output sink whenever the voltage applied to the threshold pin is less than the 1.5V internal reference. In the MAX8212, a voltage greater than 1.5V at the threshold pin turns the output stage on (no current limit).

The CMOS MAX8211/MAX8212 are plug-in replacements for the bipolar ICL8211/ICL8212 in applications where the maximum supply voltage is less than 16.5V. They offer several performance advantages, including reduced supply current, a more tightly controlled bandgap reference, and more available current from the hysteresis output.

Key Features

- μ P Power-Fail Warning
- Improved 2nd Source for ICL8211/ICL8212
- Low-Power CMOS Design
- 5 μ A Quiescent Current
- On-Board Hysteresis Output
- ± 40 mV Threshold Accuracy ($\pm 3.5\%$)
- 2.0V to 16.5V Supply-Voltage Range
- Define Output Current Limit (MAX8211)
- High Output Current Capability (MAX8212)

Applications/Uses

μ P Voltage Monitoring
Battery-Backup Switching
Low-Battery Detection
Overvoltage Detection
Power-Supply Fault Monitoring
Undervoltage Detection

Key Specifications: Supervisors (1 Monitored Voltage)

Part Number	Reset Threshold Range (V)	Active-Low Reset Output	Min. Reset Timeout Range	Watchdog Feature	Supervisor Features	Reset Thresh. Acc. (% @+25°C)	Max. I _{CC} (μA)
MAX8211	1.2 to 1.8 1.8 to 2.5	Open Drain	<1ms	No Watchdog	High Voltage (>6V)	3	15
MAX8212	2.5 to 3.3 3.3 to 5.5						

[See All Supervisors \(1 Monitored Voltage\) \(268\)](#)

Notes:

**This pricing is BUDGETARY, for comparing similar parts. Prices are in U.S. dollars and subject to change. Quantity pricing may vary substantially and international prices may differ due to local duties, taxes, fees, and exchange rates. For volume-specific prices and delivery, please see the [price and availability](#) page or contact an authorized distributor.

Diagram

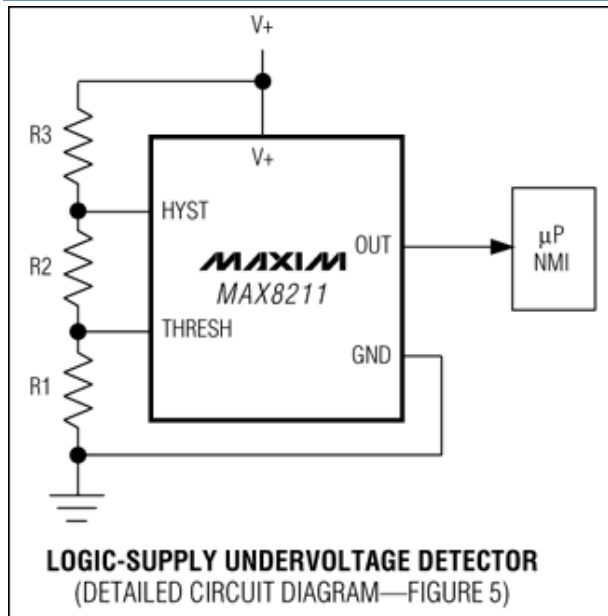

Typical Operating Circuit

Application Notes

Application Note 926: Simple Circuit Disconnects Load From Battery - MAX8212
 Application Note 968: Load-Disconnect Switch Consumes Only 8µA - MAX8211
 Application Note 2018: Protection From Blackouts: Dirt Cheap to Fully Integrated - MAX8211

Evaluation Kits

none

Design Guides

Real-Time Clocks (PDF)

Reliability Reports

Show FIT data for:
 Reliability Report: [MAX8211xxx.pdf](#) [MAX8212xxx.pdf](#)

Software/Models

none

Ordering Information

Notes:

1. Other options and links for purchasing parts are listed at:
2. [Didn't Find What You Need?](#) Ask our applications engineers. Expert assistance in finding parts, usually within one business day.
3. Part number suffixes: T or T&R = tape and reel; + = RoHS/lead-free; # = RoHS/lead-exempt. More: See [Full Data Sheet](#) or [Part Naming Conventions](#).
4. * Some packages have variations, listed on the drawing. "PkgCode/Variation" tells which variation the product uses. Note that "+", "#", "-" in the part number suffix describes RoHS status. Package drawings may show a different suffix character.

Devices: 1-55 of 55

MAX8211	Free Sample	Buy	Package: TYPE PINS FOOTPRINT DRAWING CODE/VAR *	Temp	RoHS/Lead-Free? Materials Analysis
MAX8211EJA			Ceramic DIP; 8 pin; Dwg: 21-0045 (PDF) Use pkgcode/variation: J8-2*	-40°C to +85°C	RoHS/Lead-Free: No Materials Analysis

MAX8211MJA/HR			Ceramic DIP; 8 pin; Dwg: 21-0045 (PDF) Use pkgcode/variation: J8-2*	-55°C to +125°C	RoHS/Lead-Free: No Materials Analysis
MAX8211MJA/883B			Ceramic DIP; 8 pin; Dwg: 21-0045 (PDF) Use pkgcode/variation: J8-2*	-55°C to +125°C	RoHS/Lead-Free: No Materials Analysis
MAX8211MJA			Ceramic DIP; 8 pin; Dwg: 21-0045 (PDF) Use pkgcode/variation: J8-2*	-55°C to +125°C	RoHS/Lead-Free: No Materials Analysis
MAX8211C/D					See data sheet
MAX8211MFB/883B			FPCK; 10 pin; Dwg: 21-0010 (PDF) Use pkgcode/variation: F10-3*	-55°C to +125°C	See data sheet
MAX8211MTV/HR			Gold Can -TO; 8 pin; Dwg: 21-0022 (PDF) Use pkgcode/variation: G99-8*	-55°C to +125°C	RoHS/Lead-Free: No Materials Analysis
MAX8211MTV/883B			Gold Can -TO; 8 pin; Dwg: 21-0022 (PDF) Use pkgcode/variation: G99-8*	-55°C to +125°C	RoHS/Lead-Free: No Materials Analysis
MAX8211CTY			Metal Can-TO; 8 pin; Dwg: 21-0022 (PDF) Use pkgcode/variation: T99-8*	0°C to +70°C	RoHS/Lead-Free: No Materials Analysis
MAX8211CTY-2			Metal Can-TO; 8 pin; Dwg: 21-0022 (PDF) Use pkgcode/variation: T99-8*	0°C to +70°C	RoHS/Lead-Free: No Materials Analysis
MAX8211ETY			Metal Can-TO; 8 pin; Dwg: 21-0022 (PDF) Use pkgcode/variation: T99-8*	-40°C to +85°C	RoHS/Lead-Free: No Materials Analysis
MAX8211MTY			Metal Can-TO; 8 pin; Dwg: 21-0022 (PDF) Use pkgcode/variation: T99-8*	-55°C to +125°C	RoHS/Lead-Free: No Materials Analysis
MAX8211CPA+			PDIP; 8 pin; Dwg: 21-0043 (PDF) Use pkgcode/variation: P8+1*	0°C to +70°C	RoHS/Lead-Free: Lead Free Materials Analysis
MAX8211CPA			PDIP; 8 pin; Dwg: 21-0043 (PDF) Use pkgcode/variation: P8-1*	0°C to +70°C	RoHS/Lead-Free: No Materials Analysis
MAX8211EPA+			PDIP; 8 pin; Dwg: 21-0043 (PDF) Use pkgcode/variation: P8+1*	-40°C to +85°C	RoHS/Lead-Free: Lead Free Materials Analysis

MAX8211EPA			PDIP; 8 pin; Dwg: 21-0043 (PDF) Use pkgcode/variation: P8-1*	-40°C to +85°C	RoHS/Lead-Free: No Materials Analysis
MAX8211IPA			PDIP; 8 pin; Dwg: 21-0043 (PDF) Use pkgcode/variation: P8-1*	-20°C to +85°C	RoHS/Lead-Free: No Materials Analysis
MAX8211CSA+T			SOIC; 8 pin; Dwg: 21-0041 (PDF) Use pkgcode/variation: S8+2*	0°C to +70°C	RoHS/Lead-Free: Lead Free Materials Analysis
MAX8211CSA			SOIC; 8 pin; Dwg: 21-0041 (PDF) Use pkgcode/variation: S8-2*	0°C to +70°C	RoHS/Lead-Free: No Materials Analysis
MAX8211CSA-T			SOIC; 8 pin; Dwg: 21-0041 (PDF) Use pkgcode/variation: S8-2*	0°C to +70°C	RoHS/Lead-Free: No Materials Analysis
MAX8211CSA+			SOIC; 8 pin; Dwg: 21-0041 (PDF) Use pkgcode/variation: S8+2*	0°C to +70°C	RoHS/Lead-Free: Lead Free Materials Analysis
MAX8211ESA-T			SOIC; 8 pin; Dwg: 21-0041 (PDF) Use pkgcode/variation: S8-2*	-40°C to +85°C	RoHS/Lead-Free: No Materials Analysis
MAX8211ESA			SOIC; 8 pin; Dwg: 21-0041 (PDF) Use pkgcode/variation: S8-2*	-40°C to +85°C	RoHS/Lead-Free: No Materials Analysis
MAX8211ESA+			SOIC; 8 pin; Dwg: 21-0041 (PDF) Use pkgcode/variation: S8+2*	-40°C to +85°C	RoHS/Lead-Free: Lead Free Materials Analysis
MAX8211ESA+T			SOIC; 8 pin; Dwg: 21-0041 (PDF) Use pkgcode/variation: S8+2*	-40°C to +85°C	RoHS/Lead-Free: Lead Free Materials Analysis
MAX8211CUA+T			uMAX; 8 pin; Dwg: 21-0036 (PDF) Use pkgcode/variation: U8+1*	0°C to +70°C	RoHS/Lead-Free: Lead Free Materials Analysis
MAX8211CUA+			uMAX; 8 pin; Dwg: 21-0036 (PDF) Use pkgcode/variation: U8+1*	0°C to +70°C	RoHS/Lead-Free: Lead Free Materials Analysis
MAX8211CUA			uMAX; 8 pin; Dwg: 21-0036 (PDF) Use pkgcode/variation: U8-1*	0°C to +70°C	RoHS/Lead-Free: No Materials Analysis
MAX8211CUA-T			uMAX; 8 pin; Dwg: 21-0036 (PDF) Use pkgcode/variation: U8-1*	0°C to +70°C	RoHS/Lead-Free: No Materials Analysis

Notes and Comments

Single channel: noninverting
(MAX8211)
Single channel: inverting (MAX8212)

More Information

New Product Press Release [2008-11-25](#)

Related Products

[ICL7665](#) μ P Voltage Monitor with Dual Over/Undervoltage Detection
[MAX836](#), [MAX837](#) 4-Pin Micropower Voltage Monitors
[MAX834](#), [MAX835](#) Micropower, Latching Voltage Monitors in SOT23-5
[MAX8215](#), [MAX8216](#) $\pm 5V$, $\pm 12V$ ($\pm 15V$) Dedicated Microprocessor Voltage Monitors
[MAX8213](#), [MAX8214](#) Five Universal Voltage Monitors, Complete μ P Voltage Monitoring
[MAX6806](#), [MAX6807](#), [MAX6808](#) Voltage Detectors



Microprocessor Voltage Monitors with Programmable Voltage Detection

MAX8211/MAX8212

General Description

Maxim's MAX8211 and MAX8212 are CMOS micropower voltage detectors that warn microprocessors (μ Ps) of power failures. Each contains a comparator, a 1.5V bandgap reference, and an open-drain n-channel output driver. Two external resistors are used in conjunction with the internal reference to set the trip voltage to the desired level. A hysteresis output is also included, allowing the user to apply positive feedback for noise-free output switching.

The MAX8211 provides a 7mA current-limited output sink whenever the voltage applied to the threshold pin is less than the 1.5V internal reference. In the MAX8212, a voltage greater than 1.5V at the threshold pin turns the output stage on (no current limit).

The CMOS MAX8211/MAX8212 are plug-in replacements for the bipolar ICL8211/ICL8212 in applications where the maximum supply voltage is less than 16.5V. They offer several performance advantages, including reduced supply current, a more tightly controlled bandgap reference, and more available current from the hysteresis output.

Applications

- μ P Voltage Monitoring
- Undervoltage Detection
- Overvoltage Detection
- Battery-Backup Switching
- Power-Supply Fault Monitoring
- Low-Battery Detection

Pin Configurations

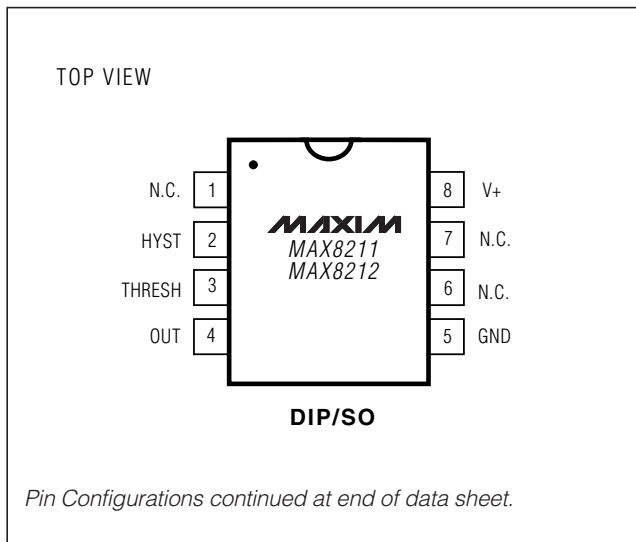

Features

- ◆ μ P Power-Fail Warning
- ◆ Improved 2nd Source for ICL8211/ICL8212
- ◆ Low-Power CMOS Design
- ◆ 5 μ A Quiescent Current
- ◆ On-Board Hysteresis Output
- ◆ ± 40 mV Threshold Accuracy ($\pm 3.5\%$)
- ◆ 2.0V to 16.5V Supply-Voltage Range
- ◆ Define Output Current Limit (MAX8211)
- ◆ High Output Current Capability (MAX8212)

Ordering Information

PART	TEMP RANGE	PIN-PACKAGE
MAX8211CPA	-0°C to +70°C	8 Plastic DIP
MAX8211CSA	-0°C to +70°C	8 SO
MAX8211CUA	-0°C to +70°C	8 μ MAX
MAX8211CTY	-0°C to +70°C	8 TO-99
MAX8211EPA	-40°C to +85°C	8 Plastic DIP
MAX8211ESA	-40°C to +85°C	8 SO
MAX8211EJA	-40°C to +85°C	8 CERDIP
MAX8211ETY	-40°C to +85°C	8 TO-99
MAX8211MJA	-55°C to +125°C	8 CERDIP**

Ordering Information continued on last page.

*Contact factory for dice specifications.

**Contact factory for availability and processing to MIL-STD-883.

Typical Operating Circuit

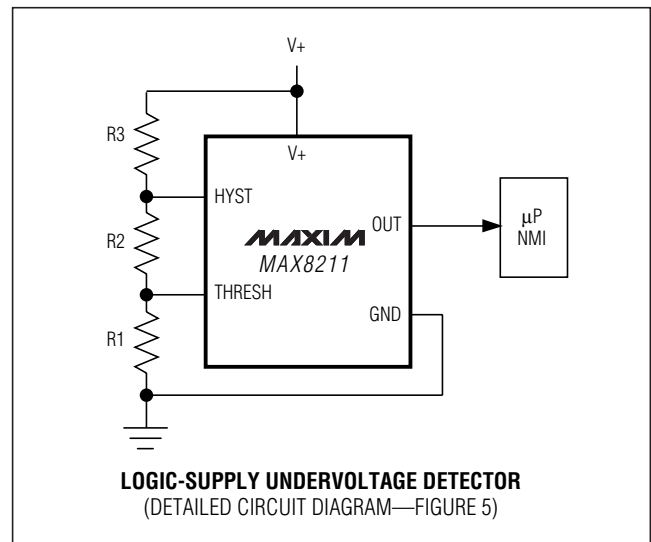

Microprocessor Voltage Monitors with Programmable Voltage Detection

ABSOLUTE MAXIMUM RATINGS

Supply Voltage	-0.5V to +18V	8-Pin CERDIP (derate 8.00mW/°C above +70°C)	640mW
Output Voltage	-0.5V to +18V	8-Pin TO-99 (derate 6.67mW/°C above +70°C)	533mW
Hysteresis	+0.5V to -18V with respect to (V+ + 0.5V)	Operating Temperature Ranges	
Threshold Input Voltage	-0.5V to (V+ + 0.5V)	MAX821_C_	0°C to +70°C
Current into Any Terminal	±50mA	MAX821_E_	-40°C to +85°C
Continuous Power Dissipation (T _A = +70°C)		MAX821_M_	-55°C to +125°C
8-Pin Plastic DIP (derate 9.09mW/°C above +70°C)	727mW	Storage Temperature Range	-65°C to +150°C
8-Pin SO (derate 5.88mW/°C above +70°C)	471mW	Lead Temperature (soldering, 10s)	+300°C

Stresses beyond those listed under "Absolute Maximum Ratings" may cause permanent damage to the device. These are stress ratings only, and functional operation of the device at these or any other conditions beyond those indicated in the operational sections of the specifications is not implied. Exposure to absolute maximum rating conditions for extended periods may affect device reliability.

ELECTRICAL CHARACTERISTICS

(V+ = 5V, T_A = +25°C, unless otherwise noted.)

PARAMETER	SYMBOL	CONDITIONS		MAX8211			MAX8212			UNITS
				MIN	TYP	MAX	MIN	TYP	MAX	
Supply Current	I ₊	2V ≤ V+ ≤ 16.5V, GND ≤ V _{TH} ≤ V+	T _A = +25°C	5	15		5	15	μA	
			T _A = T _{MIN} to T _{MAX}		20		20			
Threshold Trip Voltage	V _{TH}	T _A = +25°C	V+ = 16.5V, I _{OUT} = 4mA	1.11	1.19	1.11	1.19	V		
			V+ = 2V, I _{OUT} = 500μA							
		T _A = T _{MIN} to T _{MAX}	V+ = 16.5V, I _{OUT} = 3mA	1.05	1.25	1.05	1.25			
			V+ = 2.2V, I _{OUT} = 500μA							
Threshold Voltage Disparity between Output and Hysteresis Output	V _{THP}	I _{OUT} = 4mA, I _{HYST} = 1mA		±0.1		±0.1	mV			
Guaranteed Operating Supply Voltage Range	V _{SUPP}	T _A = +25°C		2.0	16.5	2.0	16.5	V		
		T _A = T _{MIN} to T _{MAX}		2.2	16.5	2.2	16.5			
Typical Operating Supply Voltage Range	V _{SUPP}			1.5	16.5	1.5	16.5	V		
Threshold Voltage Temperature Coefficient	ΔV _{TH} /ΔT	See Figure 4		-200		-200		ppm/°C		
Variation of Threshold Voltage with Supply Voltage	ΔV _{TH}	V+ = 4.5V to 5.5V		1.0		0.2		mV		
Threshold Input Current	I _{TH}	0V ≤ V _{TH} ≤ V+, T _A = +25°C		0.01	10	0.01	10	nA		
		T _A = T _{MIN} to T _{MAX}			20		20			
Output Leakage Current	I _{LOUT}	T _A = T _{MIN} to T _{MAX} , C/E temp. ranges	V _{OUT} = 16.5V, V _{TH} = 1.0V				10	μA		
			V _{OUT} = 16.5V, V _{TH} = 1.3V		10					
			V _{OUT} = 5V, V _{TH} = 1.0V				1			
			V _{OUT} = 5V, V _{TH} = 1.3V		1					
		T _A = T _{MIN} to T _{MAX} , M temp. range	V _{OUT} = 16.5V, V _{TH} = 0.9V				30			
			V _{OUT} = 16.5V, V _{TH} = 1.3V		30					
			V _{OUT} = 5V, V _{TH} = 0.9V				10			
			V _{OUT} = 5V, V _{TH} = 1.3V		10					

Microprocessor Voltage Monitors with Programmable Voltage Detection

MAX8211/MAX8212

ELECTRICAL CHARACTERISTICS (continued)

(V+ = 5V, T_A = +25°C, unless otherwise noted.)

PARAMETER	SYMBOL	CONDITIONS	MAX8211			MAX8212			UNITS
			MIN	TYP	MAX	MIN	TYP	MAX	
Output Saturation Voltage	V _{OL}	I _{OUT} = 2mA, V _{TH} = 1.0V	0.17	0.4				V	
		I _{OUT} = 2mA, V _{TH} = 1.3V				0.17	0.4		
Maximum Available Output Current	I _{OH}	C temp. range, V _{OUT} = 5V	V _{TH} = 1.0V (Note 1)	4	7.0			mA	
			V _{TH} = 1.3V (Note 2)			12	35		
Hysteresis Leakage Current	I _{LHYS}	T _A = T _{MIN} to T _{MAX} , C/E temp. ranges, V+ = 16.5V, V _{TH} = 1.0V, V _{HYST} = -16.5V with respect to V+			0.1		0.1	μA	
		T _A = T _{MIN} to T _{MAX} , M temp. range, V+ = 16.5V, V _{TH} = 0.9V, V _{HYST} = -16.5V with respect to V+			3		3		
Hysteresis Saturation Voltage	V _{HYS} (MAX)	I _{HYST} = 0.5mA, V _{TH} = 1.3V, measured with respect to V+	-0.1	-0.2		-0.1	-0.2	V	
Maximum Available Hysteresis Current	V _{HYS} (MAX)	V _{TH} = 1.3V, V _{HYS} = 0V	2	10		2	10	mA	

Note 1: The maximum output current of the MAX8211 is limited by design to 30mA under any operating condition. The output voltage may be sustained at any voltage up to +16.5V as long as the maximum power dissipation of the device is not exceeded.

Note 2: The maximum output current of the MAX8212 is not defined, and systems using the MAX8212 must therefore ensure that the output current does not exceed 50mA and that the maximum power dissipation of the device is not exceeded.

Detailed Description

As shown in the block diagrams of Figures 1 and 2, the MAX8211 and MAX8212 each contain a 1.15V reference, a comparator, an open-drain n-channel output transistor, and an open-drain p-channel hysteresis output. The MAX8211 output n-channel turns on when the voltage applied to the THRESH pin is less than the internal reference (1.15V). The sink current is limited to 7mA (typical), allowing direct drive of an LED without a series resistor. The MAX8212 output turns on when the voltage applied to THRESH is greater than the internal reference. It is not current limited, and will typically sink 35mA.

Compatibility with ICL8211/ICL8212

The CMOS MAX8211/MAX8212 are plug-in replacements for the bipolar ICL8211/ICL8212 in most applications. The use of CMOS technology has several advantages. The quiescent supply current is much less than in the bipolar parts. Higher-value resistors can also be used

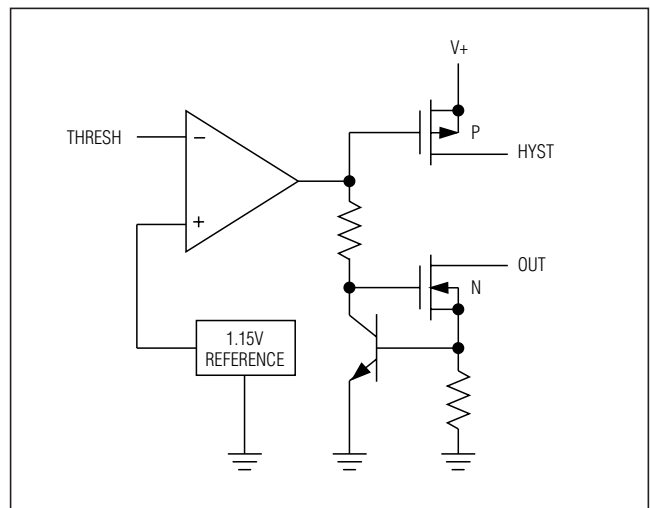
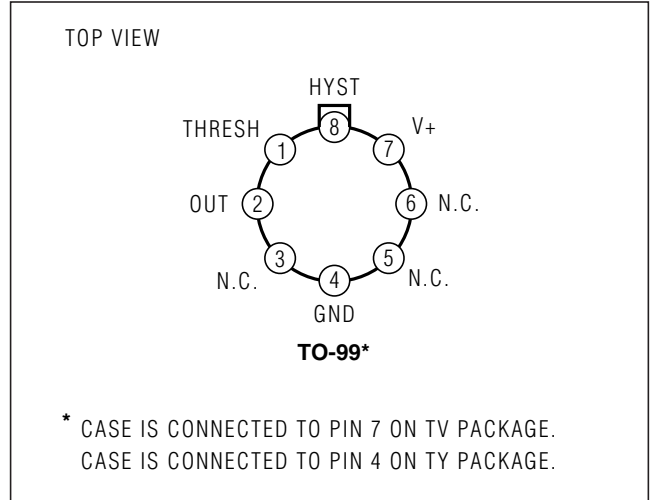
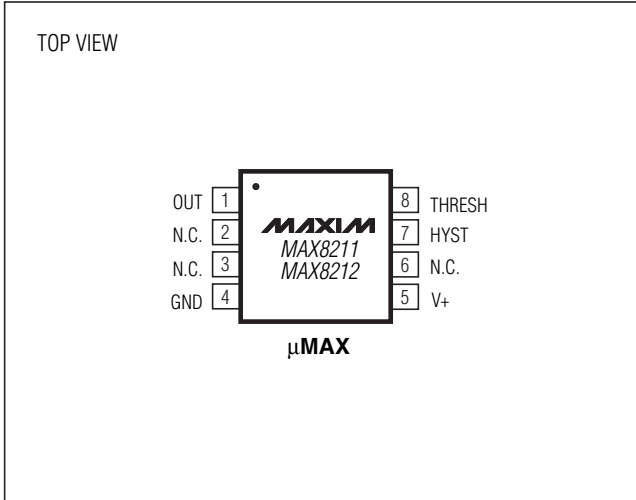

Figure 1. MAX8211 Block Diagram

Microprocessor Voltage Monitors with Programmable Voltage Detection

Pin Configurations (continued)



Ordering Information (continued)

PART	TEMP RANGE	PIN-PACKAGE
MAX8211MSA/PR	-55°C to +125°C	8 SO**
MAX8211MSA/PR-T	-55°C to +125°C	8 SO**
MAX8211MTV	-55°C to +125°C	8 TO-99**
MAX8212CPA	-0°C to +70°C	8 Plastic DIP
MAX8212CSA	-0°C to +70°C	8 SO
MAX8212CUA	-0°C to +70°C	8 μMAX
MAX8212CTY	-0°C to +70°C	8 TO-99
MAX8212EPA	-40°C to +85°C	8 Plastic DIP
MAX8212ESA	-40°C to +85°C	8 SO
MAX8212EJA	-40°C to +85°C	8 CERDIP
MAX8212ETY	-40°C to +85°C	8 TO-99
MAX8212MJA	-55°C to +125°C	8 CERDIP**
MAX8212MSA/PR	-55°C to +125°C	8 SO**
MAX8212MSA/PR-T	-55°C to +125°C	8 SO**
MAX8212MTV	-55°C to +125°C	8 TO-99**

*Contact factory for dice specifications.

**Contact factory for availability and processing to MIL-STD-883.

Package Information

PACKAGE TYPE	PACKAGE CODE	DOCUMENT NO.
8 CERDIP	J8-2	21-0045
8 Plastic DIP	P8-1	21-0043
8 SO	S8-2	21-0041
8 TO-99	T99-8	21-0022
8 μMAX	U8-1	21-0036

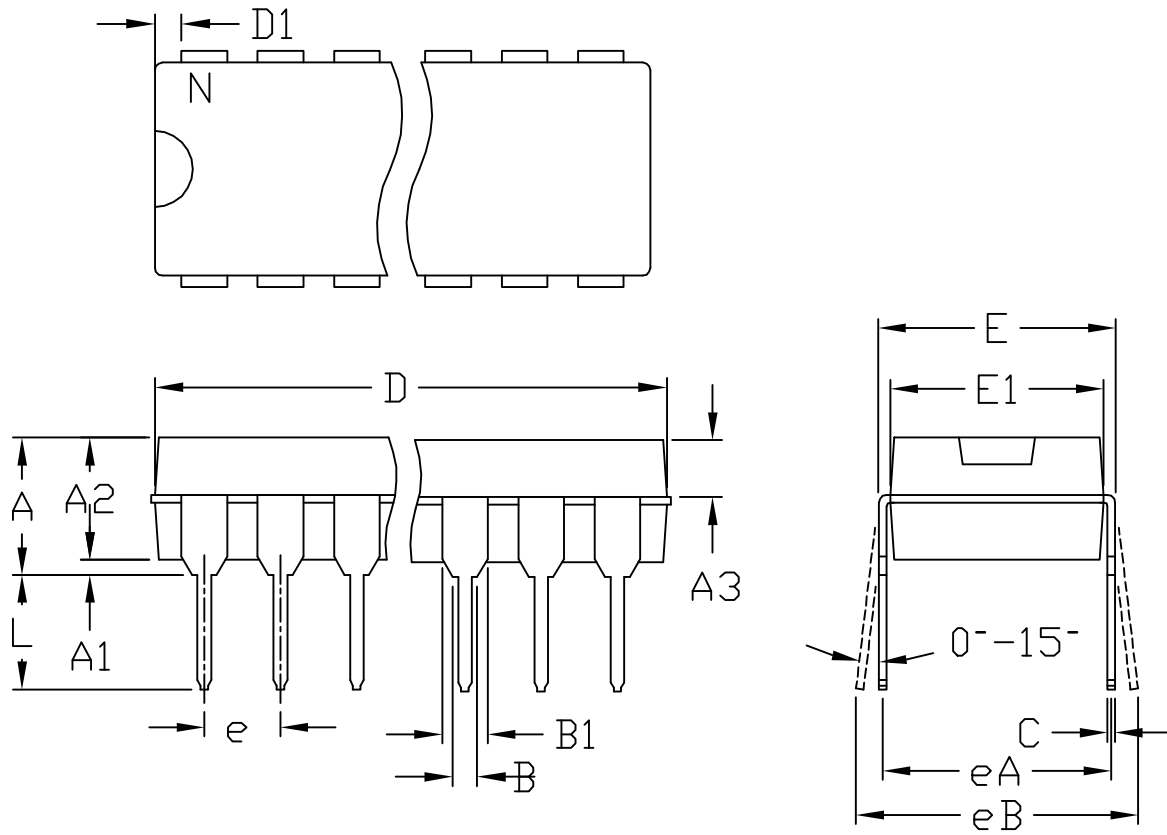

	INCHES		MILLIMETERS	
	MIN	MAX	MIN	MAX
A	---	0.180	---	4.572
A1	0.015	---	0.38	---
A2	0.125	0.175	3.18	4.45
A3	0.055	0.080	1.40	2.03
B	0.015	0.022	0.381	0.56
B1	0.045	0.065	1.14	1.65
C	0.008	0.014	0.2	0.355
D1	0.005	0.080	0.13	2.03
E	0.300	0.325	7.62	8.26
E1	0.240	0.310	6.10	7.87
e	0.100	BSC.	2.54	BSC.
eA	0.300	BSC.	7.62	BSC.
eB	0.400	BSC.	10.16	BSC.
L	0.115	0.150	2.921	3.81

	INCHES		MILLIMETERS		N	MS001
	MIN	MAX	MIN	MAX		
D	0.348	0.390	8.84	9.91	8	AB
D	0.735	0.765	18.67	19.43	14	AC
D	0.745	0.765	18.92	19.43	16	AA
D	0.885	0.915	22.48	23.24	18	AD
D	1.015	1.045	25.78	26.54	20	AE
D	1.14	1.265	28.96	32.13	24	AF
D	1.360	1.380	34.54	35.05	28	*5

- NOTES:
1. D&E DO NOT INCLUDE MOLD FLASH
 2. MOLD FLASH OR PROTRUSIONS NOT TO EXCEED .15mm (.006")
 3. CONTROLLING DIMENSION: MILLIMETER
 4. MEETS JEDEC MS001-XX AS SHOWN IN ABOVE TABLE
 5. SIMILIAR TO JEDEC MO-058AB
 6. N = NUMBER OF PINS



PACKAGE FAMILY OUTLINE: PDIP .300" TITLE

1/1

21-0043 D DOCUMENT CONTROL NUMBER REV

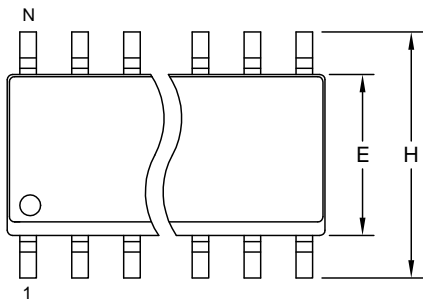

TOP VIEW

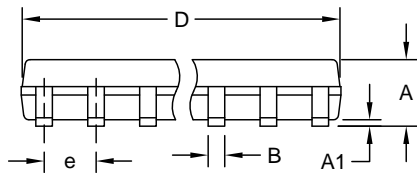

FRONT VIEW

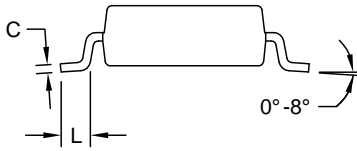

SIDE VIEW

DIM	INCHES		MILLIMETERS	
	MIN	MAX	MIN	MAX
A	0.053	0.069	1.35	1.75
A1	0.004	0.010	0.10	0.25
B	0.014	0.019	0.35	0.49
C	0.007	0.010	0.19	0.25
e	0.050 BSC		1.27 BSC	
E	0.150	0.157	3.80	4.00
H	0.228	0.244	5.80	6.20
L	0.016	0.050	0.40	1.27

VARIATIONS:

DIM	INCHES		MILLIMETERS		N	MS012
	MIN	MAX	MIN	MAX		
D	0.189	0.197	4.80	5.00	8	AA
D	0.337	0.344	8.55	8.75	14	AB
D	0.386	0.394	9.80	10.00	16	AC

NOTES:

1. D&E DO NOT INCLUDE MOLD FLASH.
2. MOLD FLASH OR PROTRUSIONS NOT TO EXCEED 0.15mm (.006").
3. LEADS TO BE COPLANAR WITHIN 0.10mm (.004").
4. CONTROLLING DIMENSION: MILLIMETERS.
5. MEETS JEDEC MS012.
6. N = NUMBER OF PINS.

<small>PROPRIETARY INFORMATION</small>	
<small>TITLE:</small> PACKAGE OUTLINE, .150" SOIC	
<small>APPROVAL</small>	<small>DOCUMENT CONTROL NO.</small> 21-0041
<small>REV.</small> B	<small>1/1</small>