



93AA86A/B/C, 93LC86A/B/C, 93C86A/B/C

16K Microwire Compatible Serial EEPROM

Device Selection Table

Part Number	Vcc Range	ORG Pin	PE Pin	Word Size	Temp Ranges	Packages
93AA86A	1.8-5.5	No	No	8-bit	I	OT, SN
93AA86B	1.8-5.5	No	No	16-bit	I	OT, SN
93LC86A	2.5-5.5	No	No	8-bit	I, E	OT, SN
93LC86B	2.5-5.5	No	No	16-bit	I, E	OT, SN
93C86A	4.5-5.5	No	No	8-bit	I, E	OT, SN
93C86B	4.5-5.5	No	No	16-bit	I, E	OT, SN
93AA86C	1.8-5.5	Yes	Yes	8- or 16-bit	I	P, SN, ST, MS, MC
93LC86C	2.5-5.5	Yes	Yes	8- or 16-bit	I, E	P, SN, ST, MS, MC
93C86C	4.5-5.5	Yes	Yes	8- or 16-bit	I, E	P, SN, ST, MS, MC

Features:

- Low-Power CMOS Technology
- ORG Pin to Select Word Size for '86C' Version
- 2048 x 8-bit Organization 'A' Devices (no ORG)
- 1024 x 16-bit Organization 'B' Devices (no ORG)
- Program Enable Pin to Write-Protect the Entire Array ('86C' version only)
- Self-timed Erase/Write Cycles (including Auto-Erase)
- Automatic Erase All (ERAL) Before Write All (WRAL)
- Power-On/Off Data Protection Circuitry
- Industry Standard 3-Wire Serial I/O
- Device Status Signal (Ready/Busy)
- Sequential Read Function
- 1,000,000 E/W Cycles
- Data Retention > 200 Years
- Pb-free and RoHS Compliant
- Temperature Ranges Supported:
 - Industrial (I) -40°C to +85°C
 - Automotive (E) -40°C to +125°C

Pin Function Table

Name	Function
CS	Chip Select
CLK	Serial Data Clock
DI	Serial Data Input
DO	Serial Data Output
Vss	Ground
PE	Program Enable – 93XX86C only
ORG	Memory Configuration – 93XX86C only
Vcc	Power Supply

Description:

The Microchip Technology Inc. 93XX86A/B/C devices are 16K bit low-voltage serial Electrically Erasable PROMs (EEPROM). Word-selectable devices such as the 93XX86C are dependent upon external logic levels driving the ORG pin to set word size. In the SOT-23 package, the 93XX86A devices provide dedicated 8-bit memory organization, while the 93XX86B devices provide dedicated 16-bit memory organization. A Program Enable (PE) pin allows the user to write-protect the entire memory array. Advanced CMOS technology makes these devices ideal for low-power, nonvolatile memory applications. The entire 93XX Series is available in standard packages including 8-lead PDIP and SOIC, and advanced packaging including 8-lead MSOP, 6-lead SOT-23, 8-lead 2x3 DFN and 8-lead TSSOP. All packages are Pb-free (Matte Tin) finish.

93AA86A/B/C, 93LC86A/B/C, 93C86A/B/C

Package Types (not to scale)

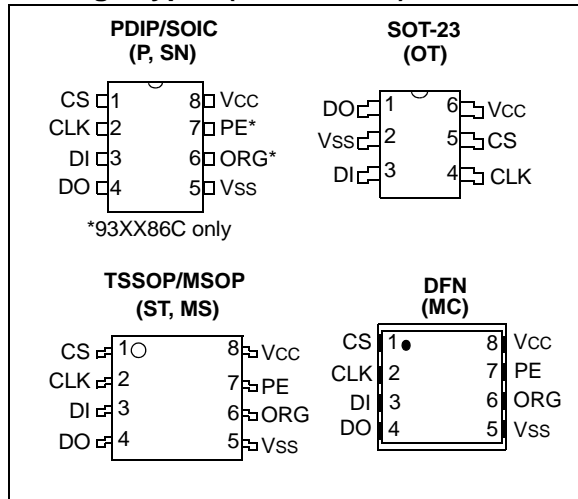

93AA86A/B/C, 93LC86A/B/C, 93C86A/B/C

1.0 ELECTRICAL CHARACTERISTICS

Absolute Maximum Ratings (†)

V _{CC}	7.0V
All inputs and outputs w.r.t. V _{SS}	-0.6V to V _{CC} +1.0V
Storage temperature	-65°C to +150°C
Ambient temperature with power applied.....	-40°C to +125°C
ESD protection on all pins	≥ 4 kV

† NOTICE: Stresses above those listed under “Absolute Maximum Ratings” may cause permanent damage to the device. This is a stress rating only and functional operation of the device at those or any other conditions above those indicated in the operational listings of this specification is not implied. Exposure to maximum rating conditions for extended periods may affect device reliability.

TABLE 1-1: DC CHARACTERISTICS

All parameters apply over the specified ranges unless otherwise noted.			Industrial (I): TA = -40°C to +85°C, V _{CC} = +1.8V to 5.5V Automotive (E): TA = -40°C to +125°C, V _{CC} = +2.5V to 5.5V				
Param. No.	Symbol	Parameter	Min.	Typ.	Max.	Units	Conditions
D1	V _{IH1}	High-level input voltage	2.0	—	V _{CC} +1	V	V _{CC} ≥ 2.7V
	V _{IH2}		0.7 V _{CC}	—	V _{CC} +1	V	V _{CC} < 2.7V
D2	V _{IL1}	Low-level input voltage	-0.3	—	0.8	V	V _{CC} ≥ 2.7V
	V _{IL2}		-0.3	—	0.2 V _{CC}	V	V _{CC} < 2.7V
D3	V _{OL1}	Low-level output voltage	—	—	0.4	V	I _{OL} = 2.1 mA, V _{CC} = 4.5V
	V _{OL2}		—	—	0.2	V	I _{OL} = 100 μA, V _{CC} = 2.5V
D4	V _{OH1}	High-level output voltage	2.4	—	—	V	I _{OH} = -400 μA, V _{CC} = 4.5V
	V _{OH2}		V _{CC} - 0.2	—	—	V	I _{OH} = -100 μA, V _{CC} = 2.5V
D5	I _{LI}	Input leakage current	—	—	±1	μA	V _{IN} = V _{SS} or V _{CC}
D6	I _{LO}	Output leakage current	—	—	±1	μA	V _{OUT} = V _{SS} or V _{CC}
D7	C _{IN} , C _{OUT}	Pin capacitance (all inputs/ outputs)	—	—	7	pF	V _{IN} /V _{OUT} = 0V (Note 1) TA = 25°C, F _{CLK} = 1 MHz
D8	I _{CC} write	Write current	—	—	3	mA	F _{CLK} = 3 MHz, V _{CC} = 5.5V
			—	500	—	μA	F _{CLK} = 2 MHz, V _{CC} = 2.5V
D9	I _{CC} read	Read current	—	—	1	mA	F _{CLK} = 3 MHz, V _{CC} = 5.5V
			—	—	500	μA	F _{CLK} = 2 MHz, V _{CC} = 3.0V
			—	100	—	μA	F _{CLK} = 2 MHz, V _{CC} = 2.5V
D10	I _{CCS}	Standby current	—	—	1	μA	I – Temp
			—	—	5	μA	E – Temp CLK = CS = 0V ORG = DI PE = V _{SS} or V _{CC} (Note 2) (Note 3)
D11	V _{POR}	V _{CC} voltage detect	—	1.5	—	V	(Note 1)
			—	3.8	—	V	93AA86A/B/C, 93LC86A/B/C 93C86A/B/C

- Note 1:** This parameter is periodically sampled and not 100% tested.
Note 2: ORG and PE pin not available on ‘A’ or ‘B’ versions.
Note 3: Ready/ $\overline{\text{Busy}}$ status must be cleared from DO; see **Section 3.4 “Data Out (DO)”**.

93AA86A/B/C, 93LC86A/B/C, 93C86A/B/C

TABLE 1-2: AC CHARACTERISTICS

All parameters apply over the specified ranges unless otherwise noted.			Industrial (I): TA = -40°C to +85°C, VCC = +1.8V to 5.5V Automotive (E): TA = -40°C to +125°C, VCC = +2.5V to 5.5V			
Param. No.	Symbol	Parameter	Min.	Max.	Units	Conditions
A1	FCLK	Clock frequency	—	3 2 1	MHz MHz MHz	4.5V ≤ VCC < 5.5V 2.5V ≤ VCC < 4.5V 1.8V ≤ VCC < 2.5V
A2	TCKH	Clock high time	200 250 450	—	ns ns ns	4.5V ≤ VCC < 5.5V 2.5V ≤ VCC < 4.5V 1.8V ≤ VCC < 2.5V
A3	TCKL	Clock low time	100 200 450	—	ns ns ns	4.5V ≤ VCC < 5.5V 2.5V ≤ VCC < 4.5V 1.8V ≤ VCC < 2.5V
A4	TCSS	Chip Select setup time	50 100 250	—	ns ns ns	4.5V ≤ VCC < 5.5V 2.5V ≤ VCC < 4.5V 1.8V ≤ VCC < 2.5V
A5	TCSH	Chip Select hold time	0	—	ns	1.8V ≤ VCC < 5.5V
A6	TCSL	Chip Select low time	250	—	ns	1.8V ≤ VCC < 5.5V
A7	TDIS	Data input setup time	50 100 250	—	ns ns ns	4.5V ≤ VCC < 5.5V 2.5V ≤ VCC < 4.5V 1.8V ≤ VCC < 2.5V
A8	TDIH	Data input hold time	50 100 250	—	ns ns ns	4.5V ≤ VCC < 5.5V 2.5V ≤ VCC < 4.5V 1.8V ≤ VCC < 2.5V
A9	TPD	Data output delay time	—	100 250 400	ns ns ns	4.5V ≤ VCC < 5.5V, CL = 100 pF 2.5V ≤ VCC < 4.5V, CL = 100 pF 1.8V ≤ VCC < 2.5V, CL = 100 pF
A10	TCZ	Data output disable time	—	100 200	ns ns	4.5V ≤ VCC < 5.5V, (Note 1) 1.8V ≤ VCC < 4.5V, (Note 1)
A11	TSV	Status valid time	—	200 300 500	ns ns ns	4.5V ≤ VCC < 5.5V, CL = 100 pF 2.5V ≤ VCC < 4.5V, CL = 100 pF 1.8V ≤ VCC < 2.5V, CL = 100 pF
A12	TWC	Program cycle time	—	5	ms	Erase/Write mode (AA and LC versions)
A13	TWC		—	2	ms	Erase/Write mode (93C versions)
A14	TEC		—	6	ms	ERAL mode, 4.5V ≤ VCC ≤ 5.5V
A15	TWL		—	15	ms	WRAL mode, 4.5V ≤ VCC ≤ 5.5V
A16	—		Endurance	1M	—	cycles

Note 1: This parameter is periodically sampled and not 100% tested.

Note 2: This application is not tested but ensured by characterization. For endurance estimates in a specific application, please consult the Total Endurance™ Model, which may be obtained from Microchip's web

93AA86A/B/C, 93LC86A/B/C, 93C86A/B/C

6-Lead Plastic Small Outline Transistor (OT) [SOT-23]

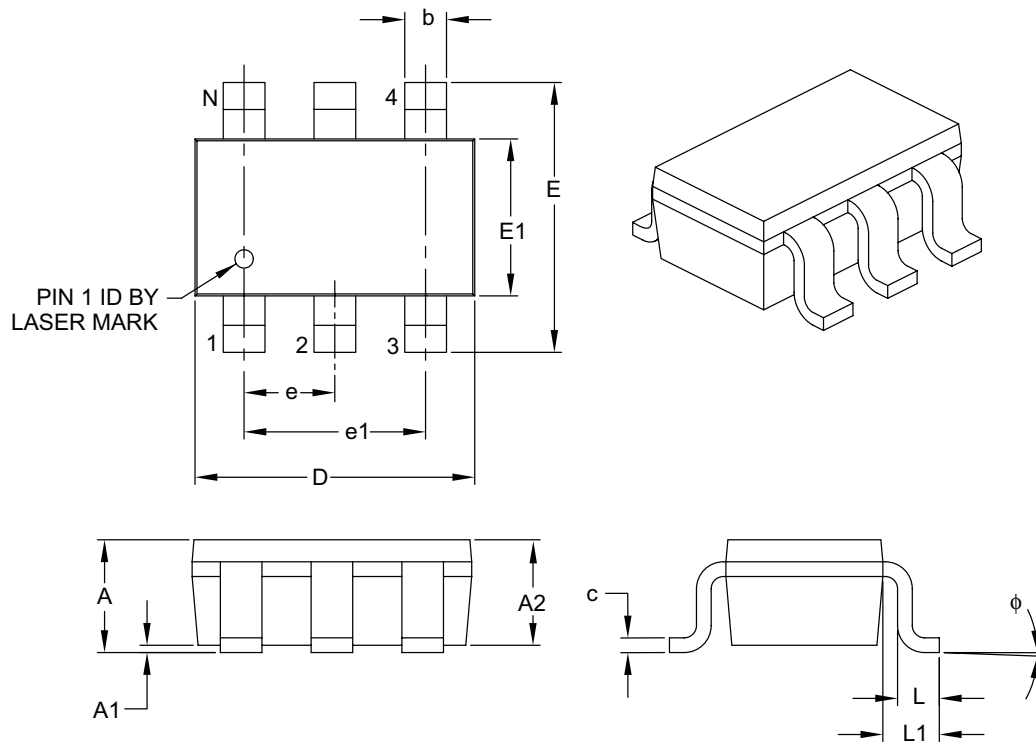

Dimension Limits	Units	MILLIMETERS		
		MIN	NOM	MAX
Number of Pins	N	6		
Pitch	e	0.95 BSC		
Outside Lead Pitch	e1	1.90 BSC		
Overall Height	A	0.90	–	1.45
Molded Package Thickness	A2	0.89	–	1.30
Standoff	A1	0.00	–	0.15
Overall Width	E	2.20	–	3.20
Molded Package Width	E1	1.30	–	1.80
Overall Length	D	2.70	–	3.10
Foot Length	L	0.10	–	0.60
Footprint	L1	0.35	–	0.80
Foot Angle	φ	0°	–	30°
Lead Thickness	c	0.08	–	0.26
Lead Width	b	0.20	–	0.51

Notes:

- Dimensions D and E1 do not include mold flash or protrusions. Mold flash or protrusions shall not exceed 0.127 mm per side.
- Dimensioning and tolerancing per ASME Y14.5M.

BSC: Basic Dimension. Theoretically exact value shown without tolerances.

Microchip Technology Drawing C04-028B

93AA86A/B/C, 93LC86A/B/C, 93C86A/B/C

PRODUCT IDENTIFICATION SYSTEM

To order or obtain information, e.g., on pricing or delivery, refer to the factory or the listed sales office.

<u>PART NO.</u>	<u>X</u>	<u>X</u>	<u>/XX</u>	<u>X</u>
Device	Tape & Reel	Temperature Range	Package	Lead Finish
<p>Device:</p> <p>93AA86A: 16K 1.8V Microwire Serial EEPROM (x8) 93AA86B: 16K 1.8V Microwire Serial EEPROM (x16) 93AA86C: 16K 1.8V Microwire Serial EEPROM w/ORG</p> <p>93LC86A: 16K 2.5V Microwire Serial EEPROM (x8) 93LC86B: 16K 2.5V Microwire Serial EEPROM (x16) 93LC86C: 16K 2.5V Microwire Serial EEPROM w/ORG</p> <p>93C86A: 16K 5.0V Microwire Serial EEPROM (x8) 93C86B: 16K 5.0V Microwire Serial EEPROM (x16) 93C86C: 16K 5.0V Microwire Serial EEPROM w/ORG</p>				
<p>Tape & Reel:</p> <p>Blank = Standard packaging T = Tape & Reel</p>				
<p>Temperature Range:</p> <p>I = -40°C to +85°C E = -40°C to +125°C</p>				
<p>Package:</p> <p>MS = Plastic MSOP (Micro Small outline, 8-lead) OT = SOT-23, 6-lead (Tape & Reel only) P = Plastic DIP (300 mil body), 8-lead SN = Plastic SOIC (3.90 mml body), 8-lead ST = TSSOP, 8-lead MC = 2x3 DFN, 8-lead</p>				
			<p>Examples:</p> <p>a) 93AA86C-I/MS: 16K, 2048x8 or 1024x16 Serial EEPROM, MSOP package, 1.8V b) 93AA86AT-I/OT: 16K, 2048x8 Serial EEPROM, SOT-23 package, tape and reel, 1.8V c) 93AA86CT-I/MS: 16K, 2048x8 or 1024x16 Serial EEPROM, MSOP package, tape and reel, 1.8V</p> <p>a) 93LC86C-I/MS: 16K, 2048x8, 1024x16 Serial EEPROM, MSOP package, 2.5V b) 93LC86BT-I/OT: 16K, 1024x16 Serial EEPROM, SOT-23 package, tape and reel, 2.5V</p> <p>a) 93C86C-I/MS: 16K, 2048x8 or 1024x16 Serial EEPROM, MSOP package, 5.0V b) 93C86AT-I/OT: 16K, 2048x8 Serial EEPROM, SOT-23 package, tape and reel, 5.0V</p>	