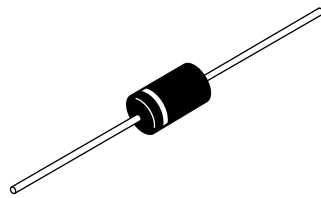
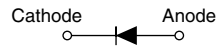

Schottky Rectifier, 1.0 A

DO-204AL

FEATURES

- Low profile, axial leaded outline
- High frequency operation
- Very low forward voltage drop
- High purity, high temperature epoxy encapsulation for enhanced mechanical strength and moisture resistance
- Guard ring for enhanced ruggedness and long term reliability
- Lead (Pb)-free plating
- Designed and qualified for industrial level

RoHS
COMPLIANT

PRODUCT SUMMARY

$I_{F(AV)}$	1.0 A
V_R	40 V
I_{RM}	12 mA at 125 °C

DESCRIPTION

The 1N5819 axial leaded Schottky rectifier has been optimized for very low forward voltage drop, with moderate leakage. Typical applications are in switching power supplies, converters, freewheeling diodes, and reverse battery protection.

MAJOR RATINGS AND CHARACTERISTICS

SYMBOL	CHARACTERISTICS	VALUES	UNITS
$I_{F(AV)}$	Rectangular waveform	1.0	A
V_{RRM}		40	V
I_{FSM}	$t_p = 5 \mu s$ sine	225	A
V_F	1 Apk, $T_J = 25 \text{ }^\circ\text{C}$	0.55	V
T_J	Range	- 40 to 150	$^\circ\text{C}$

VOLTAGE RATINGS

PARAMETER	SYMBOL	1N5819	UNITS
Maximum DC reverse voltage	V_R	40	V
Maximum working peak reverse voltage	V_{RWM}		

ABSOLUTE MAXIMUM RATINGS

PARAMETER	SYMBOL	TEST CONDITIONS		VALUES	UNITS
Maximum average forward current See fig. 4	$I_{F(AV)}$	50 % duty cycle at $T_L = 90 \text{ }^\circ\text{C}$, rectangular waveform		1.0	A
Maximum peak one cycle non-repetitive surge current See fig. 6	I_{FSM}	5 μs sine or 3 μs rect. pulse	Following any rated load condition and with rated V_{RRM} applied	225	
		10 ms sine or 6 ms rect. pulse		35	

ELECTRICAL SPECIFICATIONS					
PARAMETER	SYMBOL	TEST CONDITIONS		VALUES	UNITS
Maximum forward voltage drop See fig. 1	$V_{FM}^{(1)}$	1 A	$T_J = 25\text{ }^\circ\text{C}$	0.6	V
		2 A		0.73	
		3 A		0.9	
		1 A	$T_J = 125\text{ }^\circ\text{C}$	0.55	
		2 A		0.63	
		3 A		0.79	
Maximum reverse leakage current See fig. 2	$I_{RM}^{(1)}$	$T_J = 25\text{ }^\circ\text{C}$	$V_R = \text{Rated } V_R$	1.0	mA
		$T_J = 100\text{ }^\circ\text{C}$		6.0	
		$T_J = 125\text{ }^\circ\text{C}$		12	
Maximum junction capacitance	C_T	$V_R = 5\text{ }V_{DC}$ (test signal range 100 kHz to 1 MHz) 25 °C		60	pF
Typical series inductance	L_S	Measured lead to lead 5 mm from package body		8.0	nH
Maximum voltage rate of change	dV/dt	Rated V_R		10 000	V/ μ s

Note(1) Pulse width < 300 μ s, duty cycle < 2 %

THERMAL - MECHANICAL SPECIFICATIONS					
PARAMETER	SYMBOL	TEST CONDITIONS		VALUES	UNITS
Maximum junction and storage temperature range	T_J, T_{Stg}			- 40 to 150	$^\circ\text{C}$
Maximum thermal resistance, junction to lead	$R_{thJL}^{(1)}$	DC operation See fig. 4		80	$^\circ\text{C}/\text{W}$
Approximate weight				0.33	g
				0.012	oz.
Marking device		Case style DO-204AL (DO-41)		1N5819	

Note

(1) Mounted 1" square PCB, thermal probe connected to lead 2 mm from package

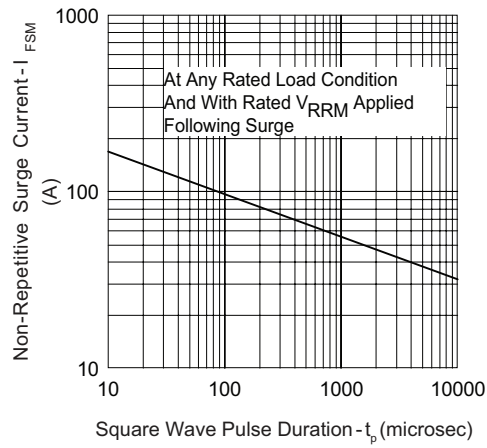

Fig. 6 - Typical Non-Repetitive Surge Current

ORDERING INFORMATION TABLE

Device code	1N5819	TR
	①	②
	1	- Part number: 1N5819 = 1 A, 40 V
	2	- TR = Tape and reel package (5000 pcs) None = Box package (1000 pcs)

Axial DO-204AL (DO-41)

DIMENSIONS in millimeters (inches)

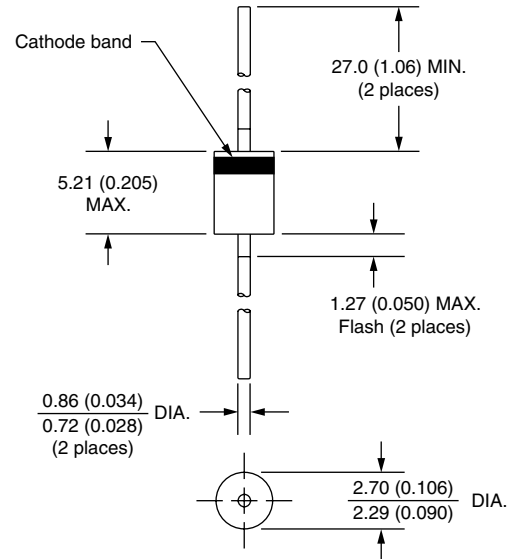
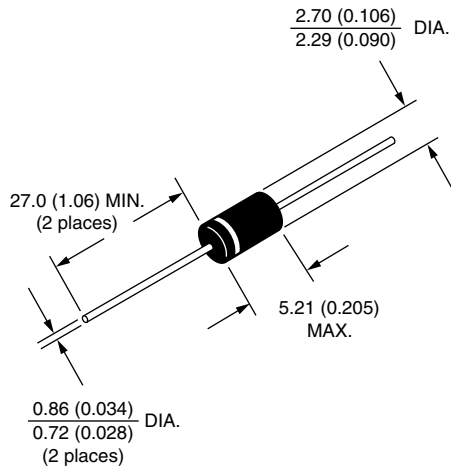

Schottky Axial < 4 A for DO-204AL (DO-41)

Axial devices are packed in accordance with EIA standard RS-296-D and specification.

COMPONENT OUTLINE	COMPONENT PITCH A ± 0.5 mm (0.020")	INNER TAPE PITCH B ± 1.5 mm (0.059")	CUMULATIVE PITCH TOLERANCE	QUANTITY PER REEL	QUANTITY PER CARTON
DO-41	5.0 mm	26.0 mm	2.0 mm/20 pitch	5000	20 000
DO-41	5.0 mm	52.4 mm	2.0 mm/10 pitch	5000	20 000

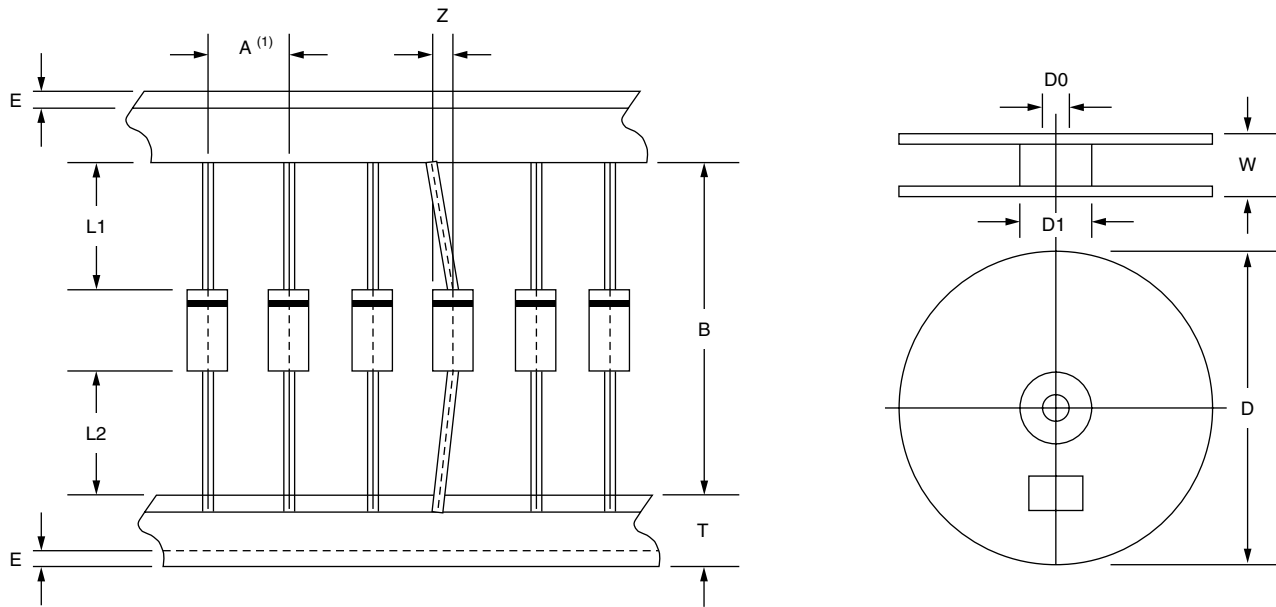

ITEM	SYMBOL	SPECIFICATIONS (mm)	SPECIFICATIONS (INCHES)
Component alignment	Z	1.2 maximum	0.048 maximum
Tape width	T	6.0 ± 0.4	0.236 ± 0.016
Exposed adhesive	E	0.8 maximum	0.032 maximum
Body eccentricity	L1-L2	1.0 maximum	0.040 maximum
Reel outside diameter	D	330.0	13.0
Reel inner diameter	D1	85.7 ± 0.3	3.375 ± 0.012
Feed hole diameter	D0	16.6 ± 0.4	0.655 ± 0.016
Reel width ⁽²⁾	W	79.0 ± 1.0	3.110 ± 0.040

Notes

(1) Each component lead shall be sandwiched between tapes for a minimum of 3.2 mm (0.126")

(2) The reel width "W" for 26 mm taping is 50.0 ± 1.0 mm (1.97" ± 0.040")