

High Intensity LED, \varnothing 5 mm Untinted Non-Diffused

Description

The TLH.51.. series is a clear, non diffused 5 mm LED for outdoor application.

These clear lamps utilize the highly developed technologies like AlInGaP and GaP.

The lens and the viewing angle is optimized to achieve best performance of light output and visibility.

The subtypes TLH.5101 and TLH.5102 with their very stable light output are especially recommended for applications where a homogeneous appearance is required.

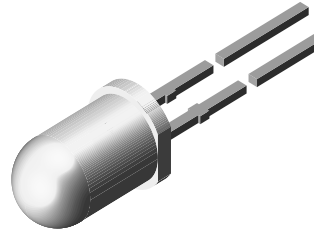

19223



Features

- Untinted non diffused lens
- Choice of four colors
- TLH.5101 and TLH.5102 with reduced light matching factor
- TLH.5100 for cost effective design
- Medium viewing angle
- Lead-free device

Applications

- Outdoor LED panels
- Central high mounted stop lights (CHMSL) for motor vehicles
- Instrumentation and front panel indicators
- Light guide design
- Traffic signals

Parts Table

Part	Color, Luminous Intensity	Angle of Half Intensity ($\pm\phi$)	Technology
TLHK5100	Red, $I_V > 320$ mcd	9 °	AlInGaP on GaAs
TLHE5100	Yellow, $I_V > 750$ mcd	9 °	AlInGaP on GaAs
TLHG5100	Green, $I_V > 240$ mcd	9 °	GaP on GaP
TLHG5101	Green, $I_V > 240$ mcd	9 °	GaP on GaP
TLHG5102	Green, $I_V > 240$ mcd	9 °	GaP on GaP
TLHP5100	Pure green, $I_V > 66$ mcd	9 °	GaP on GaP
TLHP5101	Pure green, $I_V > 66$ mcd	9 °	GaP on GaP
TLHP5102	Pure green, $I_V > 66$ mcd	9 °	GaP on GaP

Absolute Maximum Ratings

$T_{amb} = 25$ °C, unless otherwise specified

TLHK51.., TLHE51.., TLHG51.., TLHP51..

Parameter	Test condition	Symbol	Value	Unit
Reverse voltage		V_R	6	V
DC Forward current	$T_{amb} \leq 65$ °C	I_F	30	mA
Surge forward current	$t_p \leq 10$ μ s	I_{FSM}	1	A
Power dissipation	$T_{amb} \leq 65$ °C	P_V	100	mW
Junction temperature		T_j	100	°C

Parameter	Test condition	Symbol	Value	Unit
Operating temperature range		T_{amb}	- 40 to + 100	°C
Storage temperature range		T_{stg}	- 55 to + 100	°C
Soldering temperature	$t \leq 5$ s, 2 mm from body	T_{sd}	260	°C
Thermal resistance junction/ambient		R_{thJA}	350	K/W

Optical and Electrical Characteristics

$T_{amb} = 25$ °C, unless otherwise specified

Red

TLHK51..

Parameter	Test condition	Part	Symbol	Min	Typ.	Max	Unit
Luminous intensity ¹⁾	$I_F = 20$ mA	TLHK5100	I_V	320			mcd
Dominant wavelength	$I_F = 10$ mA		λ_d	626	630	639	nm
Peak wavelength	$I_F = 10$ mA		λ_p		643		nm
Angle of half intensity	$I_F = 10$ mA		ϕ		± 9		deg
Forward voltage	$I_F = 20$ mA		V_F		1.9	2.6	V
Reverse voltage	$I_R = 10$ μ A		V_R	5			V
Junction capacitance	$V_R = 0$, $f = 1$ MHz		C_j		15		pF

¹⁾ in one Packing Unit $I_{Vmin}/I_{Vmax} \leq 0.5$

Yellow

TLHE51..

Parameter	Test condition	Part	Symbol	Min	Typ.	Max	Unit
Luminous intensity ¹⁾	$I_F = 20$ mA	TLHE5100	I_V	750			mcd
Dominant wavelength	$I_F = 10$ mA		λ_d	581	588	594	nm
Peak wavelength	$I_F = 10$ mA		λ_p		590		nm
Angle of half intensity	$I_F = 10$ mA		ϕ		± 9		deg
Forward voltage	$I_F = 20$ mA		V_F		2	2.6	V
Reverse voltage	$I_R = 10$ μ A		V_R	5			V
Junction capacitance	$V_R = 0$, $f = 1$ MHz		C_j		15		pF

¹⁾ in one Packing Unit $I_{Vmin}/I_{Vmax} \leq 0.5$

Green

TLHG51..

Parameter	Test condition	Part	Symbol	Min	Typ.	Max	Unit
Luminous intensity ¹⁾	$I_F = 20 \text{ mA}$	TLHG5100	I_V	240			mcd
		TLHG5101	I_V	240		480	mcd
		TLHG5102	I_V	240		640	mcd
Dominant wavelength	$I_F = 10 \text{ mA}$		λ_d	562		575	nm
Peak wavelength	$I_F = 10 \text{ mA}$		λ_p		565		nm
Angle of half intensity	$I_F = 10 \text{ mA}$		φ		± 9		deg
Forward voltage	$I_F = 20 \text{ mA}$		V_F		2.4	3	V
Reverse voltage	$I_R = 10 \mu\text{A}$		V_R	6	15		V
Junction capacitance	$V_R = 0, f = 1 \text{ MHz}$		C_j		50		pF

¹⁾ in one Packing Unit $I_{Vmin}/I_{Vmax} \leq 0.5$

Pure green

TLHP51..

Parameter	Test condition	Part	Symbol	Min	Typ.	Max	Unit
Luminous intensity ¹⁾	$I_F = 20 \text{ mA}$	TLHP5100	I_V	66			mcd
		TLHP5101	I_V	66		132	mcd
		TLHP5102	I_V	66		200	mcd
Dominant wavelength	$I_F = 10 \text{ mA}$		λ_d	555		565	nm
Peak wavelength	$I_F = 10 \text{ mA}$		λ_p		555		nm
Angle of half intensity	$I_F = 10 \text{ mA}$		φ		± 9		deg
Forward voltage	$I_F = 20 \text{ mA}$		V_F		2.4	3	V
Reverse voltage	$I_R = 10 \mu\text{A}$		V_R	6	15		V
Junction capacitance	$V_R = 0, f = 1 \text{ MHz}$		C_j		50		pF

¹⁾ in one Packing Unit $I_{Vmin}/I_{Vmax} \leq 0.5$

Typical Characteristics ($T_{amb} = 25^\circ\text{C}$ unless otherwise specified)

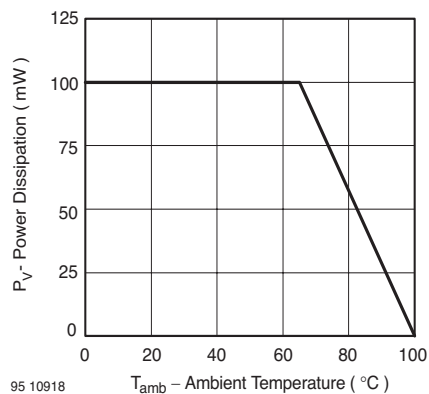

95 10918

Figure 1. Power Dissipation vs. Ambient Temperature

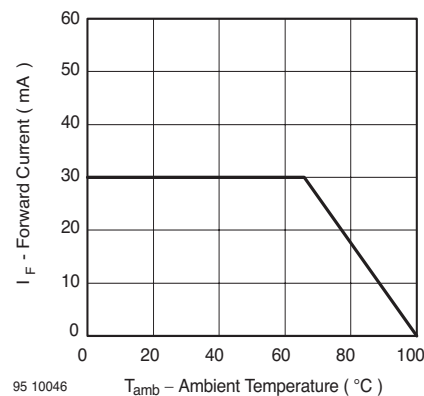

95 10046

Figure 2. Forward Current vs. Ambient Temperature

TLHE / G / K / P510.



Vishay Semiconductors

Package Dimensions in mm

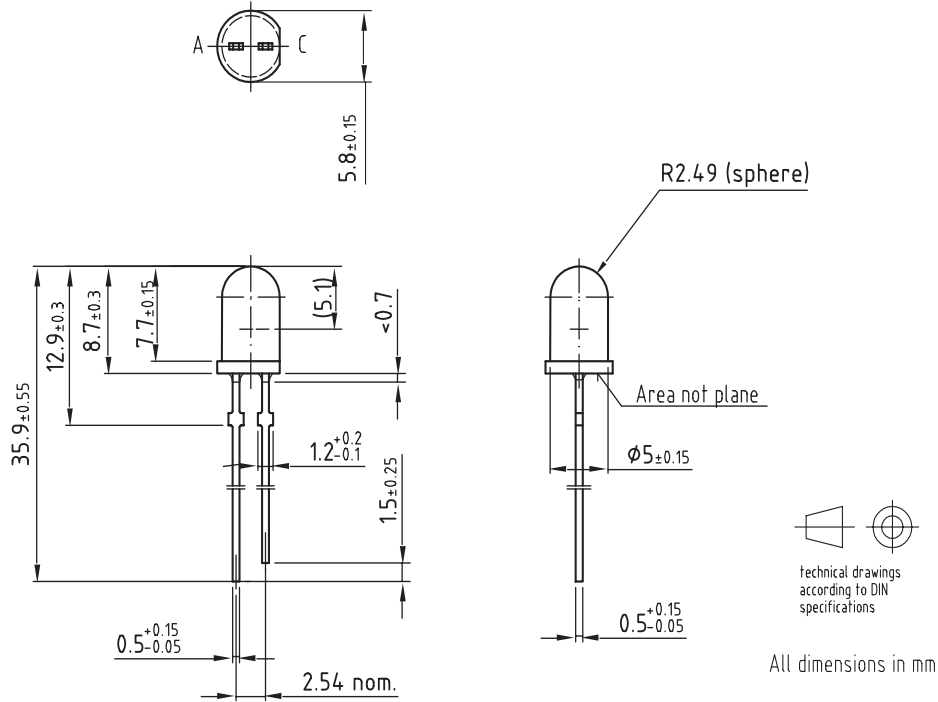

Drawing-No.: 6.544-5258.04-4
Issue: 6; 04.07.03

9612121