

GLC65 Commercial/GLM65 Medical

65 Watt Single Output Global Performance Switchers

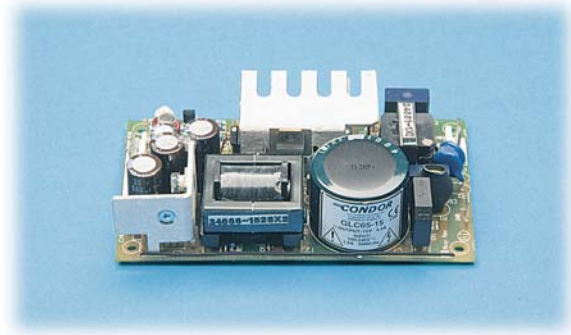

SPECIFICATIONS:

Ac Input

90-264 Vac, 47-63 Hz single phase.

Input Current

Maximum input current at minimum output voltage and output overload will be less than 1.7 A. Meets input current harmonic requirements of IEC1000-3-2.

Output Power

Normal continuous output power is 65 W, 75 W peak for 60 s. The 3.3 Vdc unit is 36.3 W and the 5 Vdc unit is 55 W continuous.

Hold-Up Time

20 ms from loss of ac input at 65 W load, from 120 Vac input.

Overload Protection

Fully protected against short circuit and output overload. Short circuit protection is cycling type power limit.

Output Noise

0.5% rms, 1% pk-pk, 20 MHz bandwidth, differential mode. Measured with scope probe directly across output terminals of the power supply with load terminated with 0.1 μ F capacitor.

Transient Response

Main output: 500 μ s typical response time for return to within 0.5% of final value for a 50% load step within the regulation limits of minimum and maximum load, $\Delta i/\Delta t < 0.2$ A/ μ s. Maximum voltage deviation is 3.5%. Startup/shutdown overshoot less than 3%.

Voltage Adjustment

Adjustable potentiometer capable of $\pm 5\%$ change from nominal setting.

Efficiency

82 to 94% minimum at full rated load, nominal input voltage, depending on model.

FEATURES:

- 4.1 W/in³
- Compact (3.0" x 5.0" x 1.06")
- Ultra-high efficiency (up to 94%) using patented technology
- Meets harmonic requirements of IEC1000-3-2, Class A
- Conducted EMI exceeds FCC Class B and CISPR 22 Class B (Commercial models) and CISPR 11 Class B (Medical models)
- 2-year warranty
- Exempt from line harmonics standard EN61000-3-2
- Commercial Approved to [UL1950](#), [IEC950](#), [EN60950](#), [CSA22.2 No. 950](#)
- Medical Approved to [UL2601](#), [EN60601](#), [CSA22.2 No. 601.1](#)
- Multiple output versions also available
- **CE** marked to LVD

Inrush Current

Inrush is limited by internal thermistor. The inrush at 240 Vac, averaged over the first ac half-cycle under cold start conditions will not exceed 37A.

EMI/EMC Compliance

All models include built-in EMI filtering to meet the following emissions requirements:

EMI SPECIFICATIONS	COMPLIANCE LEVEL
Conducted Emissions GLC65	EN55022 Class B; FCC Class B
Conducted Emissions GLM65	EN55011 Class B; FCC Class B
Static Discharge	EN61000-4-2, 6 kV contact, 8 kV air
RF Field Susceptibility	EN61000-4-3, 3 V/meter
Fast Transients/Bursts	EN61000-4-4, 2 kV, 5 kHz
Surge Susceptibility	EN61000-4-5, 1 kV diff., 2 kV com.

Commercial Leakage Current

Under normal conditions, leakage current is 425 μ A with 132 Vac @ 60 Hz input.

Commercial Safety

All GLC models are approved to [UL1950](#), [CSA22.2 No. 950](#), [IEC950](#) and [EN60950](#).

Medical Leakage Current

The maximum leakage current under single-fault conditions (254 Vac @ 50 Hz) is 120 μ A. Under normal conditions, leakage current is 31 μ A with 132 Vac @ 60 Hz input.

Medical Safety

All GLM models are approved to [UL2601](#), [CSA22.2 No. 601](#), [IEC601-1](#) and [EN60601](#). Consult factory for approval status.

GLC65 Commercial/GLM65 Medical 65 Watt Single Output

Commercial Model	Medical Model	Output	Current	Total Regulation	V1 Adjustment	V1 OVP Setpoint	Ripple and Noise
GLC65-5	GLM65-5	5.1 V	9 A	2%	±5%	6.2 ± 0.6 V	1%
GLC65-12	GLM65-12	12 V	5.5 A	2%	±5%	14 ± 1.1 V	1%
GLC65-15	GLM65-15	15 V	4.3 A	2%	±5%	18.5 ± 1.5 V	1%
GLC65-18	GLM65-18	18 V	3.6 A	2%	±5%	21.7 ± 2.0 V	1%
GLC65-24	GLM65-24	24 V	2.7 A	2%	±5%	28 ± 2.5 V	1%
GLC65-28	GLM65-28	28 V	2.3 A	2%	±5%	34 ± 2.8 V	1%
GLC65-48	GLM65-48	48 V	1.35 A	2%	±5%	55 ± 4.0 V	1%

GLC65/GLM65 MECHANICAL SPECIFICATIONS

INPUT J1:
AMP P/N 640445-3, .156 [3.96mm] CTR,
0.045 [1.14mm] SQUARE PIN HEADER
PIN 3) AC NEUTRAL
PIN 2) NO PIN
PIN 1) AC LINE

OUTPUT J2:
AMP P/N 640445-6, .156 [3.96mm] CTR,
0.045 [1.14mm] SQUARE PIN HEADER

PIN 1-3) OUTPUT
PIN 4-6) COMMON
GND: 0.250" FASTON TAB

SENSE J3:
AMP P/N 640456-2, .100 [2.54mm] CTR,
0.025 [0.64mm] SQUARE PIN HEADER

PIN 1) +SENSE
PIN 2) -SENSE

MATING CONNECTORS: AMP P/N

	HOUSING	CONTACTS
INPUT	640250-3	770476-1
OUTPUT	640250-6	770476-1
SENSE	640440-2	770476-1

NOTE: 5A MAXIMUM RECOMMENDED CURRENT
PER CONNECTOR PIN

WEIGHT: 5 OZ.
[0.142 KG]

TOLERANCES:
X.XX = ± 0.030 (0.76MM)
X.XXX = ± 0.010 (0.25MM)

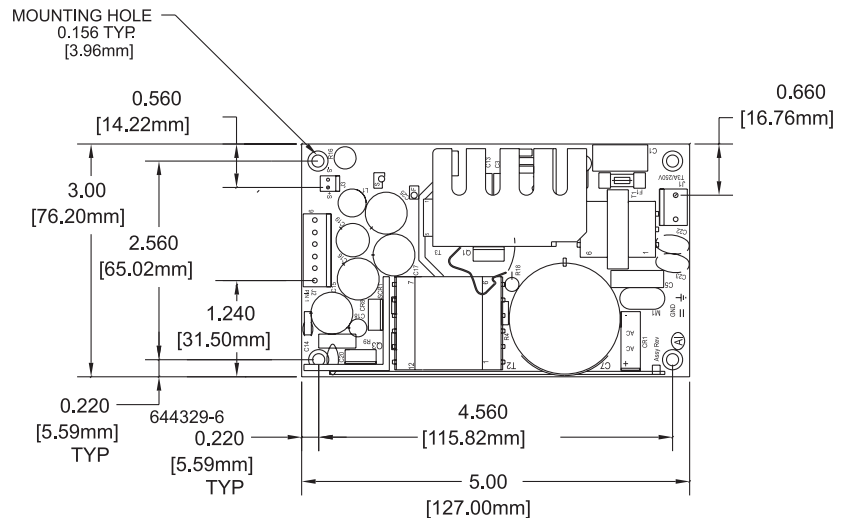

MAX. COMPONENT HEIGHT 1.20" [30.28 mm]
MAX. LEAD PROTRUSION 0.10" [2.54mm]

Environmental Specification	Operating	Non-operating
Temperature (A)	0 to 50°C	-40 to +85°C
Humidity (A)	0 to 95% RH	0 to 95% RH
Shock (B)	20 g _{pk}	40 g _{pk}
Altitude	-500 to 10,000 ft	-500 to 40,000 ft
Vibration (C)	1.5 g _{rms} , 0.003 g ² /Hz	5 g _{rms} , 0.026 g ² /Hz

- Units should be allowed to warm up/operate under non-condensing conditions before application of power. Derate output current and total output power by 2.5% per °C above 50°C.
- Shock testing—half-sinusoidal, 10 ± 3 ms duration, ± direction, 3 orthogonal axes, total 6 shocks.
- Random vibration—10 to 2000Hz, 6dB/octave roll-off from 350 to 2000Hz, 3 orthogonal axes. Tested for 10 min./axis operating and 1 hr./axis non-operating.