

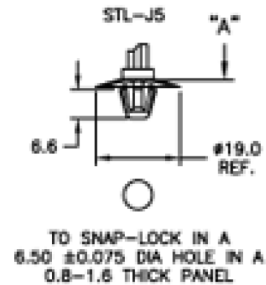

See "Part Drawing" for Details

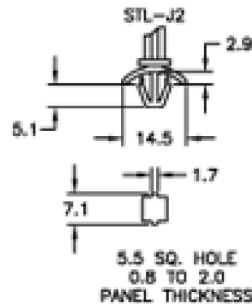

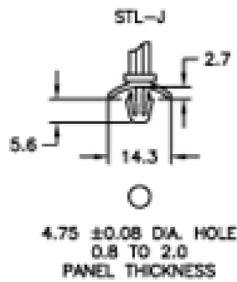
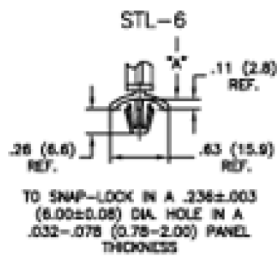
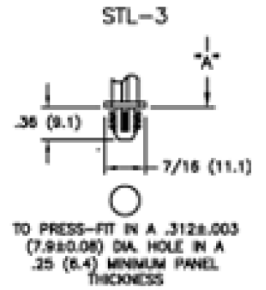
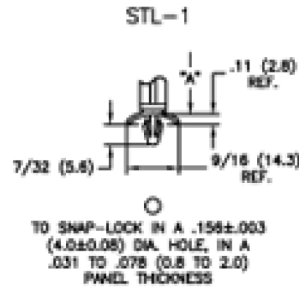
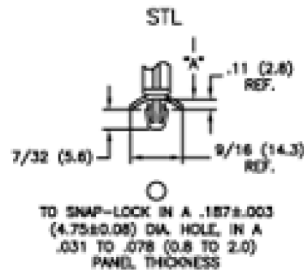
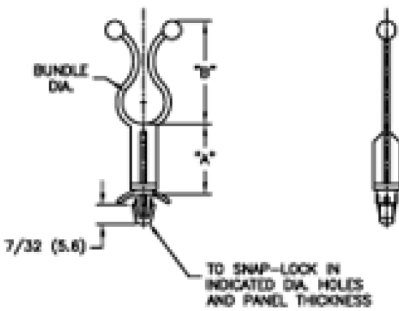

Part Number	Description
<a href="#">STL-8-450-2-01</a>	Twist Lock,Spcr,Nat,.40"-.50" Hold 

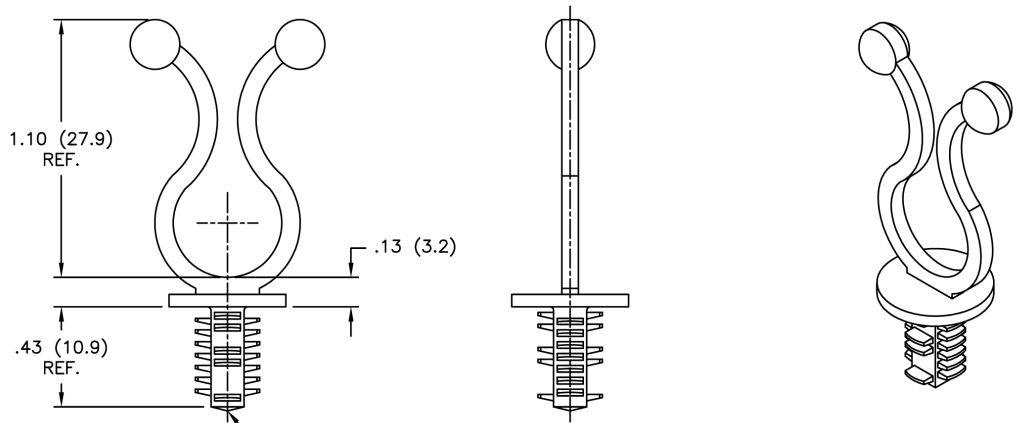

TO PRESS FIT IN A  $.250 \pm .003$   
 $(6.35 \pm 0.075)$  DIA. HOLE IN A  
 $.28 (0.72)$  MIN. THICK BOARD

NOTES:

1. MATERIAL: NYLON 6/6 (RMS-01).  
 FLAME RETARDANT NYLON (RMS-19),  
 AVAILABLE BY SPECIAL ORDER.
2. COLOR: NATURAL.
3. STANDARD PACK QUANTITY: 1000.
4. BUNDLE DIA.  $.40-.50 (10.2-12.7)$

B		SEE ECN #502 FOR CHANGS	SM 10.25.02	TITLE: STANDOFF TWIST LOCK BLIND HOLE FIX		 DWG IN IN (MM)		
A		REDRAWN FROM RICHCO UK (REV. B)	SM 02.28.02	FILE # STL-8-450	DWN: SM			APP:
REV		DESCRIPTION	ENGR DATE	TOLERANCES UNLESS NOTED .XX=±.010 .XXX=±.005 FRAC=±1/64 ANG=±1°	MAT'L: SEE NOTES	DT: 02/28/02	DT:	PART #
				RE: RICHCO, INC.	RICHCO INC.			STL-8-450-2-01
								PRINT TYPE CA