

Convergent Reflective Micro Photoelectric Sensor

The PM2 series of micro photoelectric sensors offers a convergent reflective sensing solution for incredibly stable sensing. Because the sensor only detects in a limited area, it is not affected by background objects, color, or reflectivity. Small objects down to 0.05mm can be detected reliably as well. Three sensor head styles are available in both connector and cable types. One control output is provided (NPN).

Model Name	Type	Output Operation	Output Configuration	Emitting Element	Max. Range (mm)	Max. Range (in)
Sort ▲ ▼	Sort ▲ ▼	Sort ▲ ▼	Sort ▲ ▼	Sort ▲ ▼	Sort ▲ ▼	Sort ▲ ▼
PM2-LF10B-C1	Convergent Reflective, Front Sensing, Cable Type	Dark-ON	NPN	Infrared LED	8	0.315
PM2-LF10-C1	Convergent Reflective, Front Sensing, Cable Type	Light-ON	NPN	Infrared LED	8	0.315
PM2-LH10B-C1	Convergent Reflective, Top Sensing, Cable Type	Dark-ON	NPN	Infrared LED	8	0.315
PM2-LH10-C1	Convergent Reflective, Top Sensing, Cable Type	Light-ON	NPN	Infrared LED	8	0.315
PM2-LL10B-C1	Convergent Reflective, L Type, Top Sensing, Cable Type	Dark-ON	NPN	Infrared LED	8	0.315
PM2-LL10-C1	Convergent Reflective, L Type, Top Sensing, Cable Type	Light-ON	NPN	Infrared LED	8	0.315

PM2

DIMENSIONS (Unit: mm in)

PM2-LH10-C1
PM2-LH10B-C1 Sensor

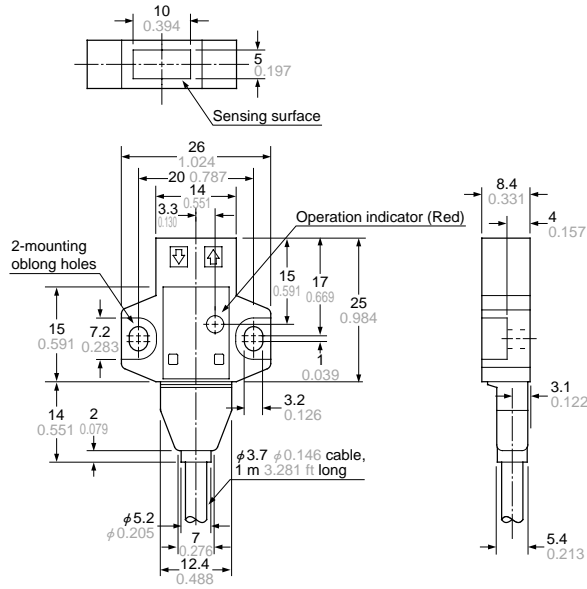

PM2-LF10-C1
PM2-LF10B-C1 Sensor

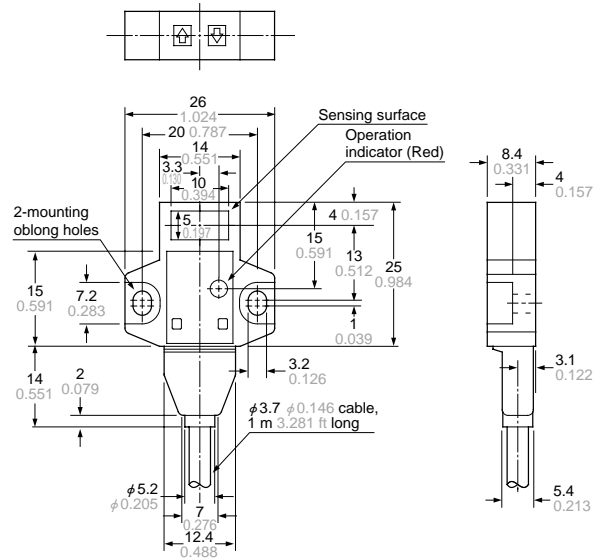

PM2-LL10-C1
PM2-LL10B-C1 Sensor

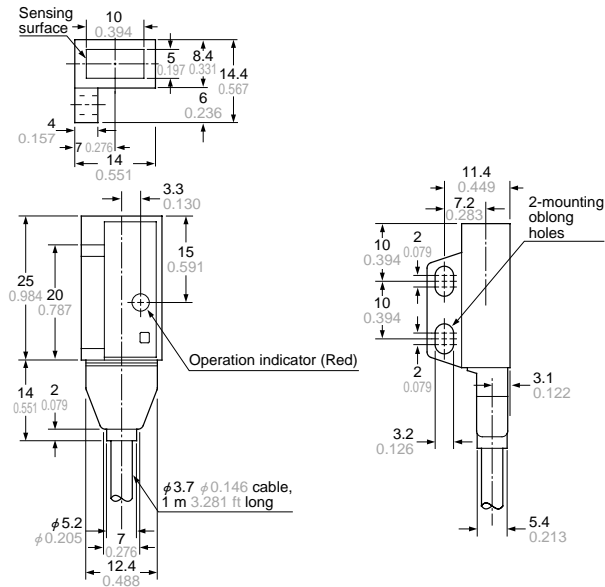

PM2

SPECIFICATIONS

Item	Model No.	Type	Connector type			Cable type		
			Top sensing	Front sensing	L type (Top sensing)	Top sensing	Front sensing	L type (Top sensing)
			Light-ON	PM2-LH10	PM2-LF10	PM2-LL10	PM2-LH10-C1	PM2-LF10-C1
Dark-ON	PM2-LH10B	PM2-LF10B	PM2-LL10B	PM2-LH10B-C1	PM2-LF10B-C1	PM2-LL10B-C1		
Sensing range		2.5 to 8 mm 0.098 to 0.315 in (Conv. point: 5 mm 0.197 in) with white non-glossy paper (15 × 15 mm 0.591 in × 0.591 in) (Note 1)						
Min. sensing object		φ0.05 mm φ0.002 in copper wire (Setting distance: 5 mm 0.197 in)						
Hysteresis		20 % or less of operation distance with white non-glossy paper (15 × 15 mm 0.591 × 0.591 in)						
Repeatability (perpendicular to sensing axis)		0.08 mm 0.003 in or less (Note 2)						
Supply voltage		5 to 24 V DC ± 10 % Ripple P-P 5 % or less						
Current consumption		Average: 25 mA or less, Peak: 80 mA or less						
Output		NPN open-collector transistor <ul style="list-style-type: none"> • Maximum sink current: 100 mA • Applied voltage: 30 V DC or less (between output and 0 V) • Residual voltage: 1 V or less (at 100 mA sink current) 0.4 V or less (at 16 mA sink current) 						
Utilization category		DC-12 or DC-13						
Short-circuit protection		Incorporated						
Response time		0.8 ms or less						
Operation indicator		Red LED (lights up when the output is ON)						
Environmental resistance	Pollution degree		3 (Industrial environment)					
	Ambient temperature		− 10 to + 55 °C + 14 to + 131 °F (No dew condensation or icing allowed), Storage: − 25 to + 80 °C − 13 to + 176 °F					
	Ambient humidity		45 to 85 % RH, Storage: 45 to 85 % RH					
	Ambient illuminance		Sunlight: 11,000 lx at the light-receiving face, Incandescent light: 3,500 lx at the light-receiving face					
	EMC		EN 50081-2, EN 50082-2, EN 60947-5-2					
	Vibration resistance		10 to 55 Hz frequency, 1.5 mm 0.059 in amplitude in X, Y and Z directions for two hours each					
	Shock resistance		500 m/s ² acceleration (50 G approx.) in X, Y and Z directions for three times each					
Emitting element		Infrared LED (modulated)						
Material		Enclosure: Polycarbonate, Terminal part: HSM (Ag plated)			Enclosure: Polycarbonate, Fixed cable part: PBT			
Cable		_____			0.2 mm ² 3-core cabtyre cable, 1 m 3.281 ft long (Note 3)			
Cable extension		Total 2 m 6.562 ft is possible with 0.3 mm ² , or more, cable. / If the cable is extended for 2 m 6.562 ft, or more, a capacitor of 10 μF must be connected between +V and 0 V terminals.			_____			
Weight		4.5 g approx.		4 g approx.		25 g approx.		

Notes: 1) The sensing range may extend up to 12.5 mm 0.492 in with white non-glossy paper due to product variation.
 2) The repeatability is specified for white non-glossy paper (15 × 15 mm 0.591 × 0.591 in) at a setting distance of 5 mm 0.197 in.
 3) Cable cannot be extended.