

Dual Rod Cylinder Series CXS

ø6, ø10, ø15, ø20, ø25, ø32

Dual rod cylinder with guide function for pick & place applications.

Series CXS

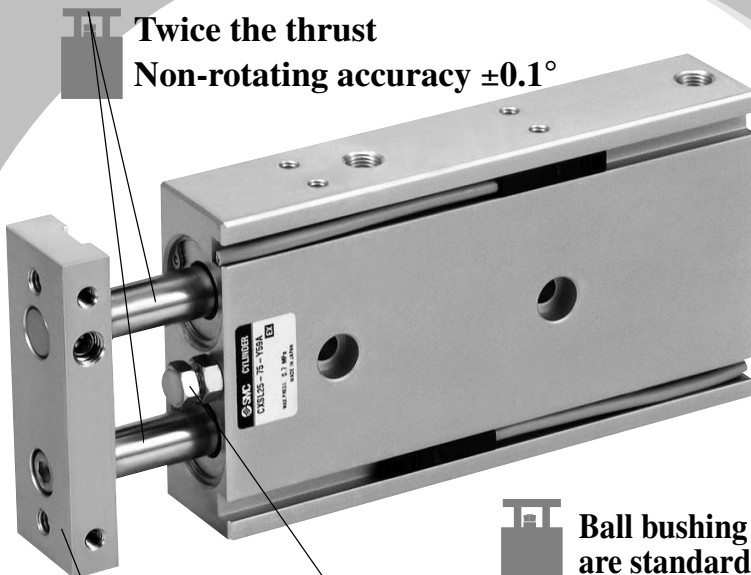

Twice the thrust
Non-rotating accuracy $\pm 0.1^\circ$

Ball bushing bearings and slide bearings are standard for all series.

Dimensions for ball bushing bearings and slide bearings are the same.

Adjustable stroke range:
0 to -5 mm

Work can be mounted on three faces.

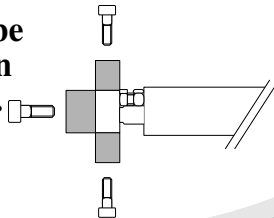

- MX
- MTS
- MY
- CY
- MG
- CX**
- D-
- X
- 20-
- Data

Series Variations

Series	Bore size (mm) 6 10 15 20 25 32	Axial foot piping	Clean Series 11- 12-	Page
Compact type CXSJ	● ● ● ● ● ●	●	(Ball bushing bearing only)	8-28-18
Basic type CXS	● ● ● ● ● ●	(ø6 only)	(Ball bushing bearing only)	8-29-1
With air cushion CXS	● ● ● ● ● ●			8-29-11
With end lock CXS	● ● ● ● ● ●			8-29-18
Double rod type CXSW	● ● ● ● ● ●			8-29-24

Dual Rod Cylinder: Basic Type

Series CXS

ø6, ø10, ø15, ø20, ø25, ø32

How to Order

CXS **M** **20** **100** **Y7BW** **S**

Bearing type

M	Slide bearing
L	Ball bushing bearing

Bore size/Stroke (mm)

Bore size (mm)	Standard stroke
6	10, 20, 30, 40, 50
10	10, 15, 20, 25, 30, 35, 40, 45, 50, 60, 70, 75
15, 20, 25, 32	10, 15, 20, 25, 30, 35, 40, 45, 50, 60, 70, 75, 80, 90, 100

Number of auto switches

Nil	2 pcs.
S	1 pc.
n	"n" pcs.

Auto switch

Nil Without auto switch (Built-in magnet)

* For the applicable auto switch model, refer to the table below.
* Auto switches are shipped together, (but not assembled).

MX

MTS

MY

CY

MG

CX

D-

-X

20-

Data

Applicable Auto Switch/Refer to page 8-30-1 for further information on auto switches.

Type	Special function	Electrical entry	Indicator light	Wiring (Output)	Load voltage			Auto switch model		Lead wire length (m) *			Pre-wire connector	Applicable load	
					DC	AC	Perpendicular	In-line	0.5 (Nil)	3 (L)	5 (Z)	IC circuit		Relay, PLC	
Reed switch	—	Grommet	Yes	3-wire (NPN equivalent)	—	5 V	—	—	Z76	●	●	—	—	IC circuit	—
				2-wire	24 V	12 V	100 V	—	Z73	●	●	●	—	—	Relay, PLC
Solid state switch	—	Grommet	Yes	3-wire (NPN)	24 V	5 V, 12 V	—	Y69A	Y59A	●	●	○	○	IC circuit	Relay, PLC
				3-wire (PNP)				Y7PV	Y7P	●	●	○	○		
				2-wire				Y69B	Y59B	●	●	○	○		
	3-wire (NPN)			Y7NVV	Y7NV	●	●	○	○	IC circuit					
	3-wire (PNP)			Y7PWV	Y7PW	●	●	○	○	IC circuit					
	2-wire			Y7BWW	Y7BW	●	●	○	○						
Water resistant (2-color indication)	—	—	—	—	12 V	—	Y7BA	—	—	●	○	○	—		

* Lead wire length symbols: 0.5 m Nil (Example) Y59A
3 m L (Example) Y59AL
5 m Z (Example) Y59AZ

* Solid state switches marked with "○" are produced upon receipt of order.

- Since there are other applicable auto switches than listed, refer to page 8-29-10 for details.
- For details about auto switches with pre-wire connector, refer to page 8-30-52.

Series CXS



Specifications

Bore size (mm)	6	10	15	20	25	32
Fluid	Air (Non-lube)					
Proof pressure	1.05 MPa					
Maximum operating pressure	0.7 MPa					
Minimum operating pressure	0.15 MPa	0.1 MPa		0.05 MPa		
Ambient and fluid temperature	-10 to 60°C (No freezing)					
Piston speed	30 to 300 mm/s	30 to 800 mm/s	30 to 700 mm/s		30 to 600 mm/s	
Cushion	Rubber bumper					
Stroke adjustable range	0 to -5 mm compared to the standard stroke					
Port size	M5 x 0.8				Rc 1/8	
Bearing type	Slide bearing, Ball bushing bearing (Same dimensions for both)					

* The maximum piston speed shown in the table above is for extension.
The maximum piston speed for retraction is approximately 70% that of extension.

Standard Stroke

Model	Standard stroke	Manufacturable stroke range
CXS□6	10, 20, 30, 40, 50	60 to 100
CXS□10	10, 15, 20, 25, 30, 35, 40, 45, 50, 60, 70, 75	80 to 150
CXS□15	10, 15, 20, 25, 30, 35, 40, 45, 50, 60, 70, 75, 80, 90, 100	110 to 150
CXS□20		110 to 200
CXS□25		
CXS□32		

* Refer to "Made to Order Specifications" for stroke which exceeds the standard stroke length.
Non-standard strokes for a size ø6 cylinder are available as a special order.

Theoretical Output

Bore size (mm)	Rod size (mm)	Operating direction	Piston area (mm ²)	Operating pressure (MPa)								
				0.1	0.15	0.2	0.3	0.4	0.5	0.6	0.7	
CXS□6	4	OUT	56	—	8.4	11.2	16.8	22.4	28.0	33.6	39.2	
		IN	31	—	4.6	6.2	9.3	12.4	15.5	18.6	21.7	
CXS□10	6	OUT	157	15.7	—	31.4	47.1	62.8	78.5	94.2	110	
		IN	100	10.0	—	20.0	30.0	40.0	50.0	60.0	70.0	
CXS□15	8	OUT	353	35.3	—	70.6	106	141	177	212	247	
		IN	252	25.2	—	50.4	75.6	101	126	151	176	
CXS□20	10	OUT	628	62.8	—	126	188	251	314	377	440	
		IN	471	47.1	—	94.2	141	188	236	283	330	
CXS□25	12	OUT	982	98.2	—	196	295	393	491	589	687	
		IN	756	75.6	—	151	227	302	378	454	529	
CXS□32	16	OUT	1608	161	—	322	482	643	804	965	1126	
		IN	1206	121	—	241	362	482	603	724	844	

Note) Theoretical output (N) = Pressure (MPa) x Piston area (mm²)



Made to Order Specifications
(For details, refer to page 8-31-1.)

Symbol	Specifications
-XB6	Heat resistant cylinder (150°C)
-XB9	Low speed cylinder (10 to 50 mm/s)
-XB11	Long stroke type
-XB13	Low speed cylinder (5 to 50 mm/s)
-XB19	High speed cylinder
-XC18	NPT finish piping port
-XC22	Fluoro rubber seals
-X593	Without plate

Weight

Model	Standard stroke (mm)														
	10	15	20	25	30	35	40	45	50	60	70	75	80	90	100
CXSM6	0.081	—	0.095	—	0.108	—	0.122	—	0.135	—	—	—	—	—	—
CXSL6	0.081	—	0.095	—	0.108	—	0.122	—	0.135	—	—	—	—	—	—
CXSM10	0.15	0.16	0.17	0.18	0.19	0.20	0.21	0.22	0.23	0.25	0.27	0.28	—	—	—
CXSL10	0.15	0.16	0.17	0.18	0.19	0.20	0.21	0.22	0.23	0.25	0.27	0.28	—	—	—
CXSM15	0.25	0.265	0.28	0.29	0.30	0.315	0.33	0.345	0.36	0.39	0.42	0.435	0.45	0.48	0.51
CXSL15	0.27	0.285	0.30	0.31	0.32	0.335	0.35	0.365	0.38	0.41	0.44	0.455	0.47	0.50	0.53
CXSM20	0.40	0.42	0.44	0.46	0.48	0.495	0.51	0.53	0.55	0.585	0.62	0.64	0.66	0.70	0.74
CXSL20	0.43	0.445	0.46	0.48	0.50	0.515	0.53	0.55	0.57	0.605	0.64	0.66	0.68	0.715	0.75
CXSM25	0.61	0.635	0.66	0.69	0.72	0.745	0.77	0.80	0.83	0.89	0.95	0.97	0.995	1.06	1.10
CXSL25	0.62	0.645	0.67	0.70	0.73	0.755	0.78	0.81	0.84	0.895	0.955	0.98	1.005	1.065	1.11
CXSM32	1.15	1.19	1.23	1.275	1.32	1.36	1.40	1.45	1.49	1.58	1.665	1.71	1.755	1.84	1.93
CXSL32	1.16	1.205	1.25	1.295	1.34	1.38	1.42	1.465	1.51	1.595	1.68	1.72	1.765	1.855	1.94

Construction: Slide Bearing

CXSM6

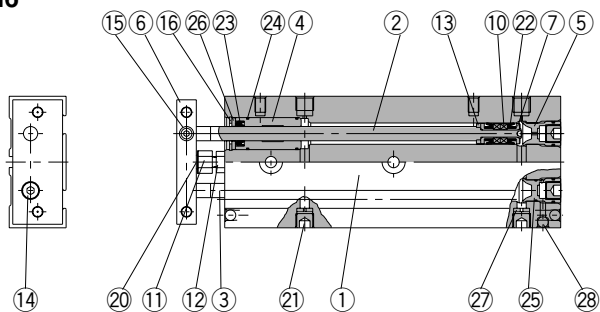

CXSM10

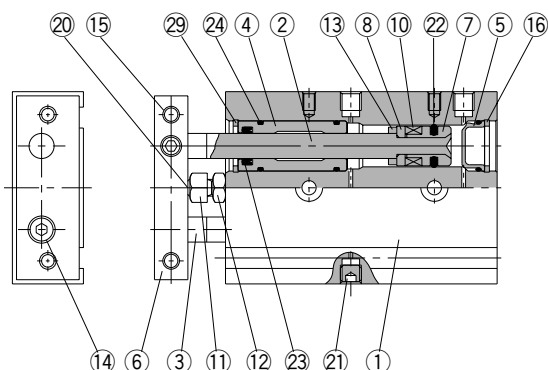

CXSM15

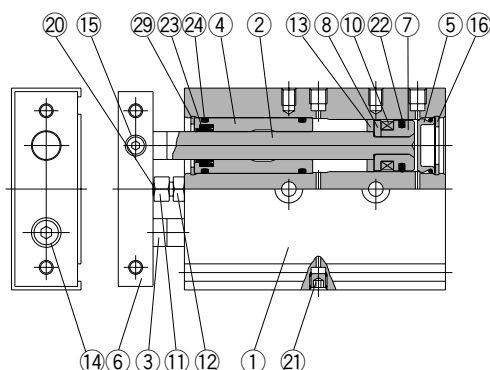

CXSM20 to 32

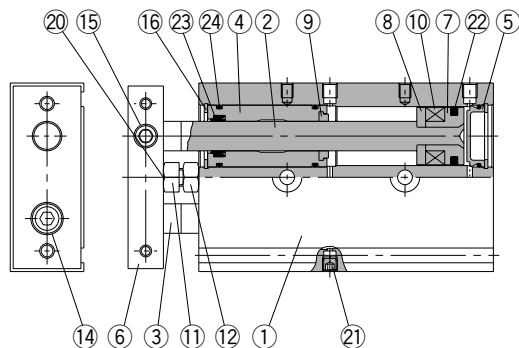

- MX
- MTS
- MY
- CY
- MG
- CX**
- D-
- X
- 20-
- Data

Component Parts

No.	Description	Material	Note
①	Housing	Aluminum alloy	Hard anodized
②	Piston rod A	Carbon steel ⁽¹⁾	Hard chrome plated
③	Piston rod B	Carbon steel ⁽¹⁾	Hard chrome plated
④	Rod cover	Aluminum bearing alloy	
⑤	Head cover	Special steel ⁽²⁾	
⑥	Plate	Aluminum alloy	Hard anodized
⑦	Piston A	Aluminum alloy	Chromated
⑧	Piston B	Aluminum alloy	Chromated
⑨	Bumper A	Polyurethane	
⑩	Magnet	Magnetic material	
⑪	Bumper bolt	Carbon steel	Nickel plated
⑫	Hexagon nut	Carbon steel	Nickel plated
⑬	Bumper B	Polyurethane	
⑭	Hexagon socket head cap screw	Chromium steel	Nickel plated
⑮	Hexagon socket head set screw	Chromium steel	Nickel plated
⑯	Snap ring	Special steel	Nickel plated
⑰	Bumper holder	Aluminum bearing alloy	



Note 1) Stainless steel for CXSM6.
 Note 2) Anodized aluminum alloy for CXSM6.

Component Parts

No.	Description	Material	Note
⑱	Ball bushing	—	
⑲	Bearing spacer	Aluminum bearing alloy	
⑳	Bumper	Polyurethane	
㉑	Plug	Chromium steel	Nickel plated
㉒	Piston seal	NBR	
㉓	Rod seal	NBR	
㉔	O-ring	NBR	
㉕	Head cover B	Aluminum alloy	Nickel plated
㉖	Seal retainer	Aluminum alloy	
㉗	Port spacer	Aluminum alloy	
㉘	Steel ball	Special steel	Hard chrome plated
㉙	Snap ring B	Special steel	Nickel plated

Replacement Parts: Seal Kit

Bore size (mm)	Kit no.	Contents
6	CXSM6-PS	Set of nos. above ㉒, ㉓, ㉔
10	CXSM10APS	
15	CXSM15-PS	
20	CXSM20-PS	
25	CXSM25-PS	
32	CXSM32-PS	

* Seal kit includes ㉒, ㉓, ㉔. Order the seal kit, based on each bore size.

Series CXS

Dimensions: $\varnothing 10$, $\varnothing 15$

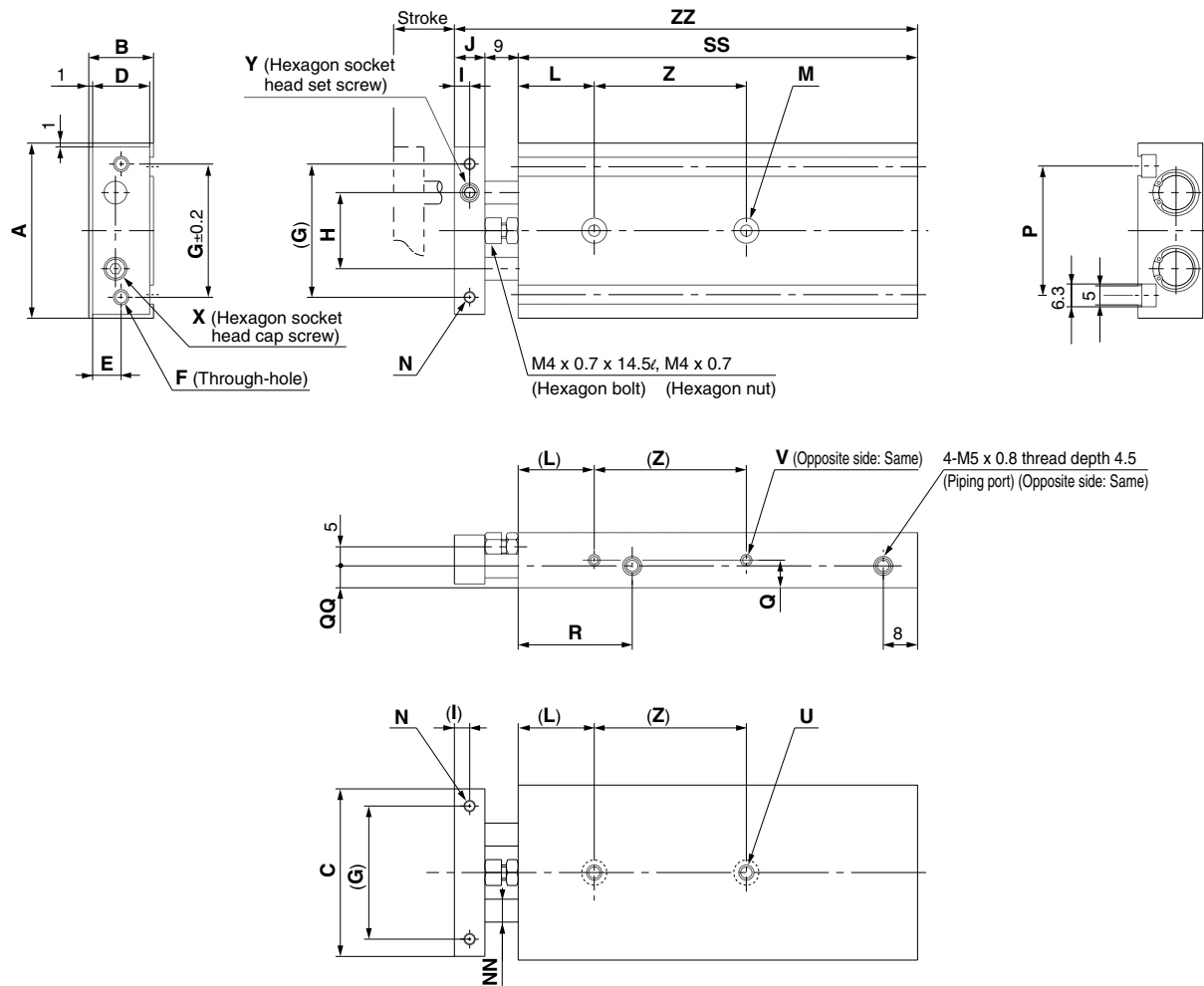

(mm)

Model	A	B	C	D	E	F	G	H	I	J	L	M	N	NN	P	Q	QQ	R	U	V	X	Y
CXS□10	46	17	44	15	7.5	2-M4 x 0.7	35	20	4	8	20	2- $\varnothing 3.4$ through 2- $\varnothing 6.5$ counter-bore depth 3.3	2-M3 x 0.5 thread depth 5	$\varnothing 6$	33.6	8.5	7	30	2-M4 x 0.7 thread depth 7	4-M3 x 0.5 thread depth 4.5	M3 x 0.5 x 10z	M5 x 0.8 x 5z
CXS□15	58	20	56	18	9	2-M5 x 0.8	45	25	5	10	30	2- $\varnothing 4.3$ through 2- $\varnothing 8$ counter-bore depth 4.4	2-M4 x 0.7 thread depth 6	$\varnothing 8$	48	10	10	38.5	2-M5 x 0.8 thread depth 8	4-M4 x 0.7 thread depth 5	M5 x 0.8 x 10z	M6 x 1.0 x 5z

Dimensions by Stroke

(mm)

Model	SS																Z					ZZ																
	10	15	20	25	30	35	40	45	50	60	70	75	80	90	100	10	15	20	25	30	35	40	45	50	60	70	75	80	90	100								
CXS□10	65	70	75	80	85	90	95	100	105	115	125	130	—	—	—	30	35	40	45	50	—	—	—	82	87	92	97	102	107	112	117	122	132	142	147	—	—	
CXS□15	70	75	80	85	90	95	100	105	110	120	130	135	140	150	160	25	35	45	45	55	—	—	—	89	94	99	104	109	114	119	124	129	139	149	154	159	169	179

Dual Rod Cylinder: Basic Type Series CXS

Dimensions: $\varnothing 20$, $\varnothing 25$, $\varnothing 32$

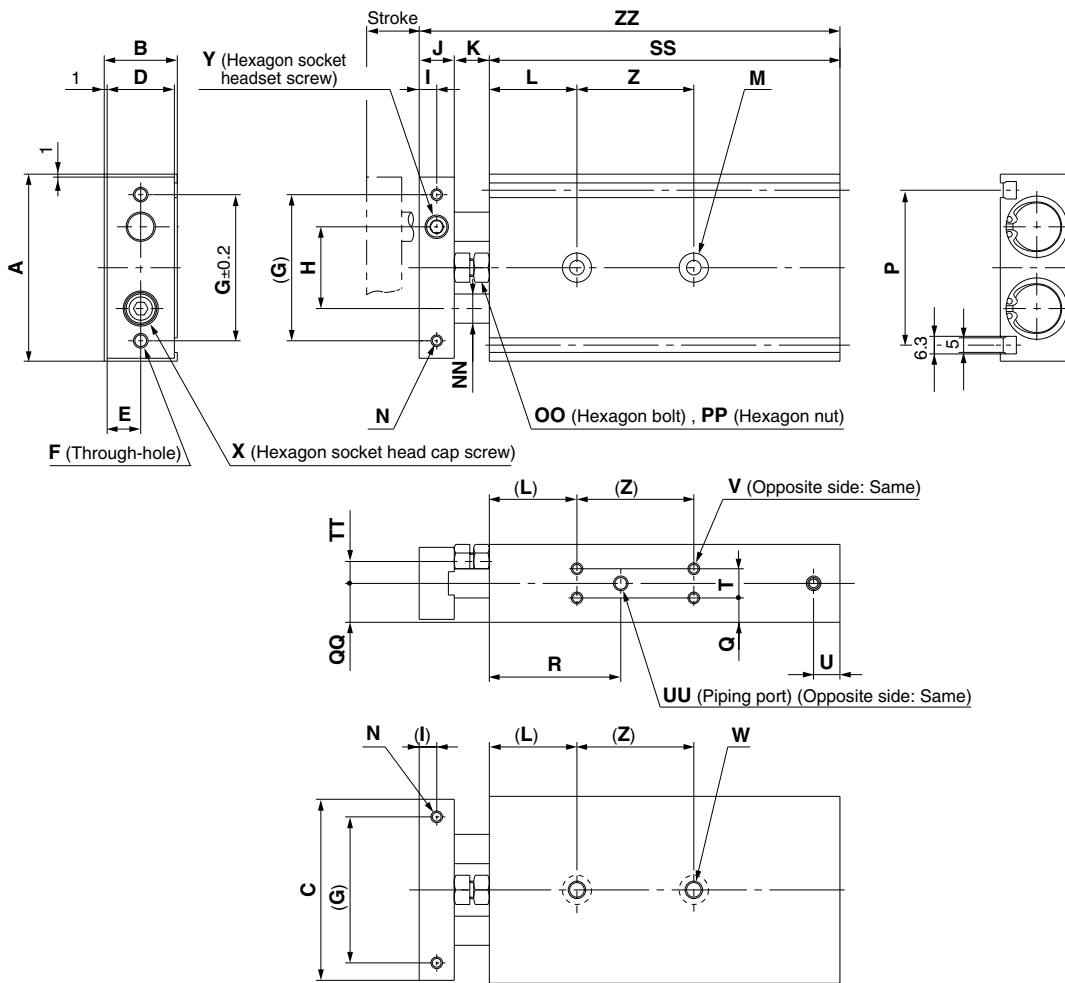

- MX
- MTS
- MY
- CY
- MG
- CX**
- D-
- X
- 20-
- Data

(mm)

Model	A	B	C	D	E	F	G	H	I	J	K	L	M	N	NN	OO	P
CXS \square 20	64	25	62	23	11.5	2-M5 x 0.8	50	28	6	12	12	30	2- $\varnothing 5.5$ through 2- $\varnothing 9.5$ counterbore depth 5.3	2-M4 x 0.7 thread depth 6	$\varnothing 10$	M6 x 1.0 x 18.5 ℓ	53
CXS \square 25	80	30	78	28	14	2-M6 x 1.0	60	35	6	12	12	30	2- $\varnothing 6.9$ through 2- $\varnothing 11$ counterbore depth 6.3	2-M5 x 0.8 thread depth 7.5	$\varnothing 12$	M6 x 1.0 x 18.5 ℓ	64
CXS \square 32	98	38	96	36	18	2-M6 x 1.0	75	44	8	16	14	30	2- $\varnothing 6.9$ through 2- $\varnothing 11$ counterbore depth 6.3	2-M5 x 0.8 thread depth 8	$\varnothing 16$	M8 x 1.25 x 23 ℓ	76

Model	PP	Q	QQ	R	T	TT	U	UU	V	W	X	Y
CXS \square 20	M6 x 1.0	7.75	12.5	45	9.5	6.5	8	4-M5 x 0.8 thread depth 4.5	8-M4 x 0.7 thread depth 5.5	2-M6 x 1.0 thread depth 10	M6 x 1.0 x 12 ℓ	M8 x 1.25 x 6 ℓ
CXS \square 25	M6 x 1.0	8.5	15	46	13	9	9	4-Rc 1/8 thread depth 6.5	8-M5 x 0.8 thread depth 7.5	2-M8 x 1.25 thread depth 12	M6 x 1.0 x 14 ℓ	M8 x 1.25 x 6 ℓ
CXS \square 32	M8 x 1.25	9	19	56	20	11.5	10	4-Rc 1/8 thread depth 6.5	8-M5 x 0.8 thread depth 7.5	2-M8 x 1.25 thread depth 12	M8 x 1.25 x 16 ℓ	M10 x 1.5 x 8 ℓ

Dimensions by Stroke

(mm)

Model	SS																Z				ZZ															
	10	16	20	25	30	35	40	45	50	60	70	75	80	90	100	10, 15, 20, 25	30, 35, 40, 45, 50	60, 70, 75, 80, 90, 100	10	15	20	25	30	35	40	45	50	60	70	75	80	90	100			
CXS \square 20	80	85	90	95	100	105	110	115	120	130	140	145	150	160	170	30	40	60	104	109	114	119	124	129	134	139	144	154	164	169	174	184	194			
CXS \square 25	82	87	92	97	102	107	112	117	122	132	142	147	152	162	172	30	40	60	106	111	116	121	126	131	136	141	146	156	166	171	176	186	196			
CXS \square 32	92	97	102	107	112	117	122	127	132	142	152	157	162	172	182	40	50	70	122	127	132	137	142	147	152	157	162	172	182	187	192	202	212			

Series CXS

Proper Auto Switch Mounting Position (Detection at stroke end)

Electrical entry direction: Inward

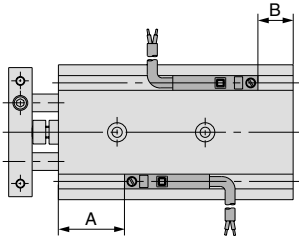

Electrical entry direction: Outward

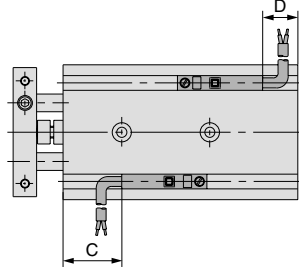

Bore size (mm)	A	B	D-Z7/Z8, D-Y7□W D-Y5□, D-Y7□		D-Y6□, D-Y7□V D-Y7□WV		D-Y7BAL	
			C	D	C	D	C	D
6	15.5	4.5	11.5 (10)	0.5 (-1)	13	2	5.5	-5.5
10	22.5	7.5	18.5 (17)	3.5 (2)	20	5	12.5	-2.5
15	30.5	4.5	26.5 (25)	0.5 (-1)	28	2	20.5	-5.5
20	38	7	34 (32.5)	3 (1.5)	36	4.5	28	-3
25	38	9	34 (32.5)	5 (3.5)	36	6.5	28	-1
32	48	9	44 (42.5)	5 (3.5)	46	6.5	38	-1

Lead wire entry is inward prior to shipment.
 Note 1) Negative figures in the table D indicate an auto switch is mounted inward from the edge of the cylinder body.
 Note 2) (): Denotes the dimensions of D-Z73.

Operating Range

Auto switch model	Bore size (mm)					
	6	10	15	20	25	32
D-Z7□/Z80	9	7	9	9	9	11
D-Y59□, D-Y69□ D-Y7P/Y7PV D-Y7□W/Y7□WV	3	3	3.5	3.5	4	4.5
D-Y7BAL	4	4	5.5	5.5	6	6

* Since this is a guideline including hysteresis, not meant to be guaranteed.
 (assuming approximately ±30% dispersion.)
 There may be the case it will vary substantially depending on an ambient environment.

Dimensions for Mounting of Auto Switch

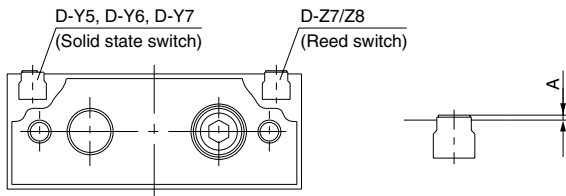

A Dimension

Auto switch model	Bore size (mm)					
	6	10	15	20	25	32
D-Y59A/Y7P/Y59B D-Y69A/Y7PV/Y69B D-Y7NWV/Y7PWV/Y7BWV D-Y7NW/Y7PW/Y7BW	0.7		0.2			
D-Y7BAL	6.5		6.0			
D-Z7, D-Z8	1.2		0.7			

Mounting of Auto Switch

When mounting and securing auto switches, they should be inserted into the cylinder's switch mounting rail from the direction shown in the drawing below. After setting in the mounting position, use a flat head watchmakers screwdriver to tighten the set screw that is included.

Note) When tightening an auto switch mounting screw, use a watchmakers' screwdriver with a handle of approximately 5 to 6 mm in diameter. Also, tighten with a torque of about 0.05 to 0.1 N·m. As a guide, turn about 90° past the point at which tightening can first be felt.

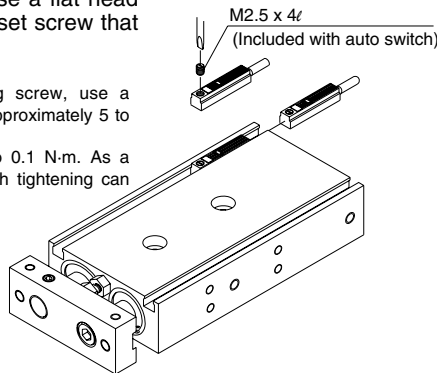

Caution

1. Avoid proximity to magnetic objects shown in the drawing below. If the clearance is less than the values noted in the table below, the auto switch may not function properly.

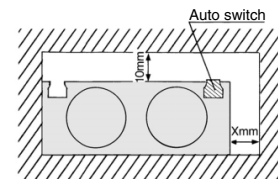

Bore size (mm)	X (mm)
6	0
10	0
15	10
20	10
25	0
32	0

Other than the applicable auto switches listed in "How to Order", the following auto switches can be mounted. For detailed specifications, refer to page 8-30-1.

Type	Model	Electrical entry (Fetching direction)	Features
Reed switch	D-Z80	Grommet (In-line)	Without indicator light

* Normally closed (NC = b contact), solid state switch (D-Y7G/Y7H type) are also available. For details, refer to page 8-30-32.