

## 4K SPI Bus Serial EEPROM

### Device Selection Table

Part Number	Vcc Range	Max. Clock Frequency	Temp. Ranges
25AA040	1.8-5.5V	1 MHz	I
25LC040	2.5-5.5V	2 MHz	I
25C040	4.5-5.5V	3 MHz	I,E

### Features:

- Low-power CMOS technology:
  - Write current: 3 mA, typical
  - Read current: 500  $\mu$ A, typical
  - Standby current: 500 nA, typical
- 512 x 8-bit organization
- 16 byte page
- Write cycle time: 5 ms max.
- Self-timed Erase and Write cycles
- Block write protection:
  - Protect none, 1/4, 1/2 or all of array
- Built-in write protection:
  - Power on/off data protection circuitry
  - Write enable latch
  - Write-protect pin
- Sequential read
- High reliability:
  - Endurance: 1M cycles
  - Data retention: > 200 years
  - ESD protection: > 4000V
- 8-pin PDIP, SOIC and TSSOP packages
- Temperature ranges supported:
  - Industrial (I): -40°C to +85°C
  - Automotive (E) (25C040): -40°C to +125°C

### Description:

The Microchip Technology Inc. 25AA040/25LC040/25C040 (25XX040\*) is a 4 Kbit serial Electrically Erasable PROM. The memory is accessed via a simple Serial Peripheral Interface (SPI) compatible serial bus. The bus signals required are a clock input (SCK) plus separate data in (SI) and data out (SO) lines. Access to the device is controlled through a Chip Select (CS) input.

\*25XX040 is used in this document as a generic part number for the 25AA040/25LC040/25C040 devices.

Communication to the device can be paused via the hold pin (HOLD). While the device is paused, transitions on its inputs will be ignored, with the exception of Chip Select, allowing the host to service higher priority interrupts. Also, write operations to the device can be disabled via the write-protect pin (WP).

### Package Types

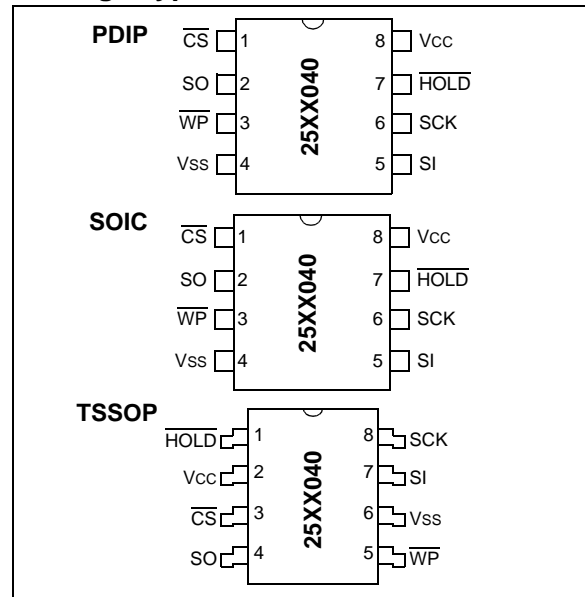

### Block Diagram

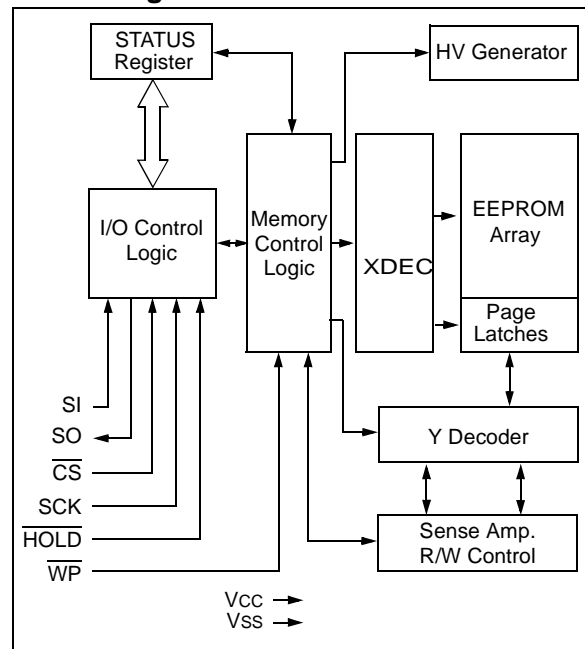

# 25AA040/25LC040/25C040

## 1.0 ELECTRICAL CHARACTERISTICS

### Absolute Maximum Ratings<sup>(†)</sup>

V <sub>CC</sub> .....	7.0V
All inputs and outputs w.r.t. V <sub>SS</sub> .....	-0.6V to V <sub>CC</sub> +1.0V
Storage temperature .....	-65°C to 150°C
Ambient temperature under bias.....	-65°C to 125°C
ESD protection on all pins.....	4 KV

† **NOTICE:** Stresses above those listed under “Absolute Maximum Ratings” may cause permanent damage to the device. This is a stress rating only and functional operation of the device at those or any other conditions above those indicated in the operational listings of this specification is not implied. Exposure to maximum rating conditions for an extended period of time may affect device reliability

**TABLE 1-1: DC CHARACTERISTICS**

DC CHARACTERISTICS			Industrial (I): T <sub>A</sub> = -40°C to +85°C V <sub>CC</sub> = 1.8V to 5.5V Automotive (E): T <sub>A</sub> = -40°C to +125°C V <sub>CC</sub> = 4.5V to 5.5V (25C040 only)			
Param. No.	Sym.	Characteristic	Min.	Max.	Units	Test Conditions
D001	V <sub>IH1</sub>	High-level input voltage	2.0	V <sub>CC</sub> +1	V	V <sub>CC</sub> ≥ 2.7V <b>(Note)</b>
D002	V <sub>IH2</sub>		0.7 V <sub>CC</sub>	V <sub>CC</sub> +1	V	V <sub>CC</sub> < 2.7V <b>(Note)</b>
D003	V <sub>IL1</sub>	Low-level input voltage	-0.3	0.8	V	V <sub>CC</sub> ≥ 2.7V <b>(Note)</b>
D004	V <sub>IL2</sub>		-0.3	0.3 V <sub>CC</sub>	V	V <sub>CC</sub> < 2.7V <b>(Note)</b>
D005	V <sub>OL</sub>	Low-level output voltage	—	0.4	V	I <sub>OL</sub> = 2.1 mA
D006	V <sub>OL</sub>		—	0.2	V	I <sub>OL</sub> = 1.0 mA, V <sub>CC</sub> < 2.5V
D007	V <sub>OH</sub>	High-level output voltage	V <sub>CC</sub> -0.5	—	V	I <sub>OH</sub> = -400 μA
D008	I <sub>LI</sub>	Input leakage current	—	±1	μA	$\overline{CS} = V_{CC}$ , V <sub>IN</sub> = V <sub>SS</sub> TO V <sub>CC</sub>
D009	I <sub>LO</sub>	Output leakage current	—	±1	μA	$\overline{CS} = V_{CC}$ , V <sub>OUT</sub> = V <sub>SS</sub> TO V <sub>CC</sub>
D010	C <sub>INT</sub>	Internal Capacitance (all inputs and outputs)	—	7	pF	T <sub>A</sub> = 25°C, CLK = 1.0 MHz, V <sub>CC</sub> = 5.0V <b>(Note)</b>
D011	I <sub>CC</sub> Read	Operating Current	—	1	mA	V <sub>CC</sub> = 5.5V; F <sub>CLK</sub> = 3.0 MHz; SO = Open
D012	I <sub>CC</sub> Write		—	500	μA	V <sub>CC</sub> = 2.5V; F <sub>CLK</sub> = 2.0 MHz; SO = Open
D013	I <sub>CCS</sub>	Standby Current	—	5	μA	$\overline{CS} = V_{CC} = 5.5V$ , Inputs tied to V <sub>CC</sub> or V <sub>SS</sub>
			—	1	μA	$\overline{CS} = V_{CC} = 2.5V$ , Inputs tied to V <sub>CC</sub> or V <sub>SS</sub>

**Note:** This parameter is periodically sampled and not 100% tested.

# 25AA040/25LC040/25C040

**TABLE 1-2: AC CHARACTERISTICS**

AC CHARACTERISTICS			Industrial (I): TA = -40°C to +85°C		VCC = 1.8V to 5.5V	
			Automotive (E): TA = -40°C to +125°C		VCC = 4.5V to 5.5V (25C040 only)	
Param No.	Sym.	Characteristic	Min.	Max.	Units	Test Conditions
1	FCLK	Clock Frequency	—	3	MHz	VCC = 4.5V to 5.5V
			—	2	MHz	VCC = 2.5V to 4.5V
			—	1	MHz	VCC = 1.8V to 2.5V
2	Tcss	CS Setup Time	100	—	ns	VCC = 4.5V to 5.5V
			250	—	ns	VCC = 2.5V to 4.5V
			500	—	ns	VCC = 1.8V to 2.5V
3	Tcsh	CS Hold Time	150	—	ns	VCC = 4.5V to 5.5V
			250	—	ns	VCC = 2.5V to 4.5V
			475	—	ns	VCC = 1.8V to 2.5V
4	TcSD	CS Disable Time	500	—	ns	—
5	TSU	Data Setup Time	30	—	ns	VCC = 4.5V to 5.5V
			50	—	ns	VCC = 2.5V to 4.5V
			50	—	ns	VCC = 1.8V to 2.5V
6	THD	Data Hold Time	50	—	ns	VCC = 4.5V to 5.5V
			100	—	ns	VCC = 2.5V to 4.5V
			100	—	ns	VCC = 1.8V to 2.5V
7	TR	CLK Rise Time	—	2	µs	(Note 1)
8	TF	CLK Fall Time	—	2	µs	(Note 1)
9	THI	Clock High Time	150	—	ns	VCC = 4.5V to 5.5V
			230	—	ns	VCC = 2.5V to 4.5V
			475	—	ns	VCC = 1.8V to 2.5V
10	TLO	Clock Low Time	150	—	ns	VCC = 4.5V to 5.5V
			230	—	ns	VCC = 2.5V to 4.5V
			475	—	ns	VCC = 1.8V to 2.5V
11	TCLD	Clock Delay Time	50	—	ns	—
12	TCLE	Clock Enable Time	50	—	ns	—
13	TV	Output Valid from Clock Low	—	150	ns	VCC = 4.5V to 5.5V
			—	230	ns	VCC = 2.5V to 4.5V
			—	475	ns	VCC = 1.8V to 2.5V
14	THO	Output Hold Time	0	—	ns	(Note 1)
15	TDis	Output Disable Time	—	200	ns	VCC = 4.5V to 5.5V (Note 1)
			—	250	ns	VCC = 2.5V to 4.5V (Note 1)
			—	500	ns	VCC = 1.8V to 2.5V (Note 1)
16	THS	HOLD Setup Time	100	—	ns	VCC = 4.5V to 5.5V
			100	—	ns	VCC = 2.5V to 4.5V
			200	—	ns	VCC = 1.8V to 2.5V
17	THH	HOLD Hold Time	100	—	ns	VCC = 4.5V to 5.5V
			100	—	ns	VCC = 2.5V to 4.5V
			200	—	ns	VCC = 1.8V to 2.5V
18	THZ	HOLD Low to Output High-Z	100	—	ns	VCC = 4.5V to 5.5V (Note 1)
			150	—	ns	VCC = 2.5V to 4.5V (Note 1)
			200	—	ns	VCC = 1.8V to 2.5V (Note 1)
19	THV	HOLD High to Output Valid	100	—	ns	VCC = 4.5V to 5.5V
			150	—	ns	VCC = 2.5V to 4.5V
			200	—	ns	VCC = 1.8V to 2.5V
20	TWC	Internal Write Cycle Time	—	5	ms	—
21	—	Endurance	1M	—	E/W Cycles	(Note 2)

**Note 1:** This parameter is periodically sampled and not 100% tested.

**Note 2:** This parameter is not tested but ensured by characterization. For endurance estimates in a specific application, please consult the Total Endurance™ Model which can be obtained from our web site

# 25AA040/25LC040/25C040

8-Lead Plastic Small Outline (SN) – Narrow, 150 mil (SOIC)

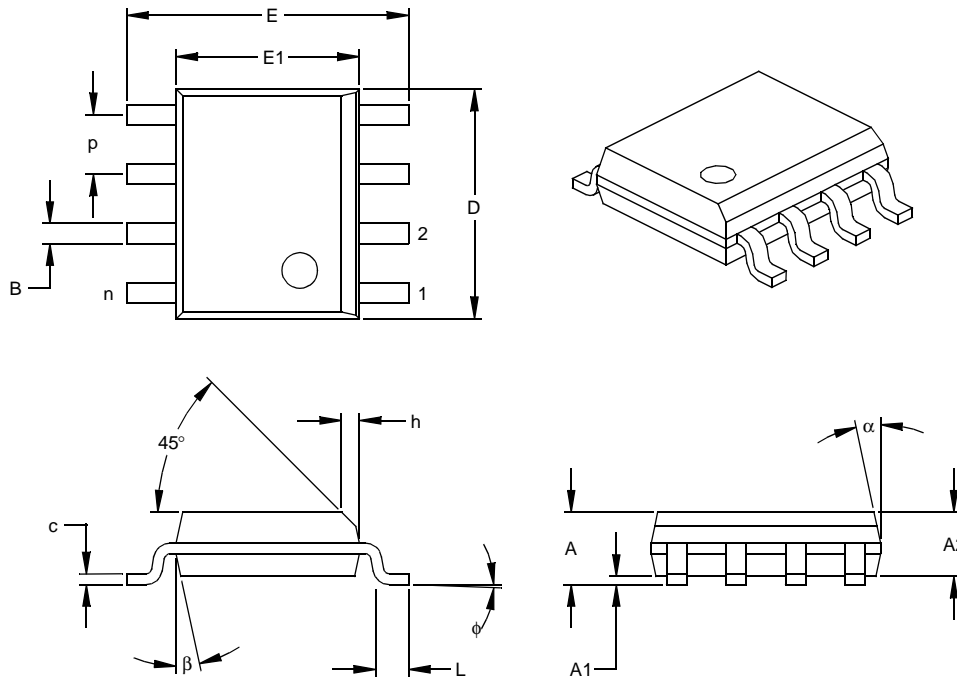

Units		INCHES*			MILLIMETERS		
Dimension Limits		MIN	NOM	MAX	MIN	NOM	MAX
Number of Pins	n	8			8		
Pitch	p		.050			1.27	
Overall Height	A	.053	.061	.069	1.35	1.55	1.75
Molded Package Thickness	A2	.052	.056	.061	1.32	1.42	1.55
Standoff §	A1	.004	.007	.010	0.10	0.18	0.25
Overall Width	E	.228	.237	.244	5.79	6.02	6.20
Molded Package Width	E1	.146	.154	.157	3.71	3.91	3.99
Overall Length	D	.189	.193	.197	4.80	4.90	5.00
Chamfer Distance	h	.010	.015	.020	0.25	0.38	0.51
Foot Length	L	.019	.025	.030	0.48	0.62	0.76
Foot Angle	φ	0	4	8	0	4	8
Lead Thickness	c	.008	.009	.010	0.20	0.23	0.25
Lead Width	B	.013	.017	.020	0.33	0.42	0.51
Mold Draft Angle Top	α	0	12	15	0	12	15
Mold Draft Angle Bottom	β	0	12	15	0	12	15

\* Controlling Parameter

§ Significant Characteristic

**Notes:**

Dimensions D and E1 do not include mold flash or protrusions. Mold flash or protrusions shall not exceed .010" (0.254mm) per side.

JEDEC Equivalent: MS-012

Drawing No. C04-057

# 25AA040/25LC040/25C040

## PRODUCT IDENTIFICATION SYSTEM

To order or obtain information, e.g., on pricing or delivery, refer to the factory or the listed sales office.

<u>PART NO.</u>	<u>X</u>	<u>XX</u>	<u>XXX</u>
Device	Temperature Range	Package	Pattern
<b>Device:</b>			
25AA040:	4096-bit 1.8V SPI Serial EEPROM		
25AA040T:	4096-bit 1.8V SPI Serial EEPROM (Tape and Reel)		
25XX040X:	4096-bit 1.8V SPI Serial EEPROM in alternate pinout (ST only)		
25AA040XT:	4096-bit 1.8V SPI Serial EEPROM in alternate pinout Tape and Reel (ST only)		
25LC040:	4096-bit 2.5V SPI Serial EEPROM		
25LC040T:	4096-bit 2.5V SPI Serial EEPROM (Tape and Reel)		
25LC040X:	4096-bit 2.5V SPI Serial EEPROM in alternate pinout (ST only)		
25LC040XT:	4096-bit 2.5V SPI Serial EEPROM in alternate pinout Tape and Reel (ST only)		
25C040:	4096-bit 5.0V SPI Serial EEPROM		
25C040T:	4096-bit 5.0V SPI Serial EEPROM (Tape and Reel)		
25C040X:	4096-bit 5.0V SPI Serial EEPROM in alternate pinout (ST only)		
25C040XT:	4096-bit 5.0V SPI Serial EEPROM in alternate pinout Tape and Reel (ST only)		
<b>Temperature Range:</b>			
I	=	-40 °C to +85 °C	
E	=	-40 °C to +125 °C	
<b>Package:</b>			
P	=	Plastic DIP (300 mil body), 8-lead	
SN	=	Plastic SOIC (150 mil body), 8-lead	
ST	=	Plastic TSSOP (4.4 mm body), 8-lead	
<b>Examples:</b>			
a)	25AA040-I/P:	Industrial Temp., PDIP package	
b)	25AA040-I/SN:	Industrial Temp., SOIC package	
c)	25AA040T-I/SN:	Tape and Reel, Industrial Temp., SOIC package	
d)	25AA040X-I/ST:	Alternate Pinout, Industrial Temp., TSSOP package	
e)	25AA040XT-I/ST:	Alternate Pinout, Tape and Reel, Industrial Temp., TSSOP package	
f)	25LC040-I/P:	Industrial Temp., PDIP package	
g)	25LC040-I/SN:	Industrial Temp., SOIC package	
h)	25LC040T-I/SN:	Tape and Reel, Industrial Temp., SOIC package	
i)	25LC040X-I/ST:	Alternate Pinout, Industrial Temp., TSSOP package	
j)	25LC040XT-I/ST:	Alternate Pinout, Tape and Reel, Industrial Temp., TSSOP package	
k)	25C040-I/P:	Industrial Temp., PDIP package	
l)	25C040-I/SN:	Industrial Temp., SOIC package	
m)	25C040T-I/SN:	Tape and Reel, Industrial Temp., SOIC package	
n)	25C040X-I/ST:	Alternate Pinout, Industrial Temp., TSSOP package	
o)	25C040XT-I/ST:	Alternate Pinout, Tape and Reel, Industrial Temp., TSSOP package	
p)	25C040-E/P:	Extended Temp., PDIP package	
q)	25C040-E/SN:	Extended Temp., SOIC package	
r)	25C040T-E/SN:	Tape and Reel, Extended Temp., SOIC package	
s)	25C040X-E/ST:	Alternate Pinout, Extended Temp., TSSOP package	
t)	25C040XT-E/ST:	Alternate Pinout, Tape and Reel, Extended Temp., TSSOP package	