

Screw Connectors for Printed Circuit Boards

TYPE 158-A-111 /-211

0.4 in. spacing - 1 to 12 poles

[Distributor Stock Check](#)

Series	Download PDF	3D Model	Can plug with	How to order	Color specifications	Print
--------	--------------	----------	---------------	--------------	----------------------	-------



158-A-111



158-A-211

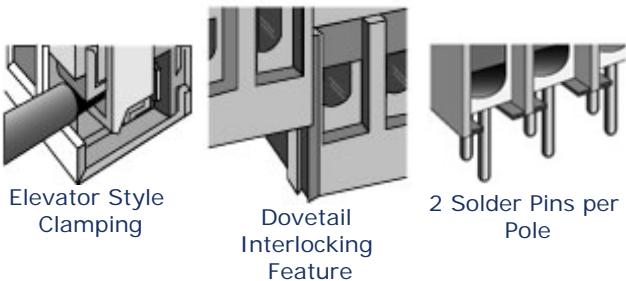

Elevator Style Clamping

Dovetail Interlocking Feature

2 Solder Pins per Pole

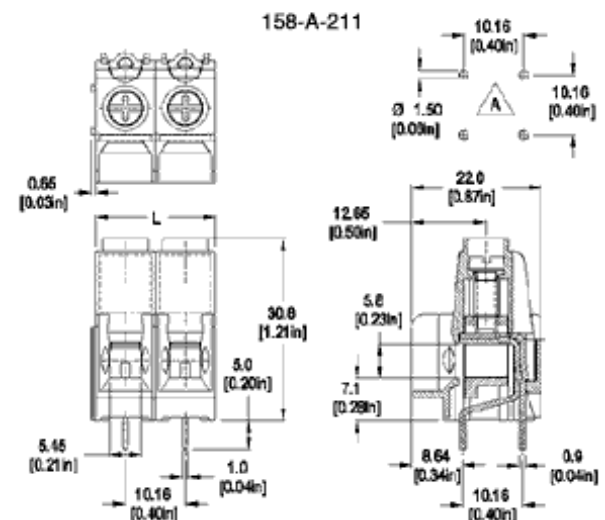
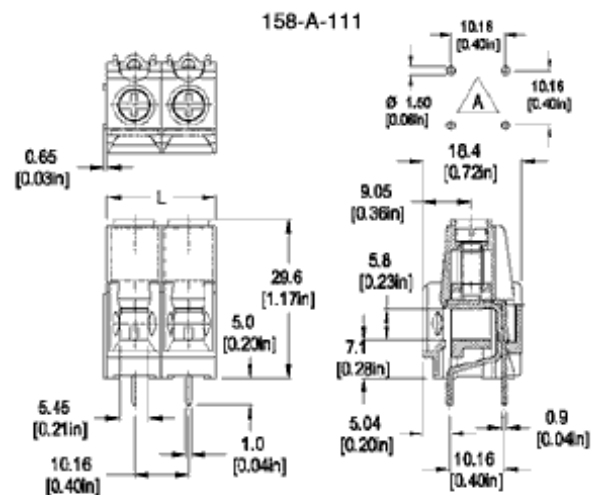

Dimensions: mm (in.)

Length of Connector (L)

L = No. of Poles x Center to Center Spacing
(A) PBC Hole layout

When locating connector, allow 0.5 mm clearance around it for process-induced variations.

Approval Information



RoHS WEEE Pb
free compliant

UL File No.E69841

Rating	Current(A)	Voltage(V)	Application group	AWG
UL	60	300	B, C	20-6
UL	10	300	D	20-6
CSA				

* UL Group D: voltage: 300V current: 10A AWG: 20-6

Description

The 158-A series is built in two versions. 158-A-111 is a 18.4 mm profile version and 158-A-211 is a 22 mm profile version. The extended barrier walls on the front of 158-A-211 add an extra finger protection. Universal Pozidriv screws enhance torque. Suitable for pozidriv, phillips, blade and robertson screw drivers. Performance varies depending on screw driver tip type, size and wear.

- power connector
- Dovetail version
- Wire entrance parallel to PC Board
- With test holes
- 2 PCB Pins per pole
- Elevator-style clamping mechanism
- 2 PCB pins per pole confer equal current flow distribution

Technical Data

Center to Center Spacing: 10.16 mm (0.400 in.)

Nominal Cross Section:

16 mm² (24793 mil²)

Wire Stripping Length: 10.5 mm (0.410 in.)

Recommended Hole Diameter in PC Board:

1.5 mm (0.60 in.)

Application

The 158-A and 159-A series address the field application of power interconnect: power supply units for industrial controllers, power controllers, power converters, motor controls, AC drives, and spa controls.

Screw Tightening Torque:

UL: 11.5 lbf·in

Rated Impulse Withstand Voltage: 8 Kv

Material

Molding: Rigid polyamide, self extinguishing UL 94, V-0, color grey

Temperature limits:

Short Time: 140°C (284°F)

Continuous: RTI 120°C (248°F)

Low Limit: -40°C (-40°F)

Comparative Tracking Index: CTI > 600

Oxygen Index Rating: 33%

Terminal Body: Nickel plated copper alloy

Screw: M4, Cross slotted head (Pozidriv, Z2 type), zinc plated blue passivated, steel substrate

Solder Pin: 0.9 x 1.0 mm (0.035 x 0.039 in.), Tin plated copper alloy (E-CU)

Top of page

How to order

Item 158-A-111 /-211

Options

CN: Consecutive Numbering (hot stamped numbers)

SM: Special Marking (please provide sketch)

Request sample

Request quote

Quantity

Accessories

EXTENDED BARRIER WALLS:
Without: 1 With: 2

POLES:
01 to 12

158-A-

11 /

Add to shopping cart