

DC Series Tubeaxial Cooling Fans Model No. D47T15

4.69" Sq. x 1.50"
(119 mm Sq. x 38 mm)
97-108 CFM
(45.8-51.0 L/Sec.)



Features

- Solid-state brushless motor design provides:
 - Auto restart
 - Low input power
 - Lower operating voltages
- Precision ball bearing system provides:
 - Longer life
 - Higher temperature extremes
 - Lower noise over time
 - Maximum shock and vibration resistance
- Designed to meet the rigid standards of UL, CSA, VDE, and CE.

Accessories:

- Finger guards
- Filters

General Specifications

Frame: Reinforced polybutylene plastic (UL94V-0 flame retardant)

Impeller: Reinforced polybutylene plastic (UL94V-0 rating)

Bearings: Precision, life-lubricated ball bearings

Insulation: Class A integral ground system rated @ 248°F (120°C)

Weight: 9.2 ozs. (260 grams)

Operating Temperature Range: 14° to 158°F (-10° to 70°C)

Insulation Resistance: 10 megohms minimum @ 500 VDC

Dielectric Strength: 500 VAC for 60 seconds

Safety Protection: Electronic locked rotor protected; polarity protected

Life Expectancy: 75,000 hours minimum @ 77°F (25°C)

Options: (Consult Factory)

- Tachometer output
- Locked rotor sensor output (Not available on 48 VDC)

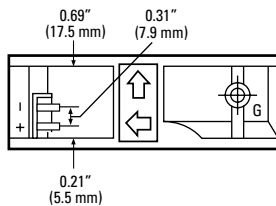

Terminals

- 2 Solder Terminals
- Centers: .312" (7.92 mm)
- Thickness: .02" (.51 mm)
- Width: .120" (3.05 mm)
- Length: .31" (7.8 mm)

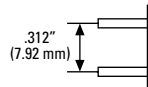

RED LEAD IS POSITIVE (+)
BLACK LEAD IS NEGATIVE (-)
WHITE LEAD IS TACHOMETER/SENSOR

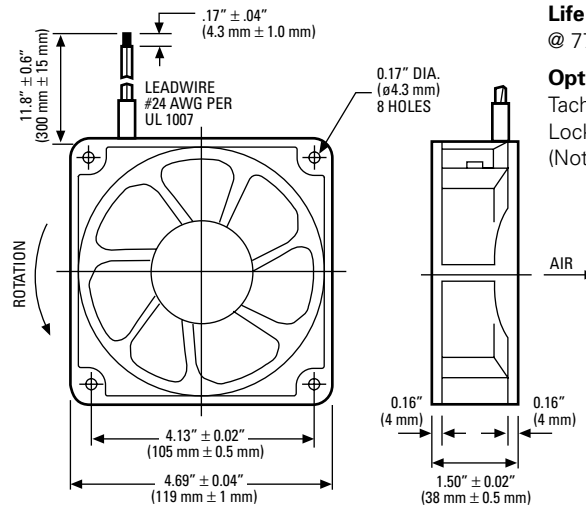

Globe Motors Part Number	Nominal Voltage VDC	Voltage Operating Range VDC	Watts	Line Amps	RPM	Acoustic Noise dBA	Airflow (Min.)	
							CFM	Liters per Second
D47-B15A-04T2-100	12	6.0 / 13.8	4.80	0.40	2650	41	97	45.8
D47-B15A-04W2-100	12	6.0 / 13.8	4.80	0.40	2650	41	97	45.8
D47-B15A-04T3-100	12	6.0 / 13.8	6.60	0.55	2950	43	108	51.0
D47-B15A-04W3-100	12	6.0 / 13.8	6.60	0.55	2950	43	108	51.0
D47-B15A-04T4-100	12	6.0 / 13.8	8.40	0.70	3200	46	118	55.7
D47-B15A-04W4-100	12	6.0 / 13.8	8.40	0.70	3200	46	118	55.7
D47-B15A-05T2-100	24	10.0 / 27.6	5.04	0.21	2650	41	97	45.8
D47-B15A-05W2-100	24	10.0 / 27.6	5.04	0.21	2650	41	97	45.8
D47-B15A-05T3-100	24	10.0 / 27.6	7.44	0.31	2950	43	108	51.0
D47-B15A-05W3-100	24	10.0 / 27.6	7.44	0.31	2950	43	108	51.0
D47-B15A-05T4-100	24	10.0 / 27.6	8.40	0.35	3200	46	118	55.7
D47-B15A-05W4-100	24	10.0 / 27.6	8.40	0.35	3200	46	118	55.7
D47-B15A-07T3-100	48	25.0 / 55.2	7.68	0.16	2950	43	108	51.0
D47-B15A-07W3-100	48	25.0 / 55.2	7.68	0.16	2950	43	108	51.0

*Note: For tachometer output models, substitute "B" in part number. Part Number D47-B15"A"-04W2-100 would change to D47-B15"B"-04W2-100. Minimum order quantity may apply.
For locked rotor sensor output models, substitute "C" in part number. Part Number D47-B15"A"-04W2-100 would change to D47-B15"C"-04W2-100. Minimum order quantity may apply.

Installation Guide

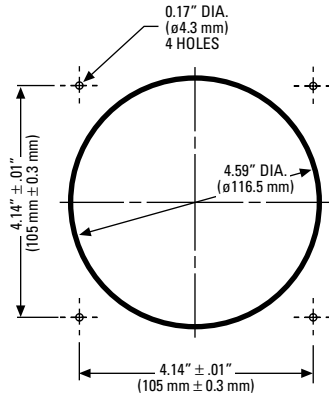

Performance at Sea Level

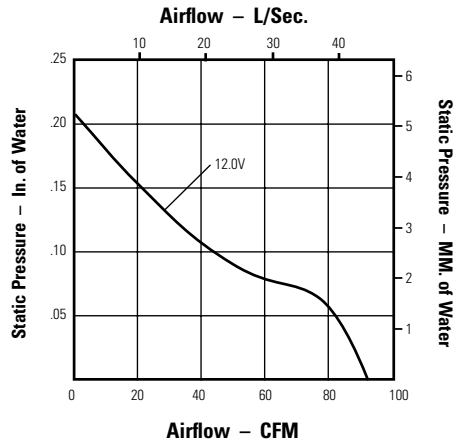

D47-B15A-04W2-100

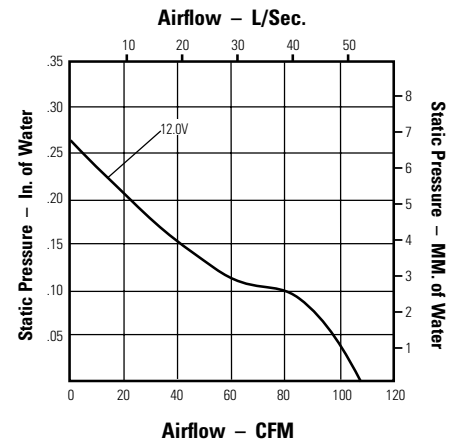

D47-B15A-04W3-100

Approvals



UL File No.
E105397



CSA File No.
72877



VDE File No.
17074-2611-0701

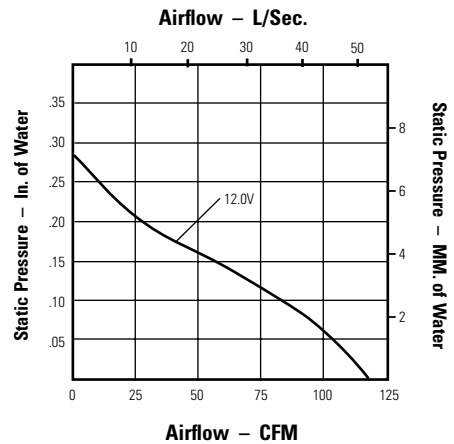

D47-B15A-04W4-100

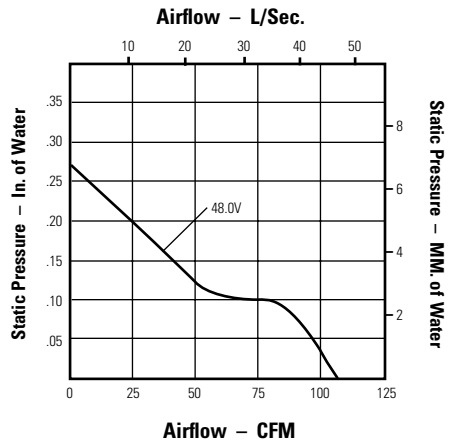

D47-B15A-07W3-100

Tachometer Output (Open Collector Circuit)

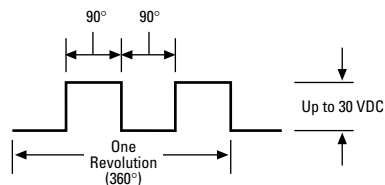

Locked Rotor Output (Open Collector Circuit)

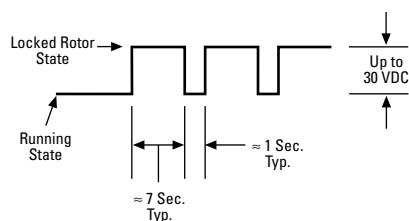

All operating specifications measured at nominal operating voltage, free air at sea level

24 volt performance is identical to 12 volt fan performance

NOTES: