

AND671GST/GST-LED

1 Line x 16 Characters

Intelligent Character Display

The AND671GST/GST-LED devices are compact, LCD modules that have an on-board LCD controller and driver circuit. These devices can display 160 characters (numerals, letters, symbols and Kana letters), as well as eight custom characters.

Features

• RoHS Compliant

- AND671GST: Super Twist Technology
- AND671GST-LED: STN with LED backlight
- Low voltage, +5V single power supply
- Built-in controller (KS0066 or equivalent)
- 1/16 Duty Cycle
- 4.2 V LED Forward Voltage

Dot Matrix Dimensions

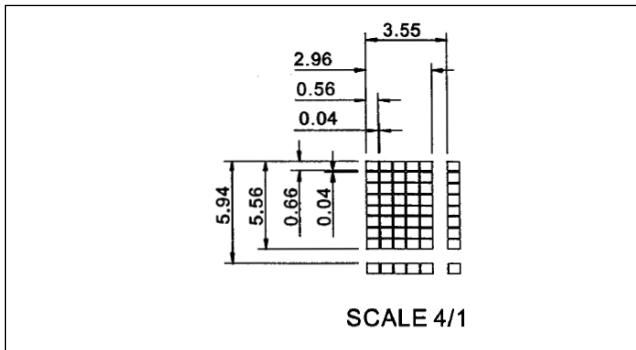

Mechanical Characteristics

Item	Specification	Unit
Outline Dimensions	80 (W) x 36 (H) x 8.8 (12.7LED) (D)	mm
Character Size	2.96 (W) x 5.56 (H)	mm
Character Pitch	3.55 (W) x 5.94 (H)	mm
Viewing Area	65.0 (W) x 16.0 (H)	mm
Dot Size	0.55 (W) x 0.66 (H)	mm
Dot Pitch	0.60 (W) x 0.70 (H)	mm

Electrical Characteristics (TA = 25°C)

Item	Symbol	Condition	Min.	Typ.	Max.	Unit
LCD Operating Voltage	$V_{DD}-V_O$	T=0°C	-	4.8	-	V
		T=25°C	-	4.5	-	V
		T=50°C	-	4.2	-	V
Supply Voltage	$V_{DD}-V_{SS}$	-	4.7	5	5.3	V
Supply Current	I_{DD}	-	-	2	4	mA
Input Voltage High Level	V_{IH}	-	2.2	-	V_{DD}	V
Input Voltage Low Level	V_{IL}	-	0	-	0.6	V
Output Voltage High Level	V_{OH}	-	2.4	-	-	V
Output Voltage Low Level	V_{OL}	-	-	-	0.4	V

Optical Characteristics (TA = 25°C, $\phi = 0^\circ$, $\theta = 0^\circ$)

Item	Symbol	Min.	Typ.	Max.	Unit
Viewing Angle	ϕ	-	50	-	degree
Contrast	K	-	6.0	-	-
Turn On	T_{on}	-	200	400	ms
Turn Off	T_{off}	-	250	400	ms

Product specifications contained herein may be changed without prior notice.

It is therefore advisable to contact Purdy Electronics before proceeding with the design of equipment incorporating this product.

Purdy Electronics Corporation • 720 Palomar Avenue • Sunnyvale, CA 94085



AND671GST/GST-LED Intelligent Character Display

Connector Pin Assignment

Pin No.	Signal	Function
1	V _{SS}	0V
2	V _{DD}	5V
3	V _O	Contrast Adj.
4	RS	Register Select
5	R/W	Read/Write
6	E	Enable Signal
7	DB0	Data Bit 0
8	DB1	Data Bit 1
9	DB2	Data Bit 2
10	DB3	Data Bit 3
11	DB4	Data Bit 4
12	DB5	Data Bit 5
13	DB6	Data Bit 6
14	DB7	Data Bit 7
15	A	LED Power
16	K	LED Power

Block Diagram

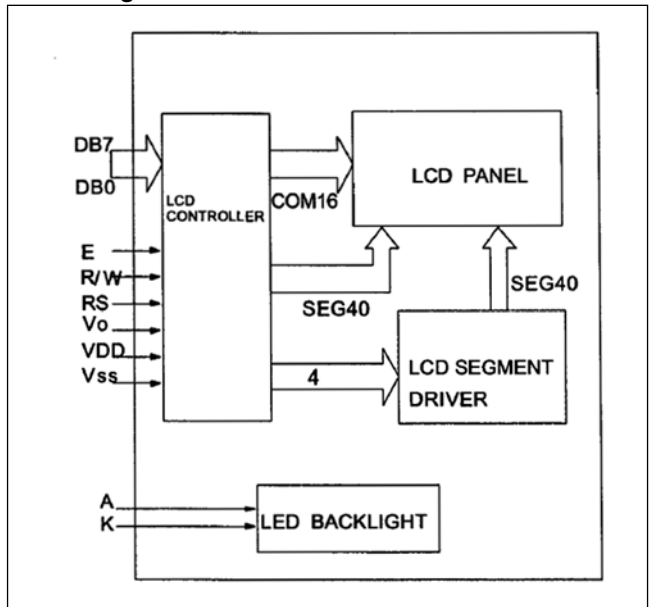

Dimensional Outline

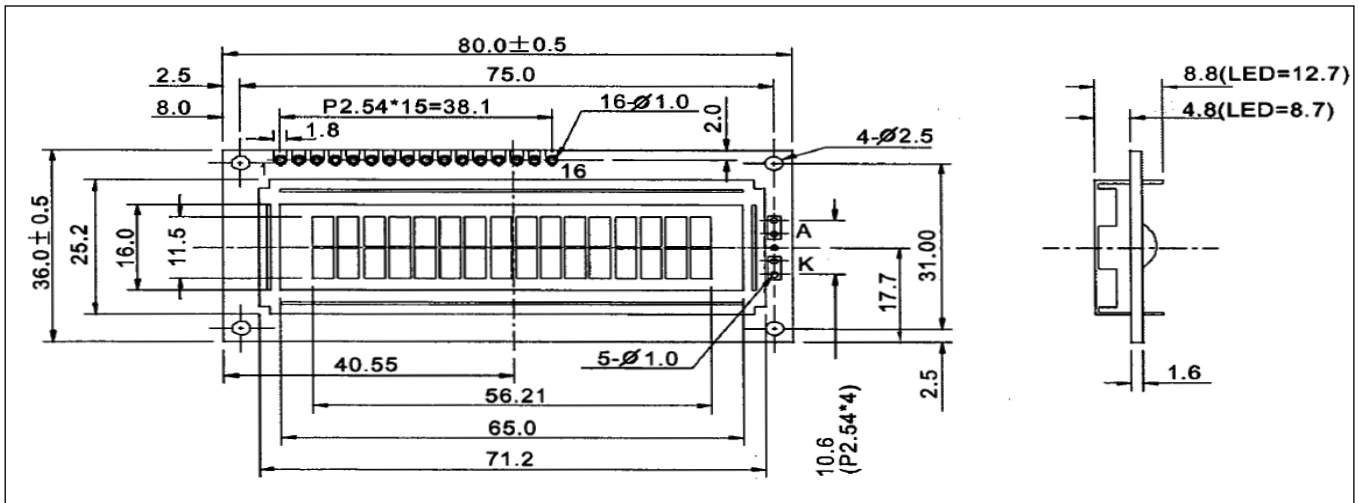



AND671GST/GST-LED Intelligent Character Display

Absolute Maximum Ratings

Item	Symbol	Condition	Standard Value			Unit	Applicable Terminal
			Min.	Typ.	Max.		
Power Supply Voltage	V_{DD}		4.5	5	5.5	V	V_{DD}
Input "H" Level Voltage	V_{IH1}		2.2	-	V_{DD}	V	RS, R/W, E, DB ₀ ~ DB ₇
Input "L" Level Voltage	V_{IL1}		-0.3	-	0.6	V	
Output "H" Level Voltage	V_{OH}	$I_{OH} = 0.205 \text{ mA}$	2.4	-	-	V	DB ₀ ~ DB
Output "L" Level Voltage	V_{OL}	$I_{OL} = 1.2 \text{ mA}$	-	-	0.4	V	
Input Leakage Current	V_{LI}	$V_{IN} = 0 - V_{DD}$	-1	-	1	μA	RS, R/W, E, DB ₀ ~ DB ₇
Power Supply Current	I_{DD}	$V_{DD} = 5\text{V}$	-	-	3	mA	V_{DD}
LCD Power Supply Voltage	V_{LCD}	$V_{DD} - V_0$	3	-	-	V	V_0

AC Characteristics

Item	Symbol	Min.	Max.	Unit
Enable Cycle Time	t_{CVCE}	500	-	ns
Enable Pulse Width	"High Level" P_{WEH}	230	-	ns
Enable Rise/Fall Time	t_{ER}, t_{EF}	-	20	ns
Address Set-up Time	RS, R/W to E t_{AS}	40	-	ns
Address Hold Time	t_{AH}	10	-	ns
Data Set-up Time	t_{DSW}	80	-	ns
Data Delay Time	t_{DDR}	-	160	ns
Data Hold Time (Writing)	t_H	10	-	ns
Data Hold Time (Reading)	t_{DHR}	5	-	ns
Clock Oscillation Frequency	f_{OSC}	270 (Typ.)		KHz

Timing Characteristics

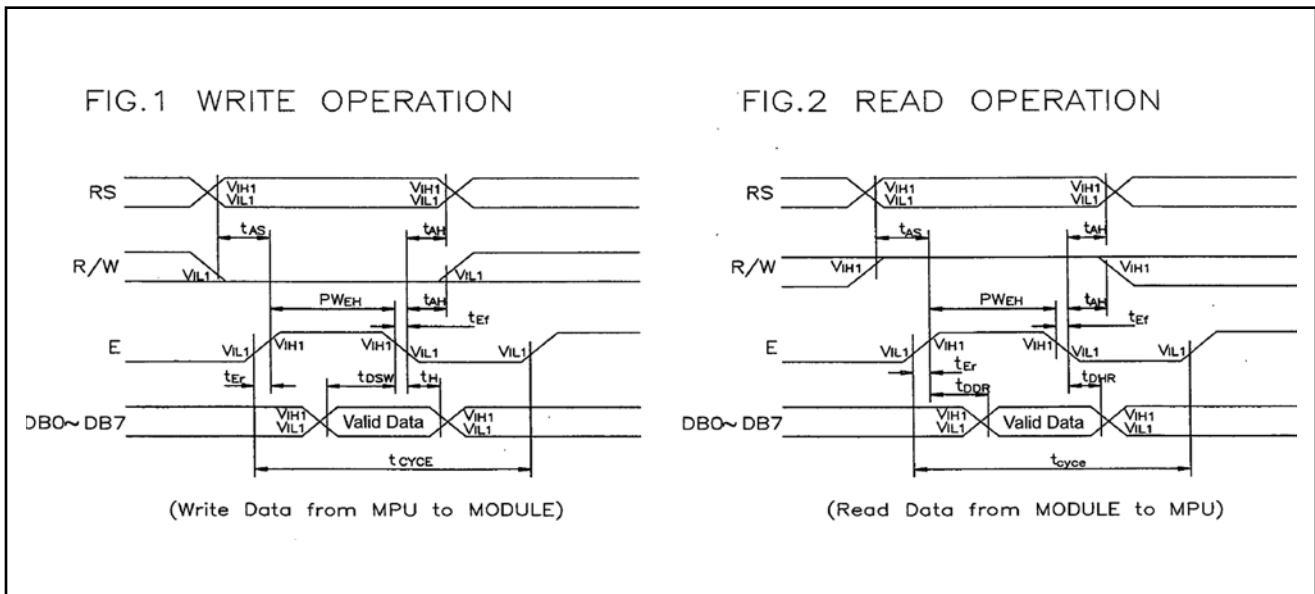



AND671GST/GST-LED Intelligent Character Display

Display Commands

Instruction	Code										Description
	RS	R/W	DB7	DB6	DB5	DB4	DB3	DB2	DB1	DB0	
1: Clear Display	0	0	0	0	0	0	0	0	0	1	Clears entire display & sets DD RAM address 0 in address counter.
2: Return Home	0	0	0	0	0	0	0	0	1	*	Sets DD RAM address 0 in address counter. Also returns display from being shifted to original position. DDRAM contents remain unchanged.
3: Entry Mode Set	0	0	0	0	0	0	0	1	I/D	S	I/D = 1: Increment I/D = 0: Decrement S=1: Accompanies display shift
4: Display On/Off	0	0	0	0	0	0	1	D	C	B	I/D = 1/0: Display on/off I/D = 0/1: Cursor on/off S=1: Blink of cursor
5: Cursor/Display Shift	0	0	0	0	0	1	S/C	R/L	*	*	S/C=1: Display shift S/C = 0: Cursor move R/L = 0: Shift to left R/L = 1: Shift to right
6: Function Set	0	0	0	0	1	DL	N	F	*	*	DL = 1: 8 bits, DL = 0: 4 bits N=1: 2 lines, N=0: 1 line F=1: 5*10 dots, F=0: 5*8 dots
7: Set CG RAM Address	0	0	0	1	A_{CG}					A_{CG} : CG RAM Address	
8: Set DD RAM Address	0	0	1	A_{DD}					A_{DD} : DDRAM address corresponds to cursor address		
9: Read busy flag/ address counter	0	1	BF	A_C					BF=1: Busy, BF=0: Not busy A_C : Address counter used for both of CG & DDRAM address		
10: Write data	1	0	Write Data					Write data to CG or DD RAM			
11: Read data	1	1	Read Data					Read data from CG or DD RAM			

† Execution Time (Et) of Instruction: (Under condition of or $f_{OSC} = 270$ KHz)
 1 & 2: Et = 1.52 ms
 3 ~ 11: Et = 37 μ s
 † ***: Either 0 or 1

Connecting Block Diagram

