

FEATURES/BENEFITS

- Latest generation MOSFET technology
- Ultra low on-state resistance
- Innovative isolated driver ensures fast power transistor turn on and off and thus low power transient
- Ultra low output leakage current
- Low control current consumption
- Triggered control input to avoid linear control risks
- Low conducted and radiated disturbances



Part Number	Description
S75DC150	150A, 42 Vdc Solid-State Relay

Part Number Explanation

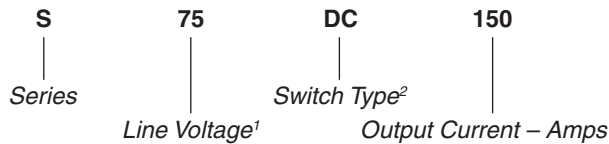

NOTES
1) Line Voltage (peak): 42 = 42 Vdc
2) Switch Type: DC = DC

ELECTRICAL SPECIFICATIONS

(+25°C ambient temperature unless otherwise specified)

INPUT (CONTROL) SPECIFICATIONS

	Min	Max	Units
Control Range	4.5	32	Vdc
Input Current Range	25	42	mAdc
Typical Turn-On Voltage	4.3		Vdc
Must Turn-Off Voltage	1		Vdc
Reverse Voltage		32	Vdc
Reverse Leakage Current		100	µA

CONTROL CHARACTERISTIC

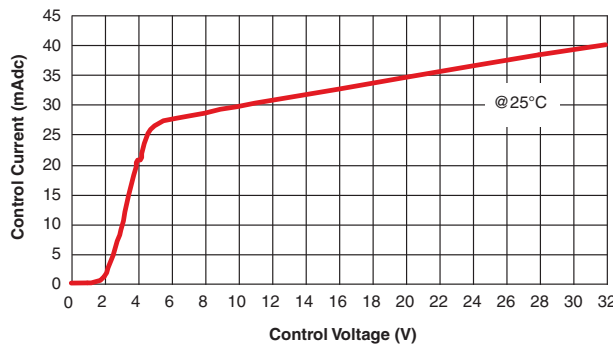
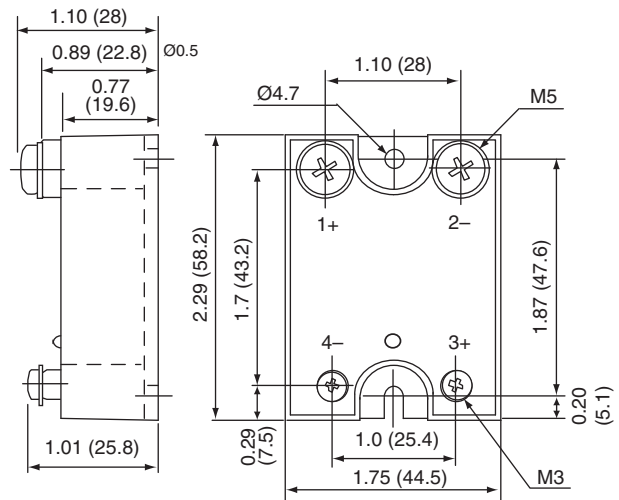

Figure 2

MECHANICAL SPECIFICATION



Tolerances: Ø0.3
Dimensions in inches (mm)
Weight: 3.52 oz. (100g)

Figure 1

BLOCK DIAGRAM

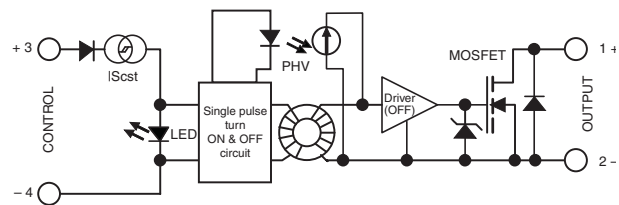

Figure 3

ELECTRICAL SPECIFICATIONS
(+25°C ambient temperature unless otherwise specified)

OUTPUT (LOAD) SPECIFICATIONS

	Min	Max	Units
Operating Range	Depends on protection clamping voltage		
Peak Voltage		75	V _{peak}
Reverse Voltage (Internal Diode)	0.92		V
Maximum Repetitive Avalanche Current	125		A
Maximum Single Pulse Avalanche Energy		1970	mJ
Maximum Repetitive Pulse Avalanche Energy		200	mJ
Maximum Nominal Currents (Resistive)	150		A
Leakage Current		500	μA _{dc}
On-State Resistance		2.25	mΩ
Output Capacitance (Typical)	1.5		nF
Junction-Case Thermal Resistance		0.62	°C/W
Built-In Heat Sink Thermal Resistance (Vertically Mounted)		10	°C/W
Heat Sink Thermal Time Constant		10	min
Control Inputs/Power Outputs Insulation Voltage		4	kV
Turn-On Time		10	μs
Turn-On Delay		600	μs
Turn-Off Time		10	μs
Turn-Off Delay		100	μs
On-Off Frequency		700	Hz

HIGH SIDE WIRING DIAGRAM
(Load Connected to “-”)

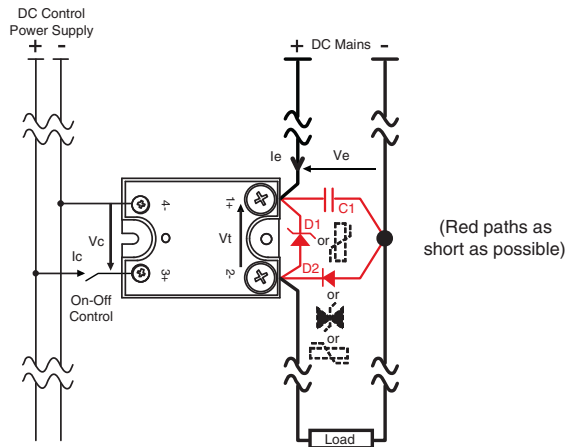

Figure 4

LOW SIDE WIRING DIAGRAM
(Load Connected to “+”)

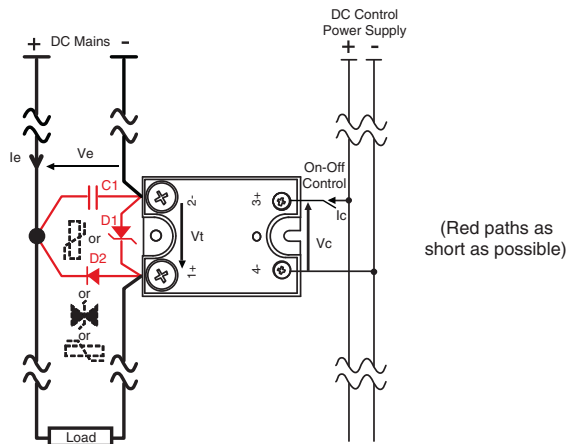

Figure 5

TIME DIAGRAMS

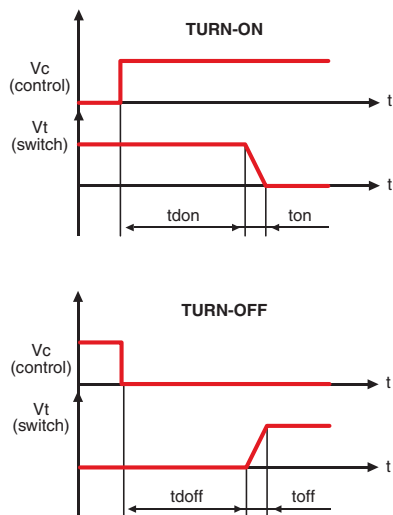

Figure 6

ON RESISTANCE VS. TEMPERATURE

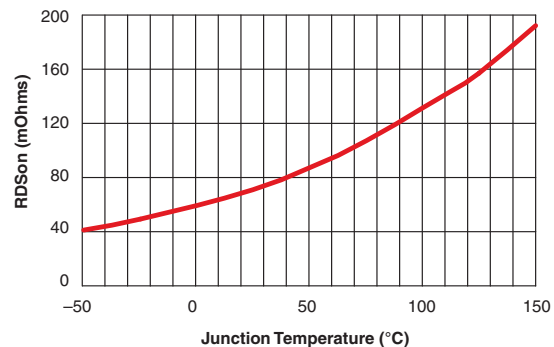

Figure 7

POWER DISSIPATION AND LOAD CURRENT LIMIT VS. TEMPERATURE

Please refer to the installation notice for precautions about mounting the device on a heat sink.

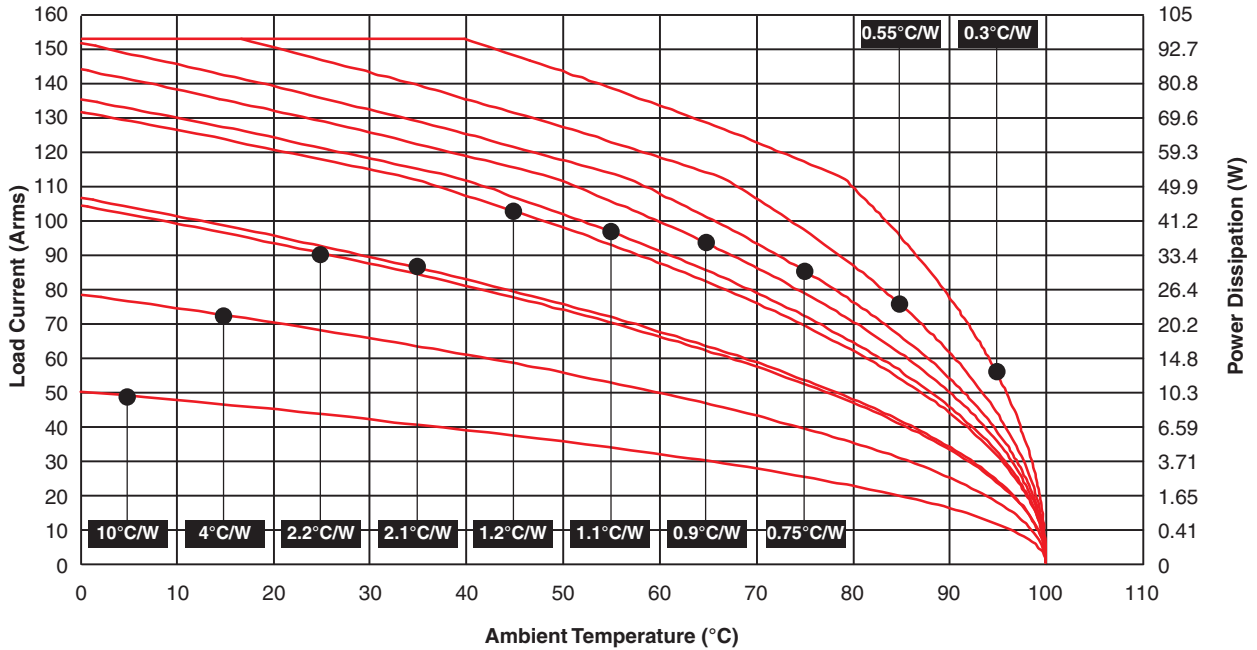

Figure 8

GENERAL SPECIFICATIONS

(+25°C ambient temperature unless otherwise specified)

ENVIRONMENTAL SPECIFICATIONS

	Min	Max	Units
Operating Temperature	-40	+90	°C
Storage Temperature	-40	+100	°C
Input-Output Isolation	4000		Vrms
Insulation Capacitance	8		pF
Junction Temperature		150	°C

CONNECTIONS

	Power	Control
Screwdriver	Phillips NR2	Phillips NR1
Tightening Torque	1.8 N.m	0.8 N.m
Insulated crimp terminals (Round Tabs, Eyelet Type)	M5	M3

MISCELLANEOUS

Display	Green LED (ON)
Housing	UL94V0
Mounting	2 screws (M4x12mm)
Noise Level	No audible noise

GENERAL

Standards	IEC60947-1
Protection Level	IP00
Protection Against Direct Touch	None
CE Marking	Yes
UL, cULUS & VDE Approvals	Pending

E.M.C. EMISSION

Radiated & Conducted Disturbances NFEN55011

PROTECTIVE COVER AVAILABLE
Add -14 to part number

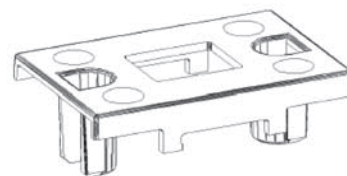

Figure 9

NOTES

1. For additional/custom options, contact factory.